

### 1. Introduction

AH402F Hall-Effect bipolar sensor, employed with high voltage bipolar technology, has been designed purposely for automotive and industrial applications, and operates with supply voltages from 3.8 V to 60 V in temperature range from -40 °C up to 150 °C. AH402F is available in SMD-package SOT23 and in the leaded version T092S.

### 2. Features

- Operates from 3.8 V to 60 V supply voltage
- Overvoltage protection capability up to 80 V
- Highest ESD performance up to  $\pm 4\text{kV}$
- Short-circuit protected open-drain output
- Wide temperature range from -40 °C to 150 °C
- Ideal sensor for applications in extreme automotive and industrial environments
- Tiny SOT23 package and T092S package

### 3. Potential Applications

- Brushless DC motor commutation
- Speed measurement
- Revolution counting
- Angular position detection
- Proximity detection

### 4. Block Diagram

The circuit includes temperature compensated voltage regular, Hall plate, signal amplifier and hysteresis comparator in single silicon chip. The regulated voltage provides the reference voltage for the hall plate. A magnetic field perpendicular to the sensor surface generates a hall voltage, which is amplified and then sent to a hysteresis comparator.

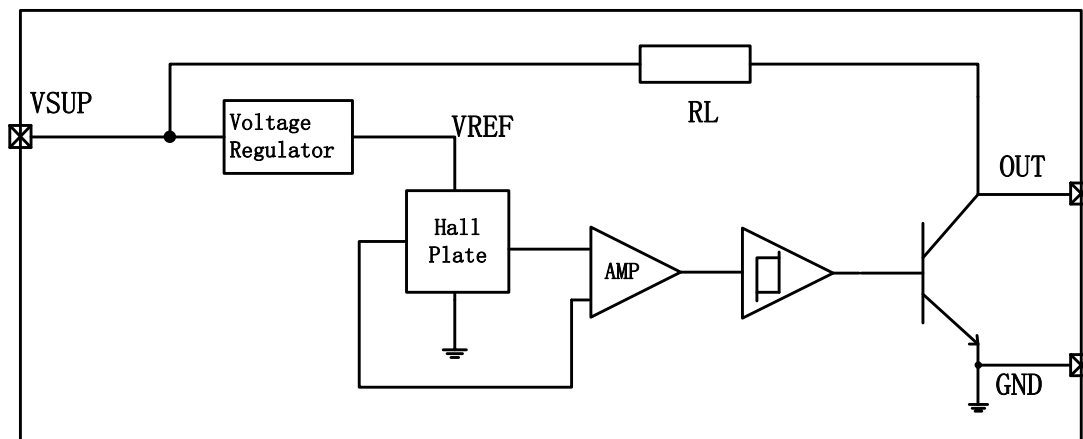

# AH402F

High Voltage Hall Effect Switch

Vinbelltech Limited

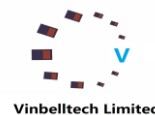

## 5. Pin Description

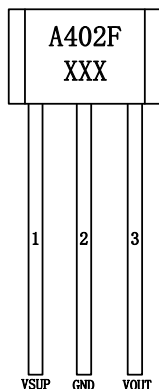

TO92S

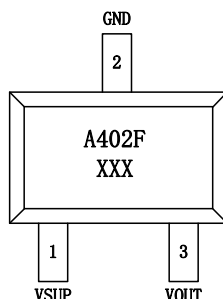

SOT23

## 6. Ordering information

Partnumber	package	Packing	Ambient, T <sub>A</sub>
AH402FUA	TO92S	Bulk, 1000 pieces/bag	-40°C to 150°C
AH402FSU	SOT23	Reel, 3000pieces/reel	-40°C to 150°C

## 7. Pin assignment

SOT23-3LPin number	TO92SPin number	Name	Function
1	1	VSUP	Power supply
2	2	GND	Ground
3	3	VOUT	Open collector with a internal pull-up resistor

## 8. Absolute Maximum Ratings

Parameters	Symbol	Min	Max	Units
Power supply Voltage	VSUP	-0.5	80	V
Output voltage	VOUT	-0.5	80	V
Output current sink	Isink	0	40	mA
Operating ambient temperature	T <sub>a</sub>	-40	150	°C
Storage temperature	T <sub>stg</sub>	-50	165	°C

### 9. Electrical and magnetic characteristics(Ta=25°C)

Symbol	Parameter	Test conditions	Min.	Typ.	Max.	Units
Electrical characteristics						
VSUP	Supply voltage		3.8		60	V
ISUP	Supply current			4.8	8	mA
Ile	Leakage current	Off state			10	uA
Vsat	Output saturation voltage	On state			0.4	V
Tr	Output rise time	Rload=1kohms Cload=20pF			1	uS
Tf	Output fall time	Rload=1kohms Cload=20pF			1.5	uS
RL	Built-in pull-up resistor			10		Kohm
Magnetic characteristics						
Bop	Operate point	Rload=1kohms Cload=20pF	10	25	40	Gauss
Brp	Release point		-40	-25	-10	Gauss
Bhys	Hysteresis			50		Gauss

### 11. Application Circuit

Typical application circuit (see Fig. below)

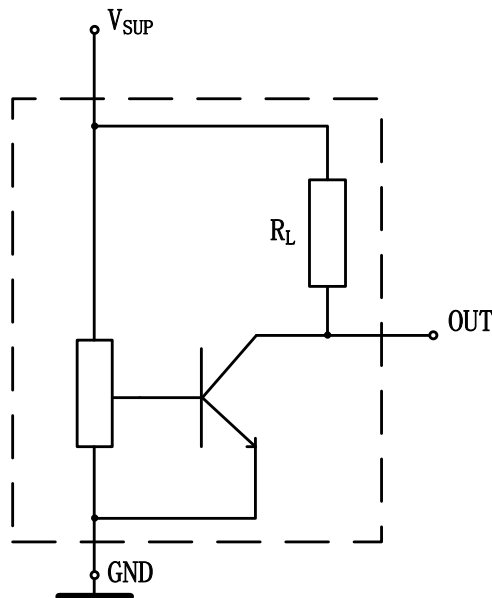

An example of typical application circuit

For applications with disturbances on the supply line or radiated disturbances, a series resistor RV and two capacitors CP and CL all placed close to the sensor are recommended (see Fig. below).

For example: RV =100 ohms, CP = 4.7 nF, and CL = 1 nF.

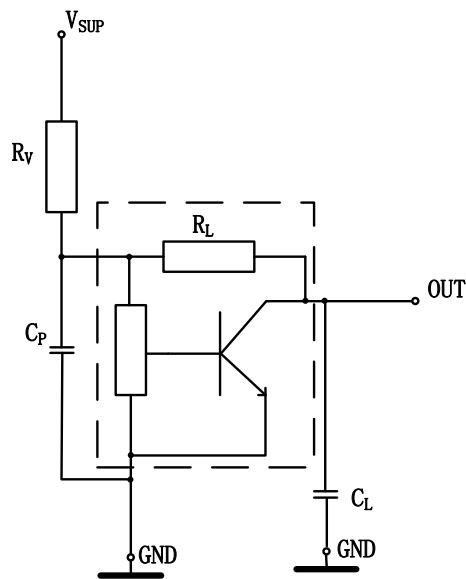

Example of application circuit 2

## 12. Outline dimensions

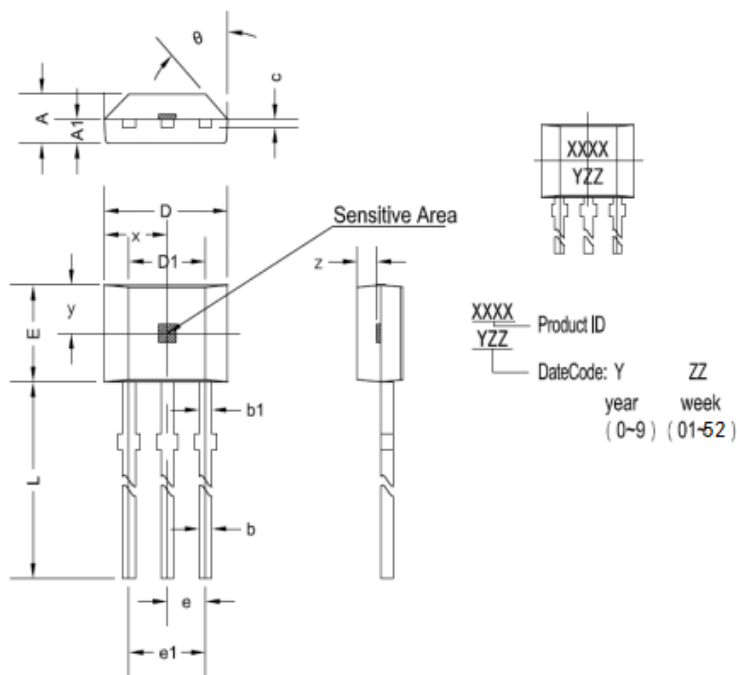

# AH402F

## High Voltage Hall Effect Switch

Vinbelltech Limited

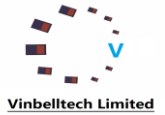

### AH402FUA package outline

symbol	Size (mm)		Size (in inches)	
	minimum	maximum	minimum	maximum
A	1.42	1.67	0.056	0.066
A1	0.66	0.86	0.026	0.034
b	0.35	0.56	0.014	0.022
b1	0.4	0.55	0.016	0.022
C	0.36	0.51	0.014	0.02
D	3.9	4.2	0.154	0.165
D1	2.97	3.27	0.117	0.129
E	2.9	3.28	0.114	0.129
e	1.270 TYP		0.050 TYP	
e1	2.44	2.64	0.096	0.104
L	13.5	15.5	0.531	0.61
x	2.025TYP		0.080TYP	
y	1.545TYP		0.061TYP	
z	0.500TYP		0.020TYP	
$\theta$	45°TYP		45°TYP	

### AH402FSU package outline

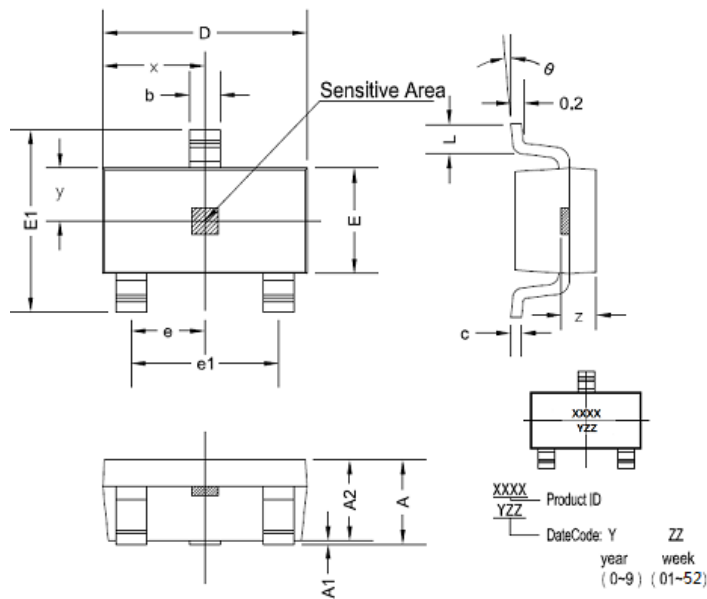

symbol	Size (mm)		Size (inches)	
	Min.	Max.	Min.	Max.
A	1.05	1.25	0.041	0.049
A1	0	0.1	0	0.004
A2	1.05	1.15	0.041	0.045
b	0.3	0.5	0.012	0.02
c	0.100	0.2	0.004	0.008
D	2.82	3.02	0.111	0.119
E	1.5	1.7	0.059	0.067
E1	2.65	2.95	0.104	0.116
e	0.950 TYP		0.037 TYP	
e1	1.8	2	0.071	0.079
L	0.3	0.6	0.012	0.024
x	1.460TYP		0.057TYP	
y	0.800TYP		0.032TYP	
z	0.600TYP		0.024TYP	
$\theta$	0°	8°	0°	8°

Copyright ©2018, Vinbelltech Limited

Vinbelltech Limited reserves the right to make, from time to time, such departures from the detail specifications as may be required to permit improvements in the performance, reliability, or manufacturability of its products. Before placing an order, the user is cautioned to verify that the information being relied upon is current.

Vinbelltech Limited products are not to be used in any devices or systems, including but not limited to life support devices or systems, in which a failure of Vinbelltech Limited product can reasonably be expected to cause bodily harm.

The information included herein is believed to be accurate and reliable. However, Vinbelltech Limited assumes no responsibility for its use; nor for any infringement of patents or other rights of third parties which may result from its use.