

AC / DC Sensing Current Sensor with Digital Data output**Feature:**

- Small package with digital current output
- Operating voltage DC5.0V
- Temperature compensation
- Diameter 9.0mm conductor through hole
- Sensing current range:
AC: 0~50A (50Hz, 60Hz)
DC: 0~±75A
- High accuracy:
AC: (0~24A) ± 0.48A
(24~50A) ± 2%
- DC: ±(0~24A) ± 0.48A
±(24~75A) ± 2%
- Resolution: 222mA
- UART digital data output · Baud Rate : 9600 bps
- Isolation voltage 4KV
- Application Note: <http://www.winson.com.tw/Product/83>

**General Description:**

DWCS1600 is a AC/DC current sensor with calibrated digital signal output. It applies exclusive digital signal collecting technique and allows for easy implementation without breaking original system. Typical applications include load detection and management, over-current fault detection and any intelligent power management system etc...

The DWCS1600 consists of a precise, low-temperature drift linear hall sensor IC with temperature compensation circuit, temperature sensor, digital signal processor and through-hole mechanism with a diameter of 9.0mm etc.

All the sensors on DWCS1600 are temperature compensated and calibrated with accurate calibration instrument. The UART interface directly transmits digital current signals, making system integration simple and fast. Small size, low consumption and the terminals of the conductive path are electrically isolated from the sensor leads enable DWCS1600 to be suited in all kinds of harsh application occasions.

Winson reserves the right to make changes to improve reliability or manufacturability.

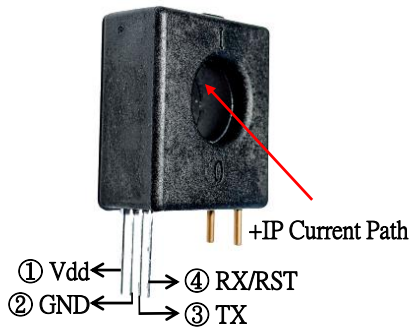

Absolute Maximum Range

Supply Voltage, Vdd	----- 6V
Pass Through Wire Diameter	----- 9.0mm
Basic Isolation Voltage	----- 4000V
Operating Temperature Range, Ta	----- -40°C to +105°C
Storage Temperature Range, Ts	----- -60°C to +125°C

Note: Stresses above those listed may cause permanent damage to the devices

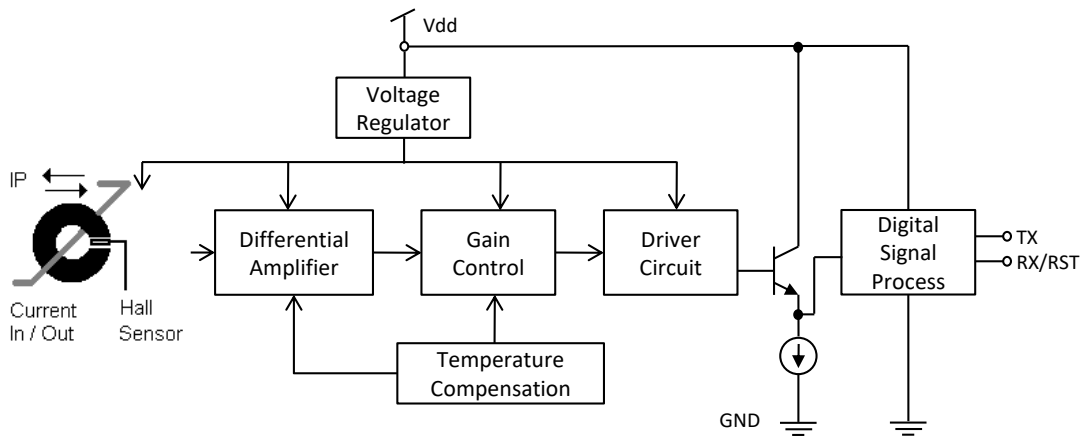

Functional Block Diagram

Selection Guide:

Model	Maximum Current		Operating Voltage	Frequency	Mode
	AC	DC			
DWCS1600-AC50C	50A	-	5.0V	50Hz/60Hz	Continuous
DWCS1600-DC50C	-	75A	5.0V	DC	Continuous
DWCS1600-50C	50A	75A	5.0V	50Hz/60Hz,DC	Professional (AT+Command)

Note:

Continuous Mode: UART Interface, continuous transmission, external reset method (RST pull low to GND).

Professional Mode: UART interface, command transmission, internal reset method (RX received command).

Pad Description:

Pad No	Pad Name	I/O	Description
1	VDD	-	The positive power input pin
2	GND	-	The system ground

Winson reserves the right to make changes to improve reliability or manufacturability.

3	TX	O	The current data output, UART interface, baud rate 9600 bits/sec
4	RX/RST	I	RST(Continuous): External Reset, RX(Professional): Internal UART Reset

Electrical Characteristics: Common Operating Characteristics

Symbol	Parameter	Test Condition	Min.	Typ.	Max.	Unit
V _{DD}	Operation Voltage	-	4.9	5	5.1	V
I _{DD}	Operation Current	V _{DD} = 5.000V	-	6	12	mA
-	Conductor Through Hole	-	-	9	-	mm ²
T _{OP}	Operating Temperature	-	-20	-	70	°C
A _{CC}	Internal Temperature Accuracy	V _{DD} = 5.000V	-	-	5	°C

-AC50C

V_{DD} = 5.000V

Symbol	Parameter	Test Condition	Min.	Typ.	Max.	Unit
I _{OP}	Current Range	-	0	-	50	A
E _{TOT}	Current Output Error	I _{OP} = 0~24A, T _{op} = 25 °C	-	±0.48	-	A
		I _{OP} = 24~50A, T _{op} = 25 °C	-	±2	-	%
		I _{OP} = 0~50A, -20 °C < T _{op} < 70 °C	-	±5	-	%

-DC50C

V_{DD} = 5.000V

Symbol	Parameter	Test Condition	Min.	Typ.	Max.	Unit
I _{OP}	Current Range	-	0	-	75	A
E _{TOT}	Current Output Error	I _{OP} =0~24A, T _{op} = 25 °C	-	±0.48	-	A
		I _{OP} =24~75A, T _{op} = 25 °C	-	±2	-	%
		I _{OP} =0~75A, -20 °C < T _{op} < 70 °C	-	±5	-	%

Winson reserves the right to make changes to improve reliability or manufacturability.

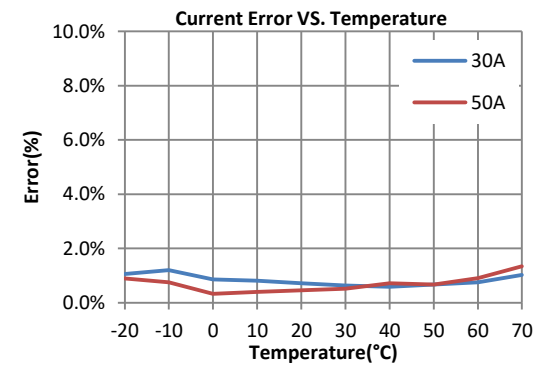
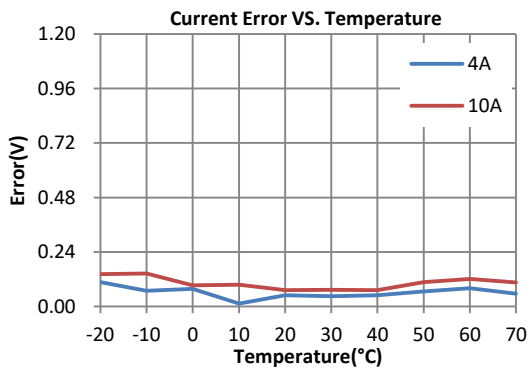
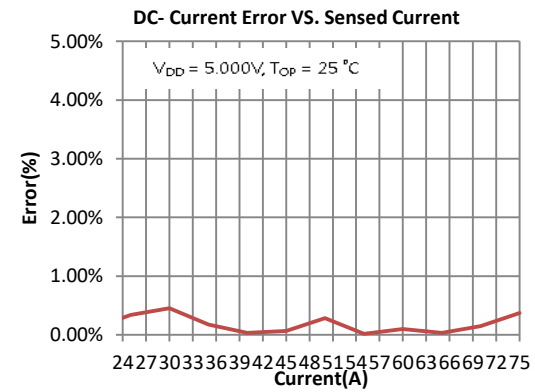
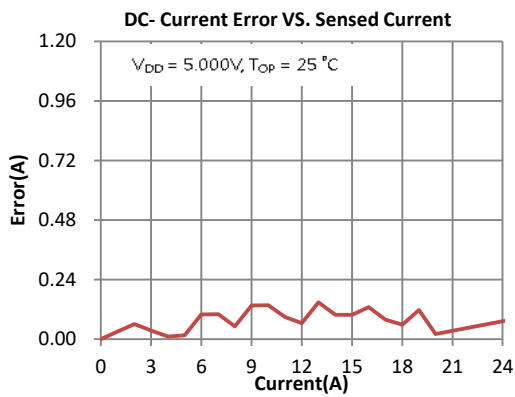
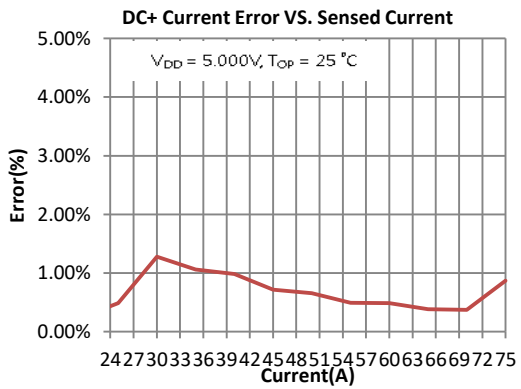
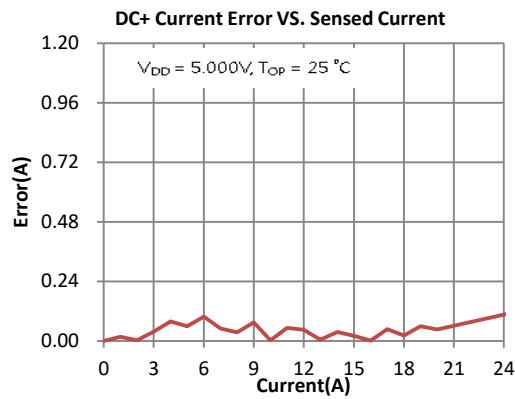
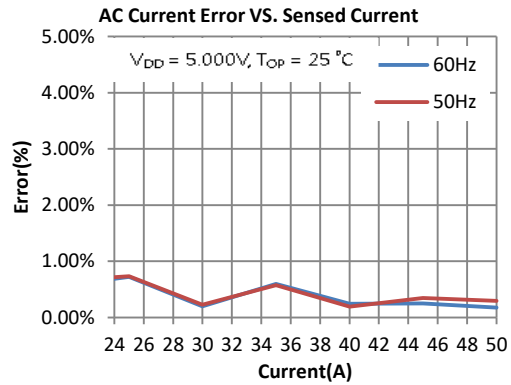
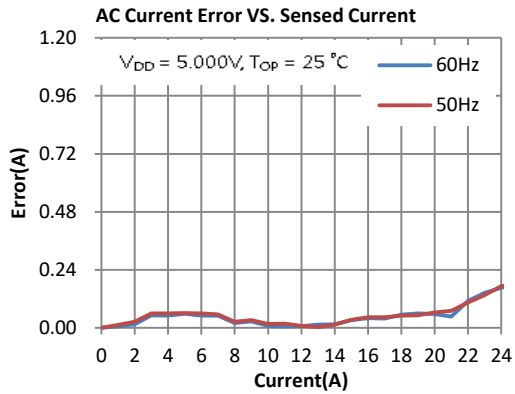

Winson reserves the right to make changes to improve reliability or manufacturability.

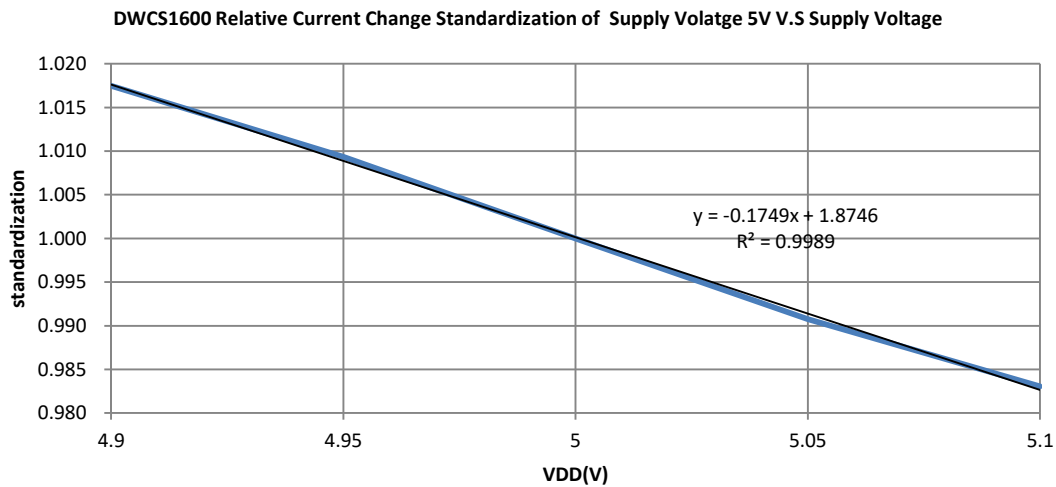

Application Note:

(1) Operating Mode:

(1.1) Continuous mode: Continuously transmit current data. Reset need to pull low the RST pin to GND.

(1.2) Professional mode: Measure current data and reset according to the command, RX received command and please refer to the commands_{< Table}

1>.

(2) Measurement Method:

(2.1) AC measurement: After power-on, the sensor will automatically reset the current value when no current passes through the sensor and the current value can be also manually reset to zero. Data update rate is 2 Data /sec.

(2.2) DC measurement: After power-on, the current value must be manually reset to zero when no current passes through the sensor. Data update rate is 10 Data /sec.

(2.3) When measuring DC current, the sensor will generate an amount of remanence. If this remanence cause reading error, please re-reset it.

(2.4) The proper use of reset function will make the measurement more accurate.

(3) Measured Current Data Output:

The measured current can be transmitted by UART format.

(3.1) If the measured data is AC “1.23”A, then the output data is ‘~’, ‘1’, ‘.’, ‘2’, ‘3’, ‘0’, ‘\r’, ‘\n’, total of 8 bytes; the output data is ASCII code. If the measured data is “10.45” A, then the output data is ‘~’, ‘1’, ‘0’, ‘.’, ‘4’, ‘5’, ‘\r’, ‘\n’, total of 8 bytes.

(3.2) If the measured data is +DC “1.23”A, then the output data is ‘+’, ‘1’, ‘.’, ‘2’, ‘3’, ‘0’, ‘\r’, ‘\n’, total of 8 bytes; the output data is ASCII code.

(3.3) If the measured data is -DC “1.23”A, then the output data is ‘-’, ‘1’, ‘.’, ‘2’, ‘3’, ‘0’, ‘\r’, ‘\n’, total of 8 bytes; the output data is ASCII code.

Winson reserves the right to make changes to improve reliability or manufacturability.

(4) Measured Current Data Output:

In order to calculate true RMS of AC current, you need to know “zero” value of AC current first. The “zero” value of symmetric AC current is the average value $V_o(dc)$ of the current shown in Figure 1.

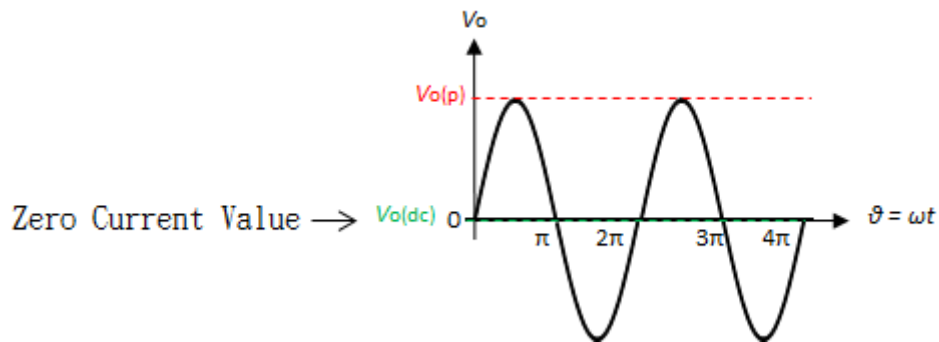

Figure 1 The zero current value of sine waveform

But in asymmetrical AC current, the “zero” value is not the average value $V_o(dc)$ of the current. Based on this “zero” value and do RMS calculation. You will get wrong answer.

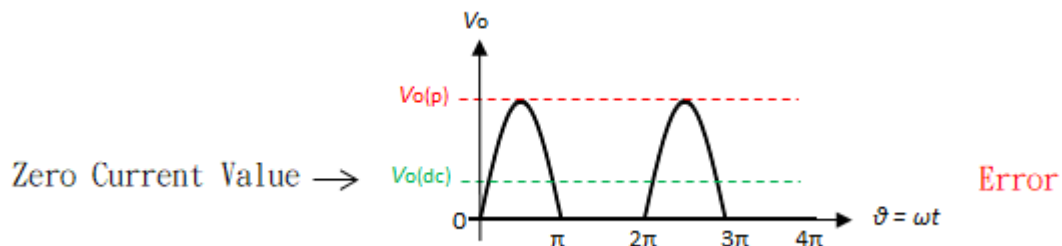

Figure 2 The zero current value of the asymmetric waveform (Error)

The DWCS1600 offers a true RMS solution for both symmetric and asymmetric AC current. It can correctly detect “zero” current value, shown in Figure 3. and do perfect RMS calculation.

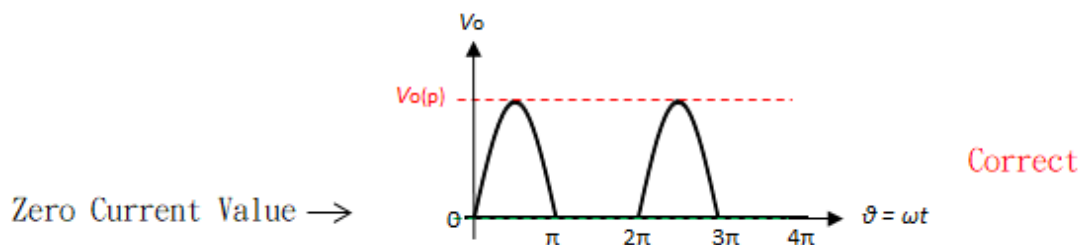
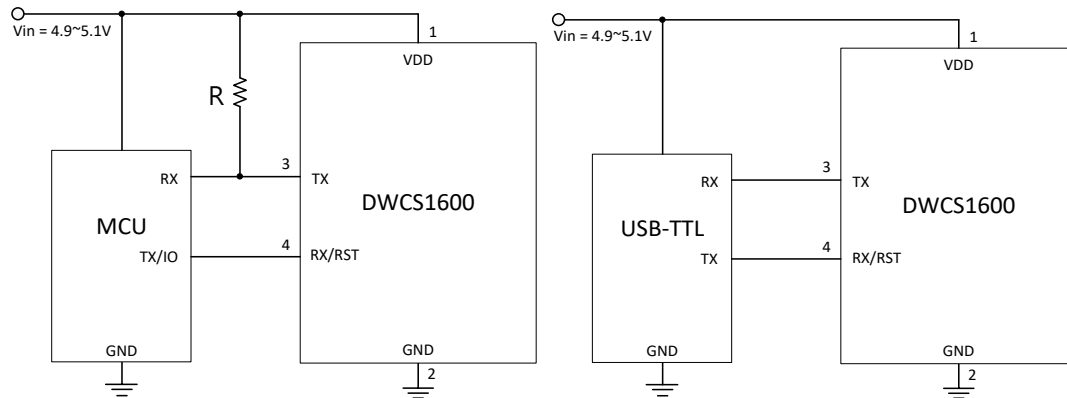

Figure 3 The zero current value of the asymmetric waveform (Correct)

(5) Application Diagram:



App. 1 Connect to MCU

App. 2. Connect to USB-TTL

(DWCS1600 TX needs open drain with external pullup resistors)

Package: (Units: mm)

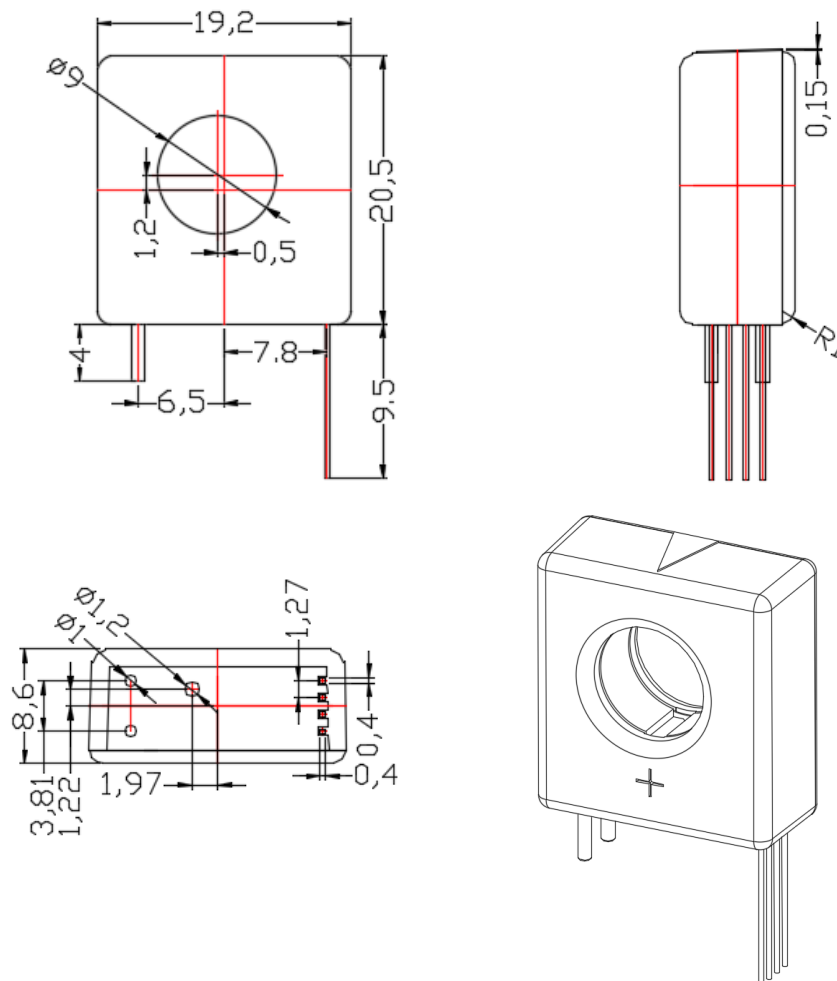

Winson reserves the right to make changes to improve reliability or manufacturability.

Table 1

Setting Command	Command	Example	Return Parameter
Reset Current	AT+RST\r\n	"AT+RST\r\n"	"OK\r\n" ⁽¹⁾
0: DC 1: AC ⁽²⁾	AT+CURRE\r\n	"AT+CURRE,0\r\n" "AT+CURRE,1\r\n"	"OK\r\n" ⁽¹⁾
Measure Current ⁽²⁾	AT+MEAS\r\n	"AT+MEAS\r\n"	<Current>
Measure Temperature ⁽²⁾	AT+TEMP\r\n	"AT+TEMP\r\n"	<Temperature>

1. Command is error: return "Err\r\n" °
2. It is only applicable to the professional version, and it is prohibited to use it in continuous mode.