

# Fixed Frequency Current Mode PWM Controller

**IL3843**

## DESCRIPTION

Fixed frequency current-mode PWM controller. It is specially designed for Off Line And DC-to-DC converter applications with minimal external component. This integrated circuit features a trimmed oscillator for precise duty cycle control, a temperature compensated reference, high gain error amplifier, current sensing comparator, and a high current totempole output ideally suited for driving a power MOSFET.

Protection circuitry includes built in under-voltage lockout and current limiting.

## FEATURES

- ◆ Automatic Feed Forward Compensation
- ◆ High Gain Totem Pole Output
- ◆ Internally Trimmed Bandgap Reference
- ◆ Undervoltage Lockout with Hysteresis
- ◆ Low Start Up Current
- ◆ Optimized for offline converter
- ◆ Double pulse suppression
- ◆ Current mode operation to 500KHz

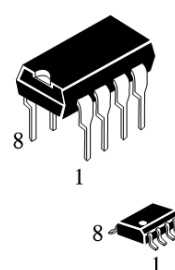

**N SUFFIX  
DIP**

**D SUFFIX  
SOP**

**ORDERING INFORMATION**  
 IL3843N DIP  
 IL3843D SOP  
 $T_A = 0^\circ \text{ to } 70^\circ \text{ C}$  for all packages.

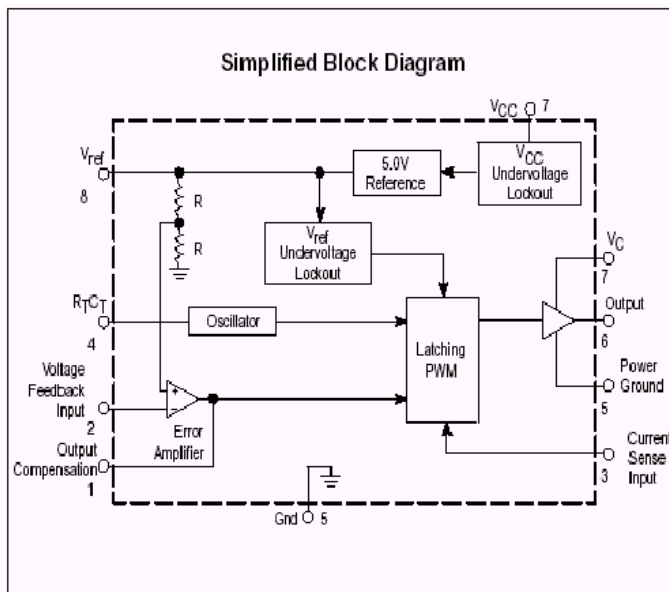
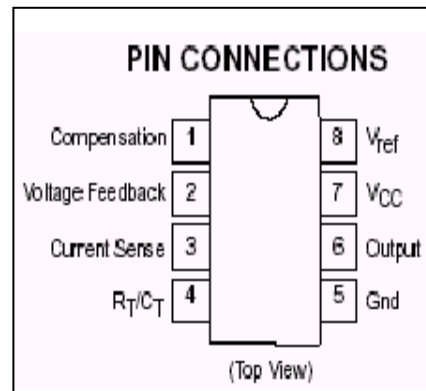

## ORDERING INFORMATION

Device	Operating Temperature Range	Package
IL3843N	T <sub>A</sub> =0° to +70°C	DIP-8
IL3843D	T <sub>A</sub> =0° to +70°C	SOP-8

**PIN FUNCTION DESCRIPTION**

Pin No.	Function	Description
1	Compensation	This pin is the Error Amplifier output and is made available for loop compensation
2	Voltage Feedback	This is the inverting input of the Error Amplifier. It is normally connected to the switching power supply output through a resistor divider.
3	Current Sense	A voltage proportional to inductor current is connected to this input. The PWM uses this information to terminate the output switch conduction
4	RT/CT	The Oscillator frequency and maximum Output duty cycle are programmed by connecting resistor $R_T$ to $V_{REF}$ and capacitor $C_T$ to ground. Operation to 500kHz is possible.
5	GND	This pin is the combined control circuitry and power ground
6	Output	This output directly drives the gate of a power MOSFET. Peak currents up to 1.0A are sourced and sunk by this pin.
7	Vcc	This pin is the positive supply of the control IC.
8	$V_{REF}$	This is the reference output. It provides charging current for capacitor $C_T$ through resistor $R_T$

**ABSOLUTE MAXIMUM RATINGS**

Characteristic	Symbol	Value	Unit
Total Power Supply and Zener Current	$(I_{CC} + I_Z)$	30	mA
Output Current	$I_O$	$\pm 1.0$	A
Output Energy (Capacitive Load per Cycle)	W	5.0	$\mu J$
Error Amp Output Sink Current	$I_{OE}$	10	mA
Current Sense and Voltage Feedback Inputs	$V_{in}$	-0.3 to 5.5	V
Maximum Power Dissipation @ $T_A = 25^\circ C$ :			
DIP-8	$P_D$	0.862	W
SOP-8		0.625	
Thermal Resistance, Junction-to-Air	$R_{\theta JA}$	145	$^\circ C/W$
Operating Junction Temperature	$T_J$	+150	$^\circ C$
Storage Temperature Range	$T_{stg}$	-65 ~ +150	$^\circ C$

\* Stresses beyond those listed under "absolute maximum ratings" may cause permanent damage to the device. These are stress ratings only and functional operation of the device at these or any other conditions beyond those indicated under "recommended operating conditions" is not implied. Exposure to absolute-maximum-rated conditions for extended periods may affect device reliability.

**ELECTRICAL CHARACTERISTICS** (V<sub>CC</sub>=15V unless otherwise noted)

Characteristics	Symbol	Min	Max	Unit
<b>REFERENCE SECTION</b>				
Reference Output Voltage (I <sub>O</sub> =1.0mA, V <sub>CC</sub> =15V, T <sub>A</sub> =25±10°C) (I <sub>O</sub> =1.0mA, V <sub>CC</sub> =15V, T <sub>A</sub> =Tlow to Thigh)	V <sub>ref</sub>	4.9 4.865	5.1 5.135	V
Line Regulation (V <sub>CC</sub> =12V to 25V, T <sub>A</sub> =Tlow to Thigh)	Reg <sub>line</sub>		20	mV
Load Regulation (I <sub>O</sub> =1.0 to 20mA, T <sub>A</sub> =Tlow to Thigh)	Reg <sub>load</sub>		25	mV
Total Output Variation over Line, Load, Temperature (Note1) (V <sub>CC</sub> =12V, I <sub>O</sub> =1.0mA, T <sub>A</sub> =Tlow to Thigh) (V <sub>CC</sub> =25V, I <sub>O</sub> =20mA, T <sub>A</sub> =Tlow to Thigh)	V <sub>final</sub>	4.82	5.18	V
Output Short Circuit Current (V <sub>CC</sub> =15V)	I <sub>SC</sub>	-30	-180	mA
<b>OSCILLATOR SECTION</b>				
Frequency (V <sub>CC</sub> =15V, T <sub>j</sub> =25°C, R <sub>T</sub> =10k, C <sub>T</sub> =3.3nF) (V <sub>CC</sub> =15V, T <sub>A</sub> =Tlow to Thigh, R <sub>T</sub> =10k, C <sub>T</sub> =3.3nF)	f <sub>osc</sub>	47 46	57 60	kHz
Frequency Change with Voltage (V <sub>CC</sub> =12V to 25V, T <sub>A</sub> =Tlow to Thigh, R <sub>T</sub> =10k, C <sub>T</sub> =3.3nF)	Δf <sub>osc</sub> /ΔV		1.0	%
Discharge Current (V <sub>osc</sub> =2.0V, V <sub>CC</sub> =15V) T <sub>j</sub> =25°C T <sub>A</sub> =Tlow to Thigh	I <sub>disch</sub>	7.5 7.2	9.3 9.5	mA
<b>ERROR AMPLIFIER SECTION</b>				
Voltage Feedback Input (V <sub>O</sub> =2.5V, V <sub>CC</sub> =15V, T <sub>A</sub> =Tlow to Thigh)	V <sub>FB</sub>	2.42	2.58	V
Input Bias Current (V <sub>FB</sub> =2.7V, V <sub>CC</sub> =15V, T <sub>A</sub> =Tlow to Thigh)	I <sub>IB</sub>		-2.0	μA
Open Loop Voltage Gain (V <sub>O</sub> =2.0V to 4.0V, V <sub>CC</sub> =15V, T <sub>A</sub> =Tlow to Thigh)	A <sub>VOL</sub>	65		dB
Unity Gain Bandwidth (V <sub>CC</sub> =15V, T <sub>A</sub> =Tlow to Thigh)	BW	0.7		MHz
Power Supply Rejection Ratio (V <sub>CC</sub> =12V to 25V, V <sub>O</sub> =3.0V, T <sub>A</sub> =Tlow to Thigh)	PSRR	60		dB
Output Current Sink (V <sub>O</sub> =1.1V, V <sub>FB</sub> =2.7V, V <sub>CC</sub> =15V, T <sub>A</sub> =Tlow to Thigh) Source (V <sub>O</sub> =5.0V, V <sub>FB</sub> =2.3V, V <sub>CC</sub> =15V, T <sub>A</sub> =Tlow to Thigh)	I <sub>Sink</sub> I <sub>Source</sub>	2.0 -0.5		mA
Output Voltage Swing High State (V <sub>FB</sub> =2.3V, V <sub>CC</sub> =15V, R <sub>L(GND)</sub> =15k, T <sub>A</sub> =Tlow to Thigh) Low State (V <sub>FB</sub> =2.7V, V <sub>CC</sub> =15V, R <sub>L(5.0)</sub> =15k, T <sub>A</sub> =Tlow to Thigh)	V <sub>OH</sub> V <sub>OL</sub>	5.0	1.1	V
<b>CURRENT SENSE SECTION</b>				
Current Sense Input Voltage Gain (V <sub>FB</sub> =0V, V <sub>CC</sub> =15V, T <sub>A</sub> =Tlow to Thigh)	A <sub>v</sub>	2.85	3.15	V/V
Maximum Current Sense Input Threshold (V <sub>FB</sub> =0V, V <sub>CC</sub> =15V, T <sub>A</sub> =Tlow to Thigh)	V <sub>th</sub>	0.9	1.1	V
Input Bias Current (V <sub>CC</sub> =15V, T <sub>A</sub> =Tlow to Thigh)	I <sub>IB</sub>		-10	μA
Propagation Delay (Current Sense Input to Output) (V <sub>CC</sub> =15V, T <sub>A</sub> =Tlow to Thigh)	t <sub>PLH</sub>		300	ns

**ELECTRICAL CHARACTERISTICS** (V<sub>CC</sub>=15V unless otherwise noted)

Characteristics	Symbol	Min	Max	Unit
<b>OUTPUT SECTION</b>				
Output Voltage Low State (Sink=20mA, V <sub>CC</sub> =15V) (Sink=200mA, V <sub>CC</sub> =15V) High State (Sink=-20mA, V <sub>CC</sub> =15V) (Sink=-200mA, V <sub>CC</sub> =15V)	V <sub>OL</sub>  V <sub>OH</sub>	  13 12	  0.4 2.2	  V
Output Voltage with UVLO Activated (V <sub>CC</sub> =6.0V, I <sub>Sink</sub> =1.0mA, T <sub>A</sub> =T <sub>low</sub> to T <sub>high</sub> )	V <sub>OL(UVLO)</sub>		1.1	V
Output Voltage Rise Time (C <sub>L</sub> =1.0nF, V <sub>CC</sub> =15V, T <sub>A</sub> =T <sub>low</sub> to T <sub>high</sub> )	tr		150	ns
Output Voltage Fall Time (C <sub>L</sub> =1.0nF, V <sub>CC</sub> =15V, T <sub>A</sub> =T <sub>low</sub> to T <sub>high</sub> )	tf		150	ns
<b>UNDERVOLTAGE LOCKOUT SECTION</b>				
Startup Threshold (V <sub>CC</sub> =0V to 15V, T <sub>A</sub> =T <sub>low</sub> to T <sub>high</sub> )	V <sub>th</sub>	7.8	9.0	V
Minimum Operating Voltage After Turn-On (V <sub>CC</sub> =15V to 0V, T <sub>A</sub> =T <sub>low</sub> to T <sub>high</sub> )	V <sub>CC(min)</sub>	7.0	8.2	V
<b>PWM SECTION</b>				
Duty Cycle Maximum (V <sub>CC</sub> =15V, T <sub>A</sub> =T <sub>low</sub> to T <sub>high</sub> , R <sub>T</sub> =10k, C <sub>T</sub> =3.3nF) Minimum (V <sub>CC</sub> =15V, T <sub>A</sub> =T <sub>low</sub> to T <sub>high</sub> , R <sub>T</sub> =10k, C <sub>T</sub> =3.3nF)	DC <sub>max</sub> DC <sub>min</sub>	94	0	%
<b>TOTAL DEVICE</b>				
Power Supply Current Startup: V <sub>CC</sub> =6.5V V <sub>CC</sub> =15V Operating	I <sub>CC</sub>		1.0 17	mA
Power Supply Zener Voltage (I <sub>CC</sub> =25mA, V <sub>CC</sub> =0 to 40V)	V <sub>Z</sub>	30	40	V

**NOTES:** 1.  $V_{final} = V_{ref25} \pm (Reg_{line} + Reg_{load})/1000 \pm |V_{ref70}(V_{ref0}) - V_{ref25}|$   
 $V_{ref25} = V_{ref}$  @ T<sub>A</sub>=25°C;  
 $V_{ref70} = V_{ref}$  @ T<sub>A</sub>=70°C;  
 $V_{ref0} = V_{ref}$  @ T<sub>A</sub>=0°C.

2. T<sub>low</sub>= 0°C ; T<sub>high</sub>=+70°C

**N SUFFIX DIP**  
**(MS – 001BA)**

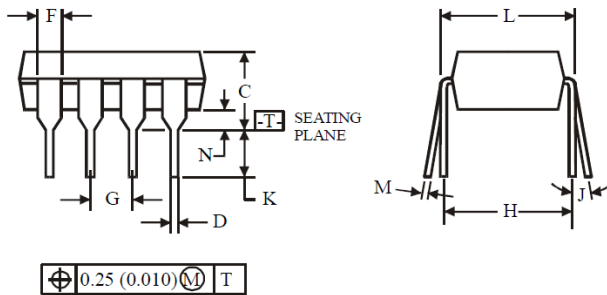
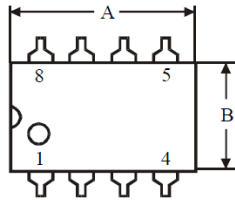
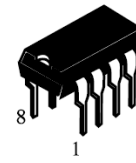

Symbol	Dimension, mm	
	MIN	MAX
A	8.51	10.16
B	6.10	7.11
C		5.33
D	0.36	0.56
F	1.14	1.78
G	2.54	
H	7.62	
J	0°	10°
K	2.92	3.81
L	7.62	8.26
M	0.20	0.36
N	0.38	

**NOTES:**

- Dimensions “A”, “B” do not include mold flash or protrusions.  
Maximum mold flash or protrusions 0.25 mm (0.010) per side.

**D SUFFIX SOP**  
**(MS - 012AA)**

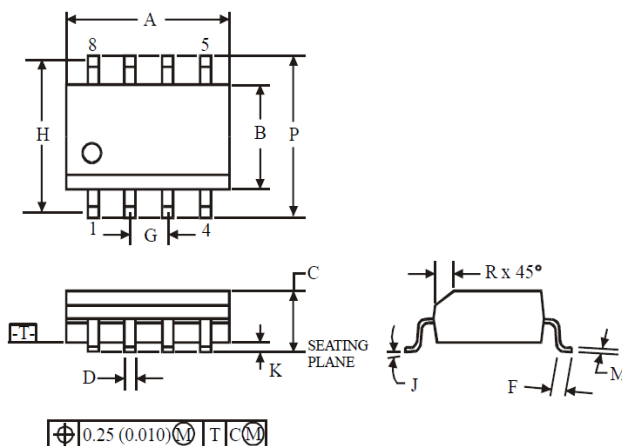

Symbol	Dimension, mm	
	MIN	MAX
A	4.80	5.00
B	3.80	4.00
C	1.35	1.75
D	0.33	0.51
F	0.40	1.27
G	1.27	
H	5.72	
J	0°	8°
K	0.10	0.25
M	0.19	0.25
P	5.80	6.20
R	0.25	0.50

**NOTES:**

- Dimensions A and B do not include mold flash or protrusion.
- Maximum mold flash or protrusion 0.15 mm (0.006) per side for A; for B - 0.25 mm (0.010) per side.