

IC for Electronic Ballasts

ILA3354

Short Description

The bipolar monolithic integrated circuit triggers, monitors and turns-off RF-oscillation of electronic ballast for fluorescent lamps dependent on several control- and monitoring functions.

Features

- Minimum wiring complexity
- Over temperature protection without external components
- Malfunction detection
- Timer output
- Automatical reignition after lamp change

Pinning

Pin 1	TM	temperature mode selection
Pin 2	CT	clock generator
Pin 3	TR	trigger output, turn-off attenuation, oscillation detector
Pin 4	GND	connection to ground
Pin 5	EI	error indication input
Pin 6	LW	input of lamp change
Pin 7	S	switching output of the timer
Pin 8	V _{CC}	supply voltage

Block diagram

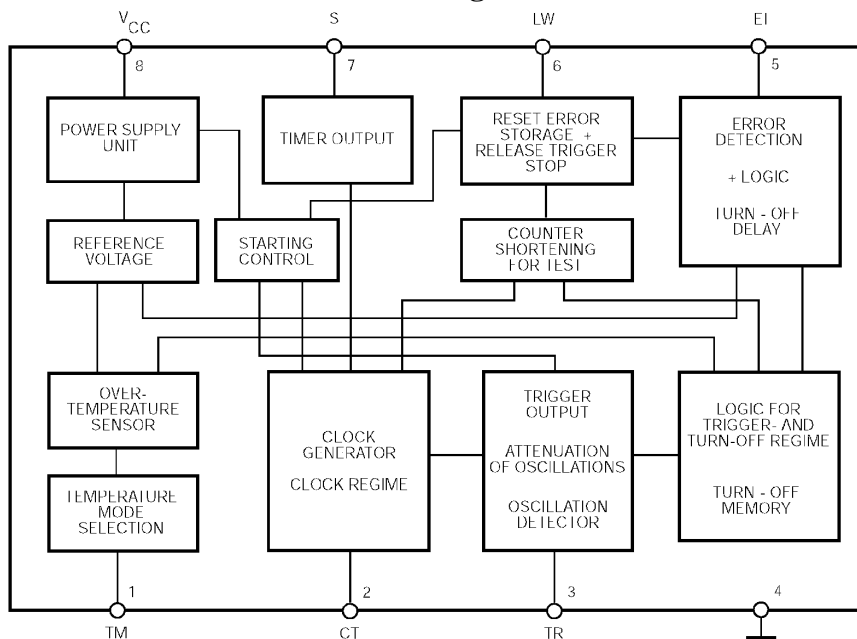

Characteristics of the IC

- The ILA3354 is a control- and monitoring-IC to drive an electronic ballast for fluorescent lamps.
- The IC actuates the oscillation of a self-oscillating circuit for generation of RF-shaped lamp current by means of trigger pulses. After successful excitation the oscillation is monitored and further trigger pulses are blocked.
- The IC has a timer with low-active output which is activated for one second after supply voltage was applied. The switching output is effective for pre-heating and ignition systems.
- The IC consists an error indication input. In case of error indication the IC stops oscillation. Enquiry cycles realize interference reduction.
- After lamp change the IC starts oscillation again.
- The IC protects from over temperature cutting oscillation. It is programmable when the oscillator circuit shall be triggered again.

Functional Description

At the moment of current feeding at terminal V_{CC} , the IC generates the supply voltage via backup capacitor externally connected. As soon as an internal switching threshold of 7 V is reached, trigger pulses are delivered at the output TR with a repetition instalment of 960 μ s. After successful triggering of the oscillator circuit, an oscillation detector guarantees blocking of further trigger pulses. It identifies a stable oscillating process, after a minimum of oscillations is detected per timing.

As soon as a switching threshold of 8 V is reached, all logic units are reset and the timer output S is activated as well. The IC starts a counter, which interrupts the control after one second.

Furthermore, the IC monitors the temperature and the oscillation circuit from a supply voltage of 8 V.

The comparator input EI is useful for error detection. Voltage > 3.75 V, applied at EI, are evaluated as error signals. The error signal is enquired and registered within a cycle repeating every 960 μ s. After registration of the error signal, a counter starts to generate a delay of one second. After this delay time, the voltage at EI is evaluated again. The error storage is set only after a second error, appearing within a directly following evaluation cycle. This error storage is resettable by a short-time power supply disconnection, or with input LW connected via a change of lamp.

The error storing causes the cutting further triggers and the control of the turn-off transistor as well, which turns the output TR to ground. Therefore, the turn-off transistor prevents the control of the oscillator circuit, attenuating it extremely quickly.

Thereby, the current consumption increases by the control of the turn-off transistor. This current amounts more than 5 mA, that the supply voltage across the backup capacitor at pin V_{CC} breaks down (because nominal current feed is less 5 mA). With a switching threshold of 6 V, the control current of the turn-off transistor is switched off, that enables the supply voltage to rise up to the limiting voltage. Because the trigger pulse gate, blocked by the error memory, the oscillation can't start again.

With error storing and attenuation of the oscillation by over temperature it can be defined via selection of the temperature mode, whether the oscillation is automatically triggered after cooling-down of the assembly, or only after mains disconnection.

Absolute Maximum Ratings

Parameter	Pin	Symbol	min	max	Unit
current consumption	V_{CC}	I_{CCeff}		20	mA
peak current for $t < 100 \mu$ s	V_{CC}	I_{CCM}		100	mA
input voltage error indicator	EI	V_{Err}	-0.3	V_{CC}	V
input voltage lamp exchange input	LW	V_{LW}	-0.3	15	V
voltage difference between V_{LW} and V_{CC} for divider factor 16 via LW	LW	$V_{LW} - V_{CC}$		6	V
input current at pin TM	TM	I_{TM}		1	mA
negative current load for $t < 1 \mu$ s with max. repeat frequency = 200kHz	TR	$I_{TR(neg.)}$	-500		mA
switching output current	S	I_S		1	mA
junction temperature		T_J		150	$^{\circ}$ C
storage temperature		T_{stg}	-50	150	$^{\circ}$ C
ambient temperature		T_{amb}	-20	120	$^{\circ}$ C
ESD protection		V_{ESD}		2	kV

* Stresses beyond those listed under "absolute maximum ratings" may cause permanent damage to the device. These are stress ratings only and functional operation of the device at these or any other conditions beyond those indicated under "recommended operating conditions" is not implied. Exposure to absolute-maximum-rated conditions for extended periods may affect device reliability.

Electrical Characteristics

(Tamb = 25 °C, V_{CC} = 10 V, unless specified otherwise)

Parameter	Pin	Symbol	min	typ	max	Unit
range for internal voltage limitation	V _{CC}	V _{lim}	10.8	11.4	12	V
quiescent current consumption	V _{CC}	I _{CC(on)}		1.25	1.5	mA
trigger repeat rate with C _{clock} = 82pF	TR	t _{TRW}	900	1000	1100	μs
output pulse current on 10 Ω	TR	I _{TRM}	400	650	850	mA
output pulse width with 90% amplitude	TR	t _{TR}	0.6	0.9	1.5	μs
saturation voltage of turn-off transistor with I=450 mA	TR	V _{TRsat}		380	500	mV
saturation voltage of switching output	S	V _{Ssat}		0.2	0.45	V
response level of error voltage	EI	K _{OL}	3.60	3.75	3.90	V
switching point of overtemperature turn-off		T _S	95	105	115	°C
switching range to indicate a lamp as removed	LW	V _{LE}			3.25	V
switching range to indicate a lamp as applied	LW	V _{LV}	4.25		V _{CC}	V

Parameter	Condition	Value	Unit
Threshold for connecting the trigger pulses during build-up phase	C _{clock} = 82pF	7	V
Threshold for release of the internal reset	C _{clock} = 82pF	8	V
Threshold for switching-off the control of the turn-off transistor with set error memory	C _{clock} = 82pF	6	V
Delay of response with error detection	C _{clock} = 82pF	1	s
Duration for activation switching output	C _{clock} = 82pF	1	s
Duration needed for rating at least 4 pulse-shaped distortions or a static error signal with twice interrogation within delay time 1 sec	C _{clock} = 82pF	840	μs
Control current of the turn-off transistor	C _{clock} = 82pF	10	mA
Temperature hysteresis for re-ignition after overtemperature switch-off (pin TM is connected to ground)	C _{clock} = 82pF	10	°C

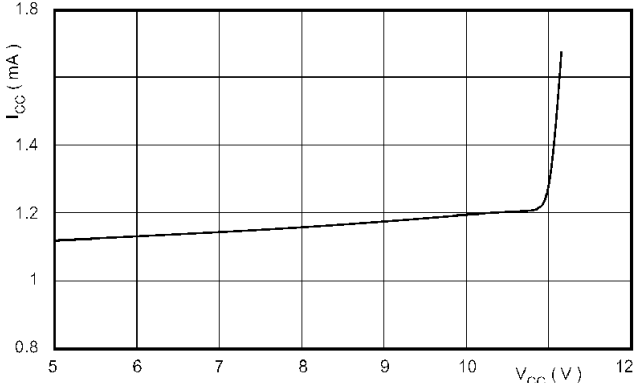

Current consumption vs. supply voltage

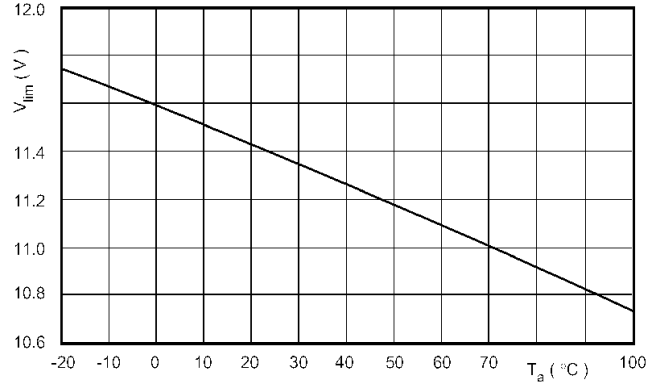

Voltage limiting vs. temperature I_{CC} = 5 mA

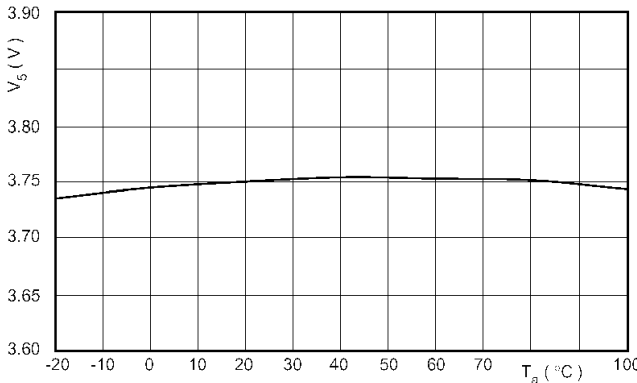

Static overload threshold V_{CC} = 10 V

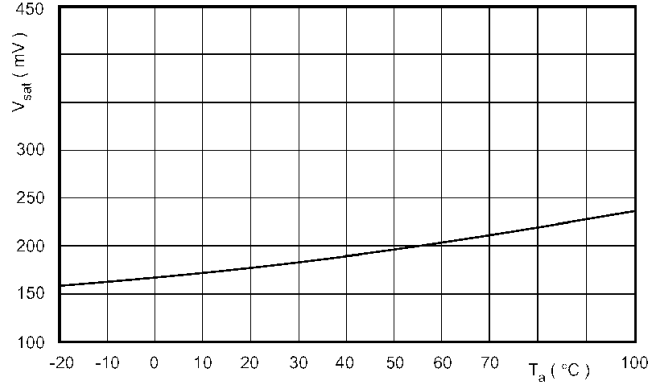

Timer output saturation voltage at 1mA V_{CC} = 10 V

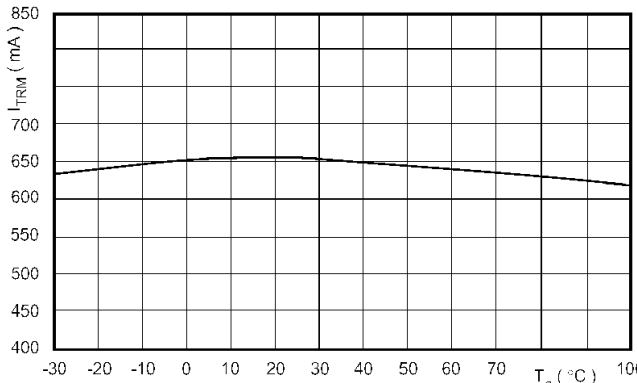

Trigger current at 10 vs. temperature, V_{CC} = 10 V

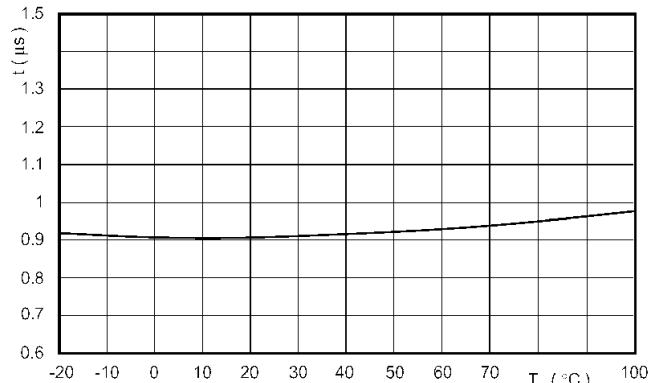

Trigger pulse width (90% amplitude) vs. temperature, V_{CC} = 10 V

Principle Circuit Diagram

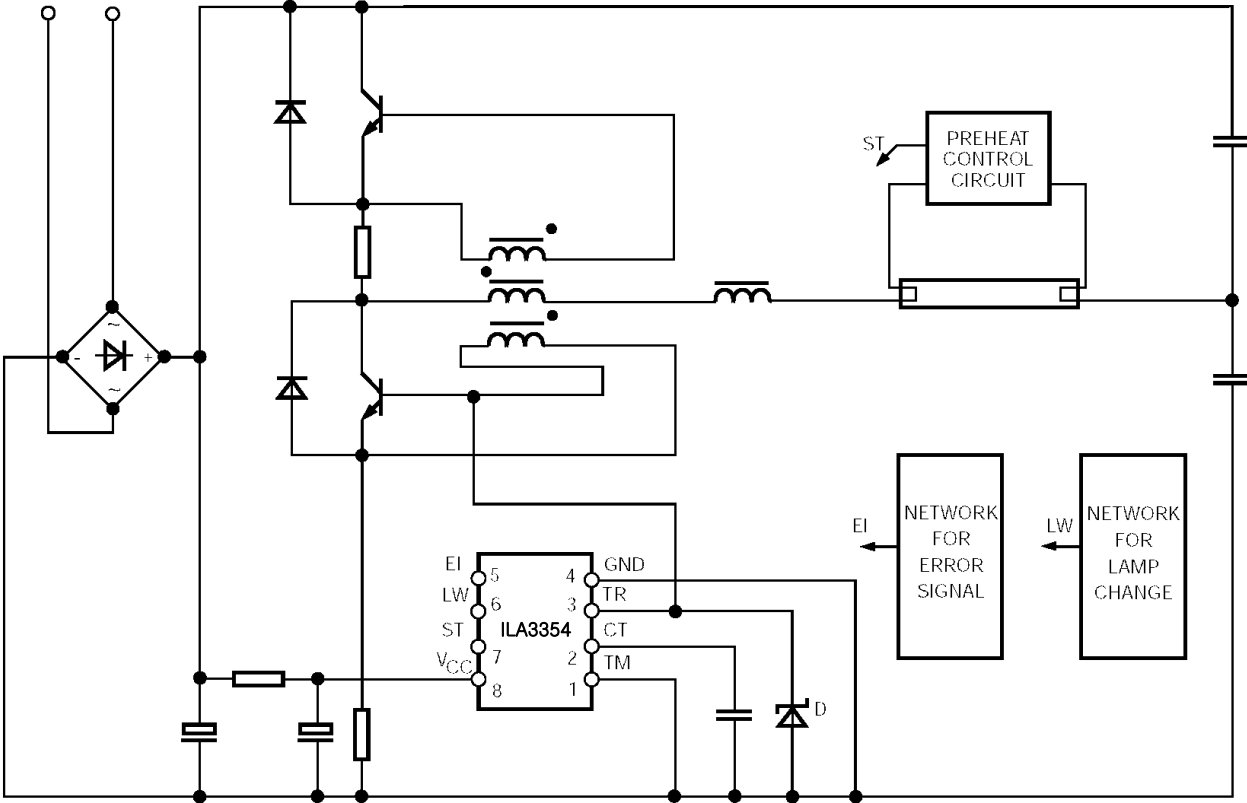

Application Circuit Diagram

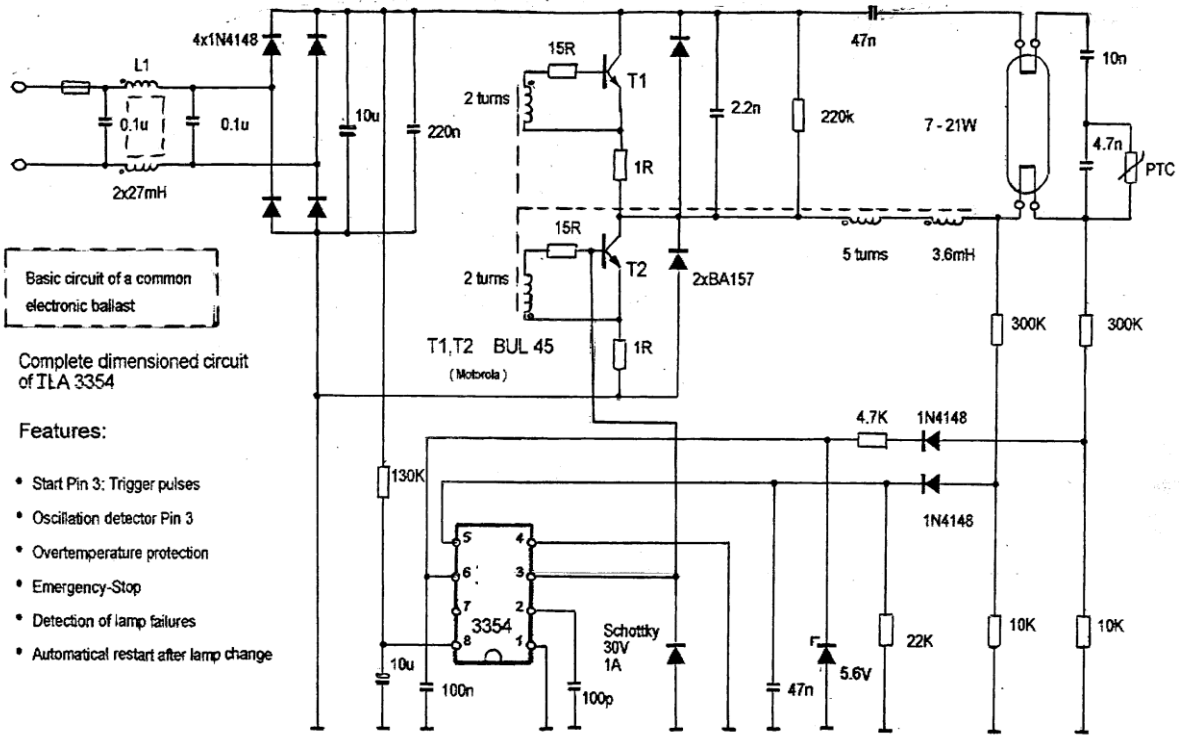

**N SUFFIX DIP
(MS – 001BA)**

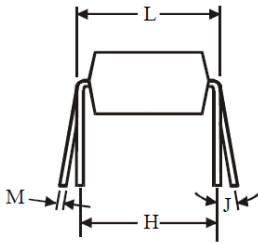
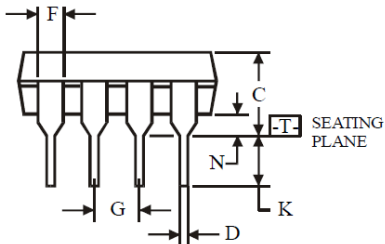
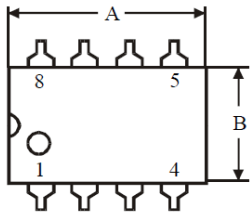
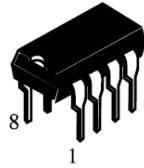

$\text{⌀} 0.25 (0.010) \text{Ⓜ} \text{T}$

Symbol	Dimension, mm	
	MIN	MAX
A	8.51	10.16
B	6.10	7.11
C		5.33
D	0.36	0.56
F	1.14	1.78
G	2.54	
H	7.62	
J	0°	10°
K	2.92	3.81
L	7.62	8.26
M	0.20	0.36
N	0.38	

NOTES:

- Dimensions “A”, “B” do not include mold flash or protrusions.
Maximum mold flash or protrusions 0.25 mm (0.010) per side.