

## Hall Effect Base Linear Current Sensor

### Features:

- Low noise analog signal path
- 85  $\mu\Omega$  internal conductor resistance
- Output voltage proportional to AC and DC current
- Min. sensing current 0~60A at 5V voltage supply
- High Sensitivity 32mV/A
- Wide operating voltage range 3.0~12 V.
- Low operating current 3mA
- Nearly zero magnetic hysteresis.
- Ratiometric output from supply voltage
- 23K Hz bandwidth
- Isolation voltage 1000V



### Functional Description :

The Winson WCS2750 provides economical and precise solution for both DC and AC current sensing in industrial, commercial and communications systems. The unique package allows for easy implementation by the customer. Typical applications include motor control, load detection and management, over-current fault detection and any intelligent power management system etc...

The WCS2750 consists of a precise, low-temperature drift linear hall sensor IC with temperature compensation circuit and a current path with 85  $\mu\Omega$  typical internal conductor resistance. This extremely low resistance can effectively reduce power loss, operating temperature and increase the reliability greatly. Applied current flowing through this conduction path generates a magnetic field which is sensed by the integrated Hall IC and converted into a proportional voltage.

The terminals of the conductive path are electrically isolated from the sensor leads. This allow the WCS2750 current sensor to be used in applications requiring electrical isolation without the use of opto-isolators or other costly isolation techniques and make system more competitive in cost.

Winson reserves the right to make changes to improve reliability or manufacturability.

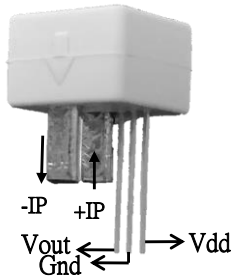

**Vout vs. Primary Current**

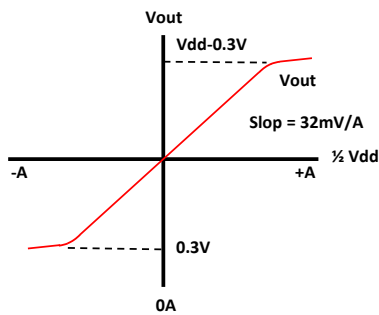

### Absolute Maximum Range

Supply Voltage, Vdd	-----	14V
Pass Current, IP	-----	120A
Output Current Sink	-----	0.4mA
Output Current Source	-----	2mA
Basic Isolation Voltage	-----	1000V
Operating Temperature Range, Ta	-----	-20°C to +125°C
Storage Temperature Range, Ts	-----	-65°C to +150°C
Power Dissipation, Pd	-----	1W

### Order Information

( Vdd = 5V )

Part No.	Sensitivity	Current range
WCS2750	32mV/A	DC: ±0 ~ 60A
		AC: rms 40A

### Function Block:

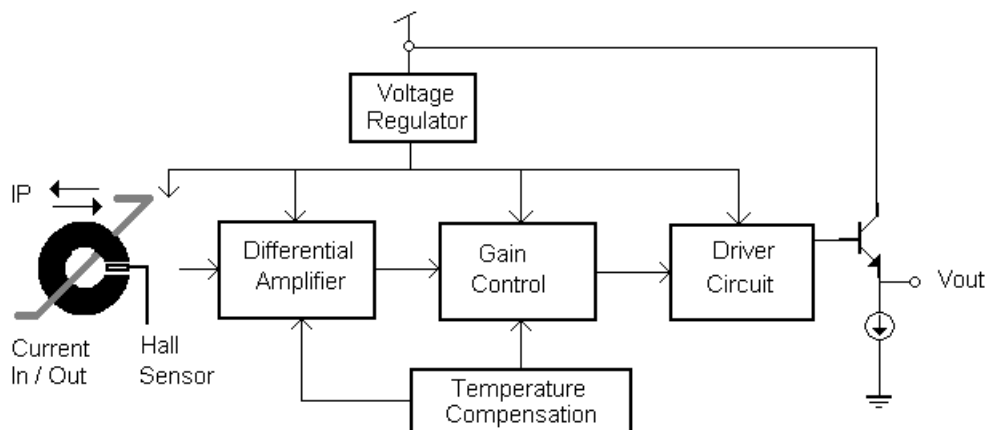

Winson reserves the right to make changes to improve reliability or manufacturability.

**Electrical Characteristics:**
**(T=+25°C, Vdd=5.0V)**

Characteristic	Symbol	Test Conditions	Min	Typ	Max	Units
Supply Voltage	Vdd	—	3.0	—	12	V
Supply Current	I <sub>supply</sub>	IP = 0 A	—	3.5	6.0	mA
Zero Current Vout	V <sub>0G</sub>	IP = 0 A	2.4	2.5	2.6	V
Primary Conductor Resistance	R <sub>primary</sub>	IP = 10 A	—	85	—	μΩ
Sensitivity	ΔV <sub>out</sub>	IP = ±10 A	27	32	37	mV/A
Bandwidth	BW	—	—	23	—	kHz
Measurable Current Range	MCR	Vdd=5V (DC Mode)	—	±60	—	A
		Vdd=5V (AC RMS)	—	40	—	
Temperature Drift	ΔV <sub>out</sub>	IP = 0 A	—	±0.5	—	mV/°C
Output Noise	V <sub>Np-p</sub>	IP = 0 A	—	7.5	—	mV
	V <sub>Np-p(0.01uF)</sub>	IP = 0 A, C = 0.01uF	—	1	—	

1. All output-voltage measurements are made with a voltmeter having an input impedance of at least 100kΩ
2. Do not apply any 'resistor load' on output pin, it will degrade IC's performance.

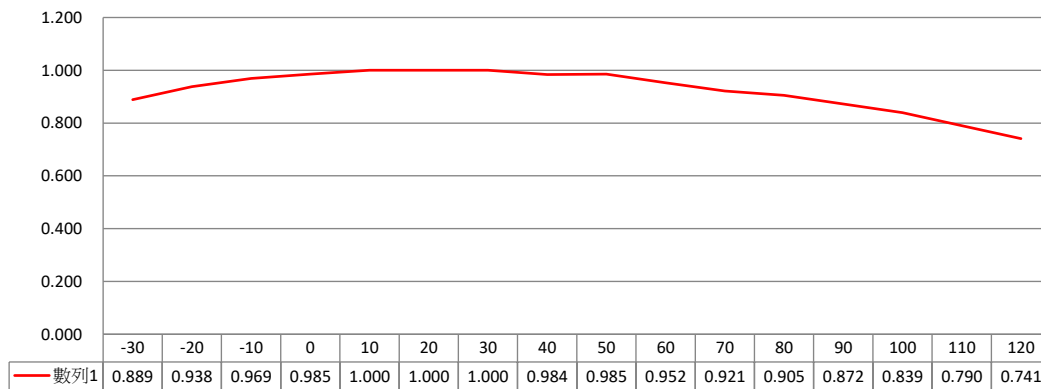
**Electrical Diagram:**
**WCS2750 Sensitivity standardization of 30°C (5V) V.S Temperature**

Winson reserves the right to make changes to improve reliability or manufacturability.

---

**Application Circuit:**

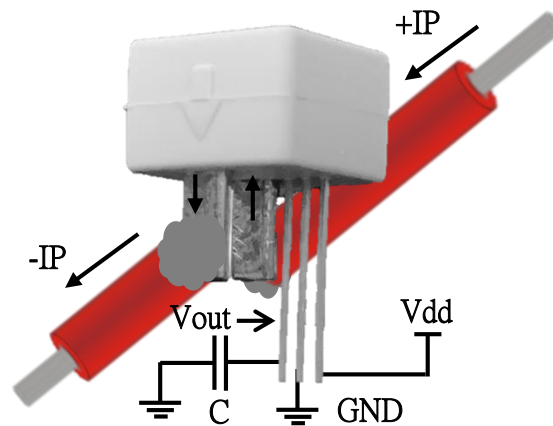

Capacitor **C**(0.01uF~0.1uF) is recommend to be connected between Vout and GND to reduce output noise.

