

Single-Phase Full-Wave Motor Driver with Built-in Hall Sensor

Features

- On-chip Hall Sensor
- Silent Driver
- High Sensitivity Hall Effect Sensor IC: +15G
- Built-in Reverse Voltage Protection Circuit
- Built-in Soft Start Function
- Built-in PWM Soft Switch Function
- Built-in Variable Speed Curve Function
- Built-in Current Limit Circuit
- Built-in Lock Protection and AutoRestart Function
- Built-In Quick Start Function
- FG (Rotation Speed Detection) Output
- Built-in Thermal Protection Circuit
- Design Reference for AEC-Q100 Grade2 Compliant

General Description

The APX9178H is an integrated Hall Effect Sensor IC designed for electric commutation of single-phase DC brushless motor applications. The device is built-in lock protection. When fan is locked, the device will enter the lock protection mode. It is also with thermal shutdown function. The APX9178H is available in a low cost DFN3x3-10B package.

Pin Configuration

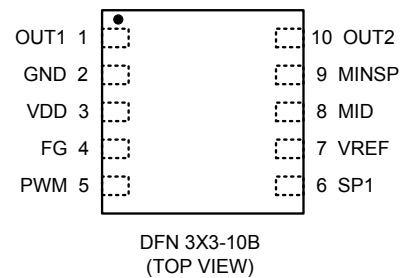

Applications

- Brushless DC Fans
- Brushless DC Motors

Ordering and Marking Information

<p>APX9178H □□□-□□□</p> <div style="margin-left: 20px;"> <p>└─ Assembly Material</p> <p>└─ Handling Code</p> <p>└─ Temperature Range</p> <p>└─ Package Code</p> </div>	<p>Package Code QA : DFN 3×3-10B</p> <p>Operating Ambient Temperature Range I : -40 to 105 °C</p> <p>Handling Code TR : Tape & Reel</p> <p>Assembly Material G : Halogen and Lead Free Device</p>
<p>APX9178H QA : APX 9178H XXXXX</p>	<p>XXXXX - Date Code</p>

Note: ANPEC lead-free products contain molding compounds/die attach materials and 100% matte tin plate termination finish; which are fully compliant with RoHS. ANPEC lead-free products meet or exceed the lead-free requirements of IPC/JEDEC J-STD-020C for MSL classification at lead-free peak reflow temperature. ANPEC defines "Green" to mean lead-free (RoHS compliant) and halogen free (Br or Cl does not exceed 900ppm by weight inhomogeneous material and total of Br and Cl does not exceed 1500ppm by weight).

ANPEC reserves the right to make changes to improve reliability or manufacturability without notice, and advise customers to obtain the latest version of relevant information to verify before placing orders.

Absolute Maximum Ratings

Symbol	Parameter	Rating	Unit
V _{DD}	VDD Pin Supply Voltage (VDD to GND)	-30 to 30	V
V _{OUT}	Output Pin (OUT1, OUT2) Output Voltage	-0.3 to 28	V
I _{OUT}	Output Pin (OUT1, OUT2) Maximum Output Current – Continuous	500	mA
	Hold	1000	
V _{PWM}	PWM Pin Input Voltage	-0.3 to 20	V
	FG Pin Output Voltage	-0.3 to 20	V
I _{FG}	FG Pin Output Sink Current	10	mA
I _{VREF}	VREF Pin Maximum Output Current	10	mA
V _{MINSP}	MINSP Pin Input Voltage (MINSP to GND)	0 to 7	V
V _{MID}	MID Pin Input Voltage (MID to GND)	0 to 7	V
V _{SP1}	SP1 Pin Input Voltage (SP1 to GND)	0 to 7	V
T _J	Maximum Junction Temperature	165	°C
T _{STG}	Storage Temperature	-65 to 165	°C
T _{SOR}	Maximum Lead Soldering Temperature, 10 Seconds	260	°C

Note1: Stresses above those listed in “Absolute Maximum Ratings” may cause permanent damage to the device.

Thermal Characteristics

Symbol	Parameter	Typical Value	Unit
R _{TH,JA}	Thermal Resistance-Junction to Ambient DFN3x3-10B	138.9	°C/W
P _D	Power Dissipation, T _A = 25°C DFN3x3-10B	0.9	W

Note 2 : The maximum allowable power dissipation at any T_A (ambient temperature) is calculated using: P_D=(T_J - T_A) / R_{TH,JA}; T_J = 165°C. Exceeding the maximum allowable power dissipation will result in excessive die temperature.

Recommended Operating Conditions

Symbol	Parameter	Range	Unit
V _{DD}	VDD Supply Voltage	4 to 19	V
V _{MINSP}	MINSP Pin Input Voltage (MINSP to GND)	0 to V _{VREF}	V
V _{MID}	MID Pin Input Voltage (MID to GND)	0 to V _{VREF}	V
V _{SP1}	SP1 Pin Input Voltage (SP1 to GND)	0 to V _{VREF}	V
T _A	Operating Ambient Temperature	-40 to 105	°C
T _J	Junction Temperature	-40 to 150	°C

Electrical Characteristics (T_A=25°C, V_{DD}=12V, unless otherwise noted)

Symbol	Parameter	Test Condition	APX9178H			Unit
			Min.	Typ.	Max.	
SUPPLY CURRENT						
I _{DD}	Operation Mode	V _{DD} =12V, No Load	-	6	9	mA
I _{LOCK}	Lock Mode	V _{DD} =12V, No Load	-	5.5	8.5	mA
I _{STANDBY}	Standby Mode	PWM=GND	-	300	450	μA
I _{INR}	Reverse Supply current	V _{DD} =-20V	-	-	1	mA
V _{VREF}	VREF Pin Output Voltage	I _{VREF} = 5mA	2.3	2.45	2.6	V
OUTPUT DRIVERS						
V _O	Output Driver Saturation Voltage	I _{OUT} = 300 mA , Upper and Lower total	-	0.285	0.43	V
V _{FG}	FG Pin Low Voltage	I _{FG} =5mA	-	0.1	0.15	V
I _{FGL}	FG Pin Off Leakage Current	V _{FG} =12V	-	<0.1	1	μA
V _{FGT}	FG Pin Current Limit Trigger Level	B<BRP	1	-	1.5	V
PWM CONTROL						
V _{PWMH}	Pulse Mode PWM Input High Level Voltage		2	-	5	V
V _{PWML}	Pulse Mode PWM Input Low Level Voltage		-0.3	-	0.8	V
F _{PWM}	PWM Input Frequency		0.3	-	50	KHz
F _{OUT}	Output PWM Switch Frequency		20	23.5	27	KHz
R _{PWM_PU}	PWM Internal pull-up Resistor	PWM=GND	-	16	-	KΩ
V _{PWM_PU}	PWM Internal pull-up Voltage		-	4.8	-	V
D _{ODCR}	OUTPUT Duty Change Rate		-	90	-	%/sec
DC _{Gap}	Duty Cycle Mismatch	DC _{Gap} = DC _{OUT} - DC _{Target}	-2	-	2	%
LOCK PROTECTION						
T _{LDT}	Lock Protection Detection Time		-	0.3	-	sec
T _{ON}	Lock Protection Detection On Time		0.6	0.75	0.9	sec
T _{OFF}	Lock Protection Detection Off Time		3.6	4.5	5.4	sec
T _{QS}	Quick Start Enable Time		-	60	-	ms
Soft Start						
T _{SS}	Soft Start Time	PWM Input Duty=100%, (Dout 30 to 100%)	-	0.75	-	sec
D _{SS}	Soft Start Initial Duty		-	30	-	%
POWER PROTECTION						
I _{LIM1}	Current Limit Level of Start up		-	0.55	-	A
I _{LIM2}	Current Limit Level of Normal Operation		-	1	-	A
I _{LIM_HV}	Current Limit Level of high voltage	V _{DD} >V _{DD_HV}	-	0.25	-	A
V _{DD_HV}	I _{LIM_HV} trigger Level	V _{DD} rising	15	15.5	16	V
	Hysteresis of V _{DD_HV}		-	0.5	-	V
V _{OVp}	Over Voltage Protection Threshold Level	V _{DD} >V _{OVp} , shutdown output	22	-	25	V
THERMAL PROTECTION						
	Over-Thermal Protection Temperature		-	170	-	°C
	Over -Thermal Protection Hysteresis		-	30	-	°C
	Thermal Protection release time		-	2	-	sec

Magnetic Characteristics (T_A=25°C, V_{DD}=12V, unless otherwise noted)^{Note 3}

Symbol	Parameter	Test Condition	APX9178H			Unit
			Min.	Typ.	Max.	
Bop	Magnetic Operation Point		0	15	30	Gauss
Brp	Magnetic Release Point		-30	-15	-0	Gauss
Bhys	Magnetic Hysteresis		-	30	-	Gauss

Note 3: The Magnetic of fan recommend more than 35 gauss.

Pin Description

PIN		Function
NO.	NAME	
1	OUT1	H-bridge output connection. The output stage is a H-bridge formed by four transistors and four-protection diode for switching applications.
2	GND	Ground of the IC.
3	VDD	Supply Voltage Input
4	FG	Rotation Speed Output. This is an open-drain output.
5	PWM	PWM Signal Input Terminal.
6	SP1	Input Duty Setting For Turning Point ($D_{I^{SP1}}$).
7	VREF	Regulator Output.
8	MID	Output Duty Setting ($D_{O^{MID}}$) For Turning Point ($D_{I^{MID}}$).
9	MINSP	Minimum Output Duty setting.
10	OUT2	H-bridge output connection. The output stage is a H-bridge formed by four transistors and four-protection diode for switching applications.

I/O Equivalent Circuit

(1) Power supply input pin (VDD)

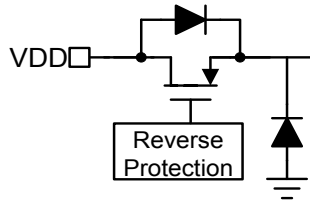

(2) Regulator output pin (VREF)

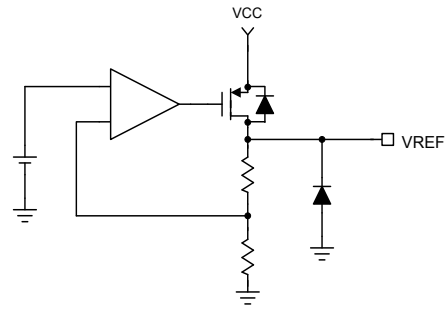

(3) Driver output pin (OUT1, OUT2)

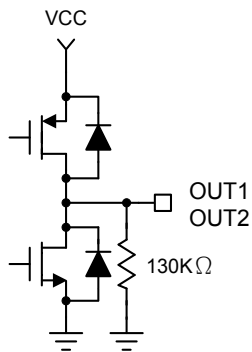

(4) Rotation speed output pin (FG)

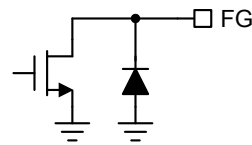

(5) PWM speed control input pin (PWM)

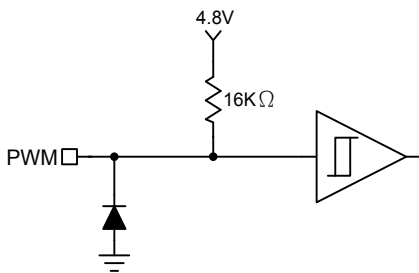

(6) Input and output duty setting input pin (SP1, MINSP)

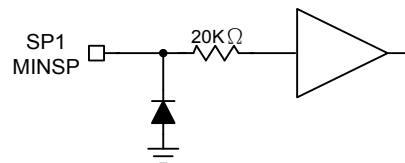

I/O Equivalent Circuit (Cont.)

(7) Input and output duty setting input pin (MID)

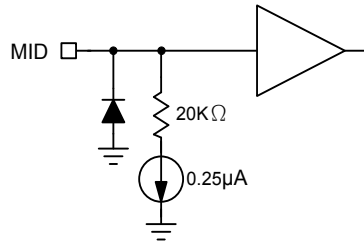

Block Diagram

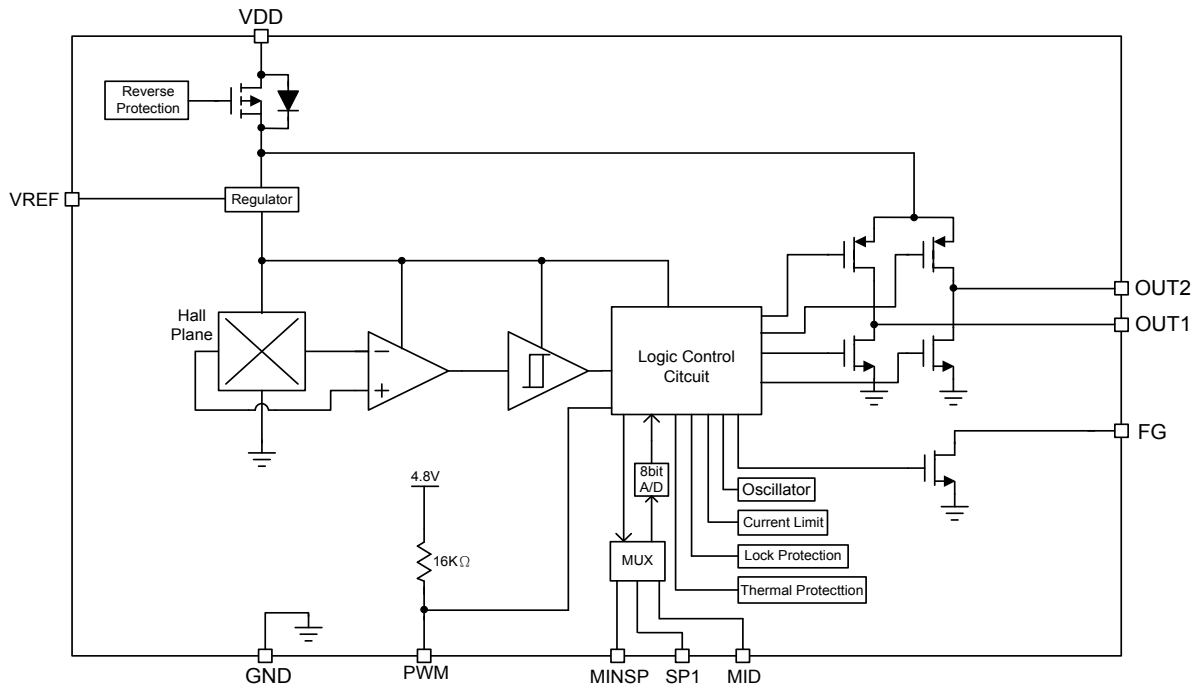

Typical Application Circuit

(1) Multi Mode Output Duty Control Circuit

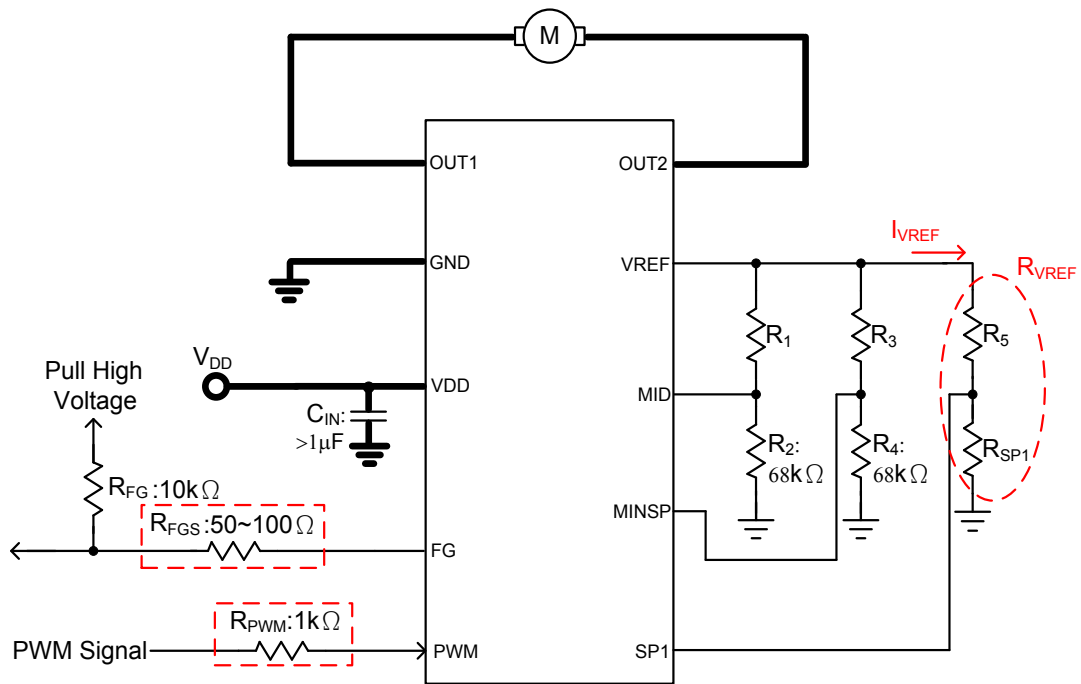

Note : $R_{VREF} = (R_5 + R_{SP1})$.

Note 1 : $(R_1 + R_2)$ and $(R_3 + R_4)$ must more than 68 KΩ.

Note 2 : The C_{IN} value is adjusted by motor characteristic.

Note 3 : R_{PWM} and R_{FGS} are optional to protect internal circuit for abnormal voltage stress.

Typical Application Circuit (Cont.)

(2) Shutdown Mode Output Duty Control Circuit

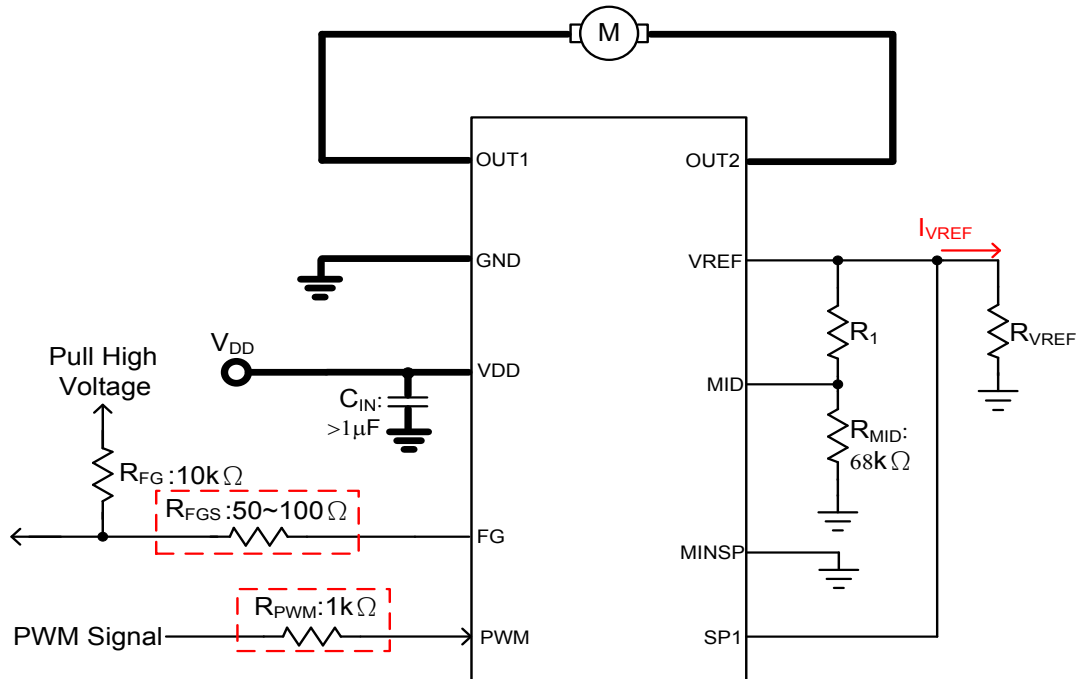

Note: ($R_1 + R_{MID}$) must more than 68 KΩ.

Note 1 : The C_{IN} value is adjusted by motor characteristic.

Note 2 : R_{PWM} and R_{FGS} are optional to protect internal circuit for abnormal voltage stress.

Typical Application Circuit (Cont.)

(3) Minimum Speed Mode Output Duty Control Circuit

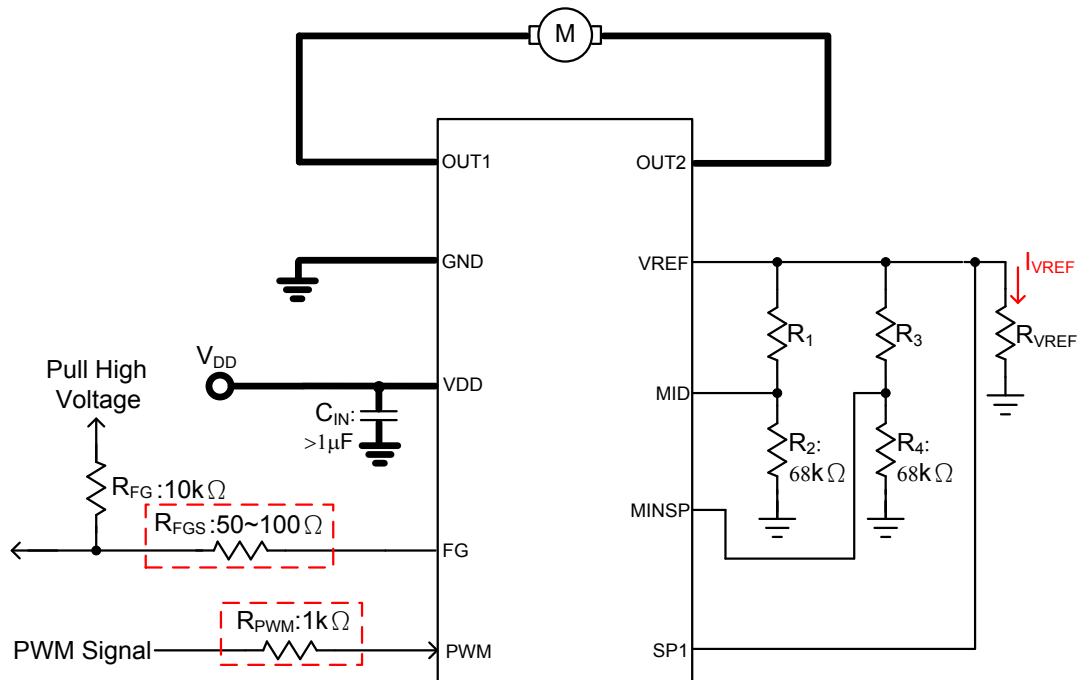

Note : $(R_1 + R_2)$ and $(R_3 + R_4)$ must more than 68 K Ω .

Note 1 : The C_{IN} value is adjusted by motor characteristic.

Note 2 : R_{PWM} and R_{FGS} are optional to protect internal circuit for abnormal voltage stress.

Typical Application Circuit (Cont.)

(4) Linear Output Duty Control Circuit

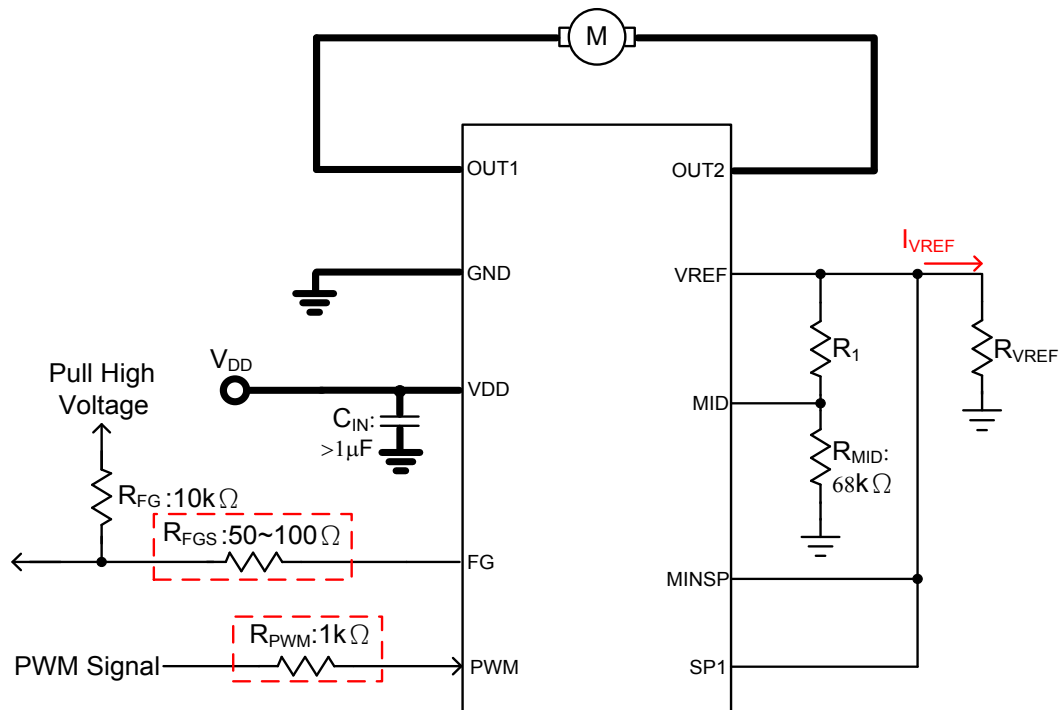

Note: $(R_1 + R_{MID})$ must more than 68 K Ω .

Note 1 : The C_{IN} value is adjusted by motor characteristic.

Note 2 : R_{PWM} and R_{FGS} are optional to protect internal circuit for abnormal voltage stress.

Function Descriptions

Output Switch Principle

The APX9178H built in a Hall-effect sensor plane to sense the vertical magnetic flux density (B). There are two output drivers in APX9178H to drive single-phase DC brushless motor. When the N pole magnetic field close to the IC marking surface and the magnetic flux density higher than operate point (Brp), the OUT1 pin output will turn to LOW and the OUT2 pin output will turn to HIGH. When the N pole magnetic field far away the IC marking surface and S pole magnetic field close to the IC marking surface until the magnetic flux density higher than release point (Bop), the OUT1 pin output will turn HIGH and the OUT2 pin output will turn LOW.

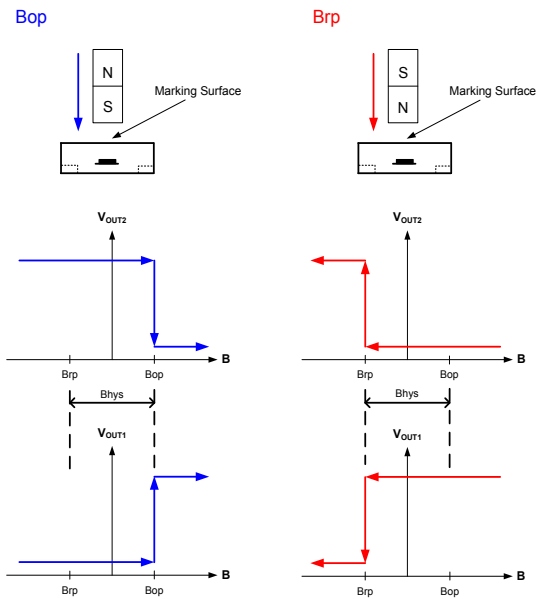

Lockup Protection and Automatic Restart

The APX9178H detects the rotation of the motor by internal hall sensor signal, and adjusts lock detection ON time (T_{ON}) and lock detection OFF time (T_{OFF}) by internal counter.

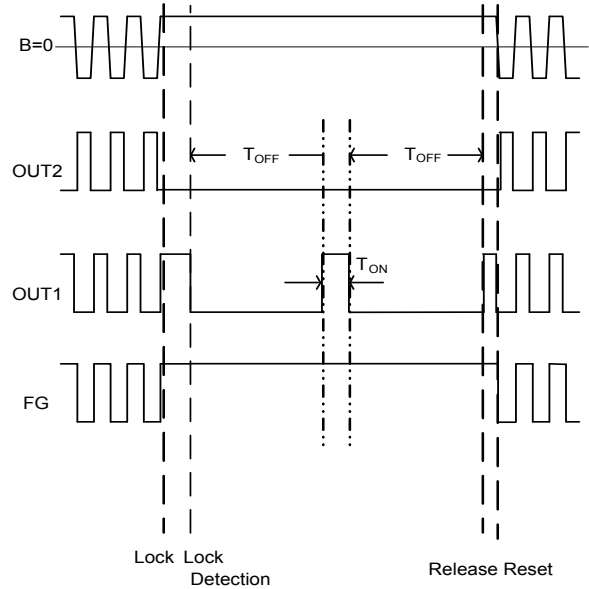

Function Descriptions (Cont.)

PWM Soft-Switch Function

The APX9178H built in PWM soft-switch output control circuit to improve the vibration and noise of fan motor operation. At start-up operation, the APX9178H drive the output driver by square wave to force the fan motor start to rotate. After several square wave outputs, the internal PWM soft-switch control circuit will be enable to drive fan motor to improve vibration and noise.

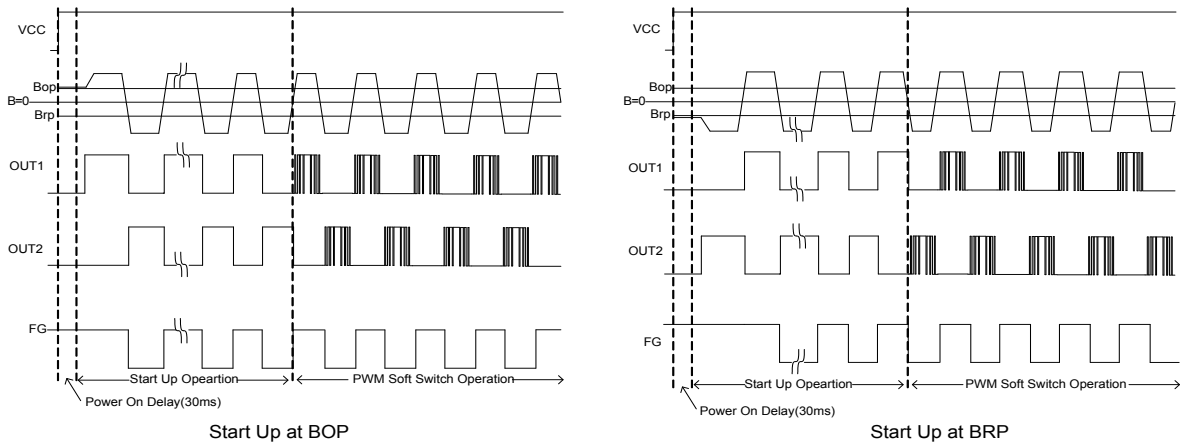

Quick Start and Standby Mode

This IC would enter standby mode when the PWM input keeps low level for then 60ms (typ.). In standby mode, it will shutdown amplifier and FG. In standby mode, the lock protection function doesn't work, therefore, starting fan is unobstructed when releasing standby mode. In addition, the OUT1, OUT2 and FG reference above figure start up operation.

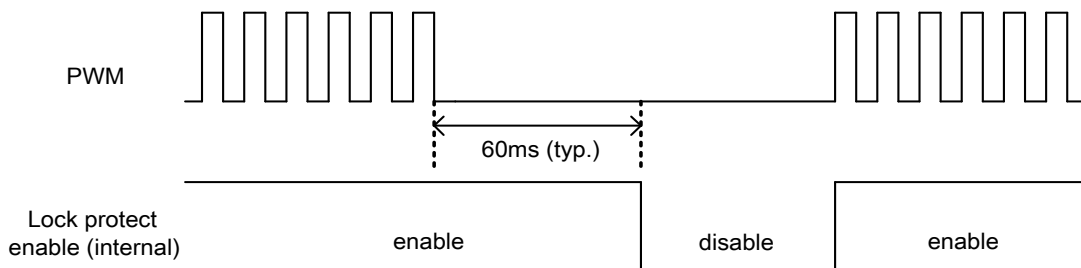

Function Descriptions (Cont.)

Soft-Switch Function

The APX9178H provides the soft-start function to avoid peak current at power-on and lock-restart moments. The softstart function initial duty is 30%, if hall sensor signal change eight times the duty will trace input target duty, else duty from 30% to 100% in 0.75 sec.

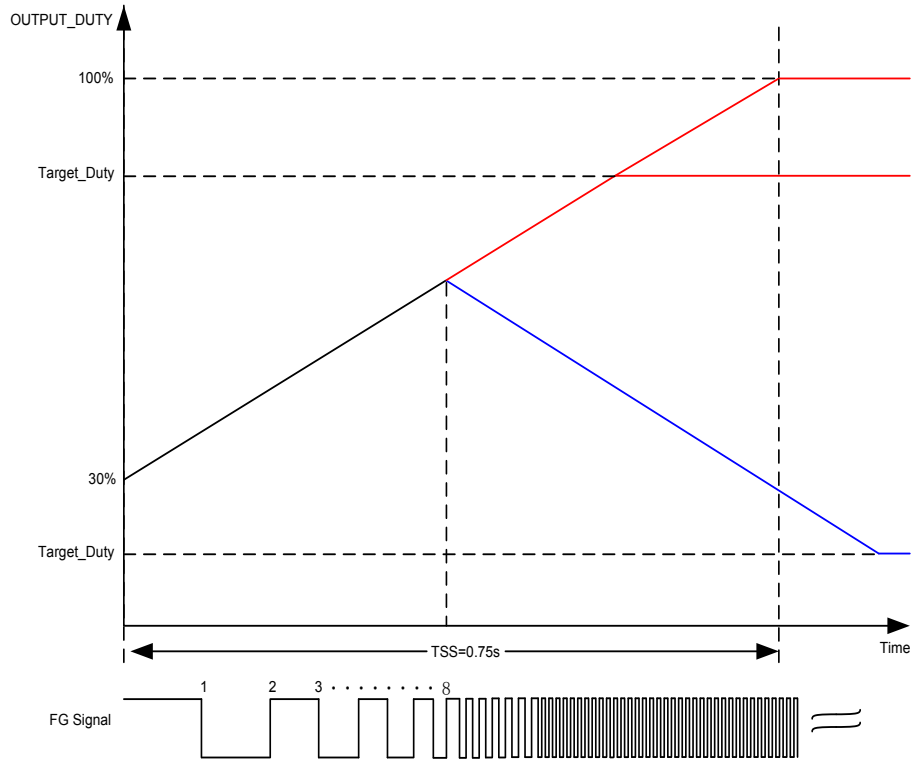

Function Descriptions (Cont.)

Speed Control by Direct PWM Input Signal

The APX9178H has two types PWM speed control curve, it select by SP1 pin voltage setting. The first type of PWM speed control curve (See Figure1: Multi Mode Output Duty Control Curve), it can set up low duty shutdown mode or minimum speed mode by VREF pin output current (I_{VREF}) decision and the SP1 pin set up range is GND to VREF-0.3V. In this type (1), when PWM input duty is less than DI_{SP1} , the output will close. Until PWM input duty is rising more than $DI_{SP1}+3.9\%$, the output will startup.

In this type (2), when PWM input duty is less than DI_{SP1} , the output duty will keep DO_{MIN} . All of above case, it can insert DI_{MID} to change the speed curve slope. If DI_{MID} isn't using, the MID pin is floating.

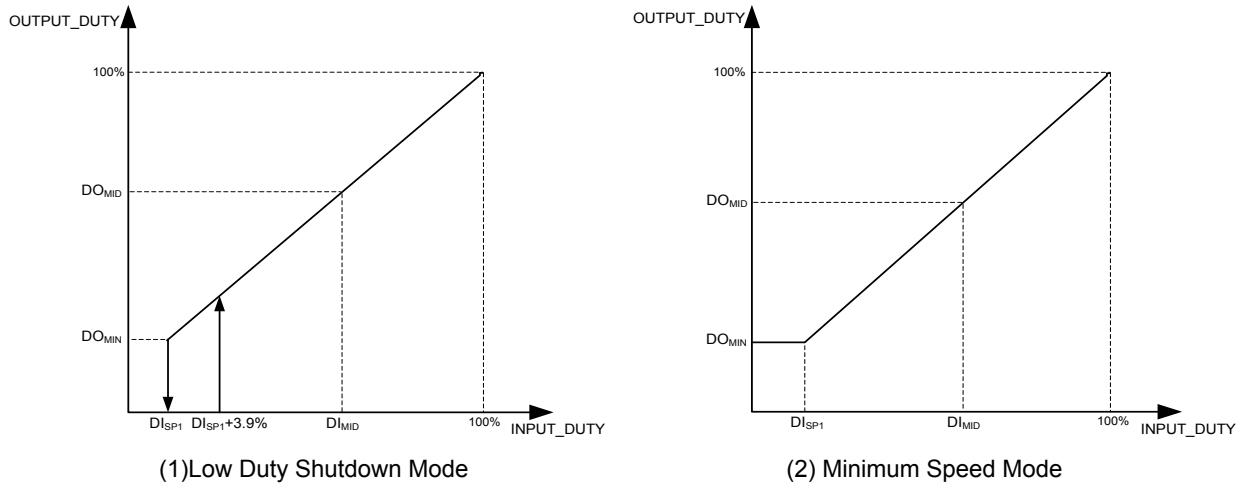

Figure1: Multi Mode Output Duty Control Curve

Note : $DO_{MIN} = \frac{V_{MINS\bar{P}}}{V_{VREF}} \times 100\%$, $DO_{MID} = \frac{V_{MID}}{V_{VREF}} \times 100\%$, $DI_{SP1} = \frac{V_{SP1}}{V_{VREF}} \times 100\%$

Note1 : $DI_{MID} = \frac{DI_{SP1} + 100\%}{2}$

Note2 : DO_{MID} don't less than DO_{MIN}

Function Descriptions (Cont.)

The R_{VREF} recommend for setting up multi mode output duty control curve, it is reference the table1.

Table1. R_{VREF} reference resistance

R_{VREF}	Output Speed Control Curve Mode
OPEN ~ 12k Ω ($I_{VREF}=0 \sim 0.21mA$)	Low Duty Shutdown Mode
4.7k Ω ~ 2.2k Ω ($I_{VREF}=0.53\sim 1.13mA$)	Minimum Speed Mode

The second type of PWM speed control curve, SP1 pin must connect to VREF pin. At this type, the speed control curve has three modes. If the MINSP pin connect to GND, the output duty control curve will has low duty shutdown function and the minimum output duty fix 10% (See Figure2: Shutdown mode Output Duty Control Curve). In this mode, it can set up four types output duty slope by VREF pin output current (I_{VREF}) decision. When PWM input duty is less than transition point, the output will keep minimum duty 10%, until the PWM input duty is less than SD- output will close. If PWM input duty is rising more than SD+, the output will startup. Otherwise, this mode can insert DI_{MID} to change the speed curve slope. If DI_{MID} isn't using, the MID pin is floating.

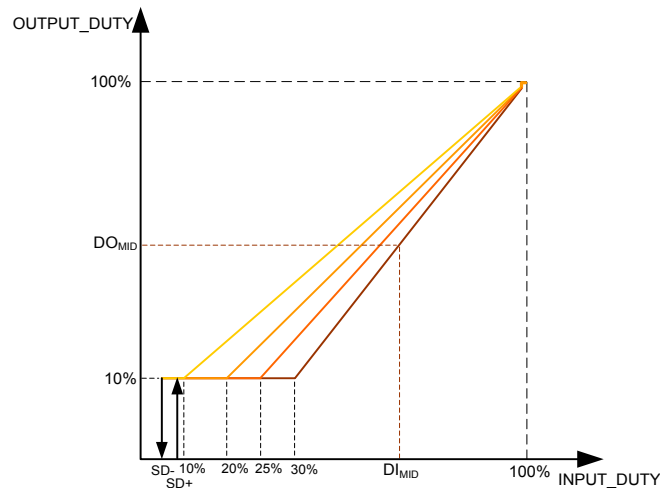

Figure 2: Shutdown mode Output Duty Control Curve

Note: $DI_{MID} = \frac{TP + 100\%}{2}$, $DO_{MID} = \frac{V_{MID}}{V_{VREF}} \times 100\%$, TP is mean Transition Point.

Note1: DO_{MID} don't less than 10%.

Note2 : The SD- typical is 5.5% and the SD+ = SD- + 3.9%.

Function Descriptions (Cont.)

The second mode, MINSP pin voltage range is GND+0.1V to VREF-0.3V and the output duty control curve with minimum speed. It can set up four types output duty slope by VREF pin output current (I_{VREF}) decision (See Figure3: Minimum speed mode Output Duty Control Curve). In this mode, MINSP can set up minimum output duty (DO_{MIN}). When PWM input duty is less than transition point, the output duty will keep minimum output duty. Otherwise, it can insert DI_{MID} to change the speed curve slope. If DI_{MID} isn't using, the MID pin is floating.

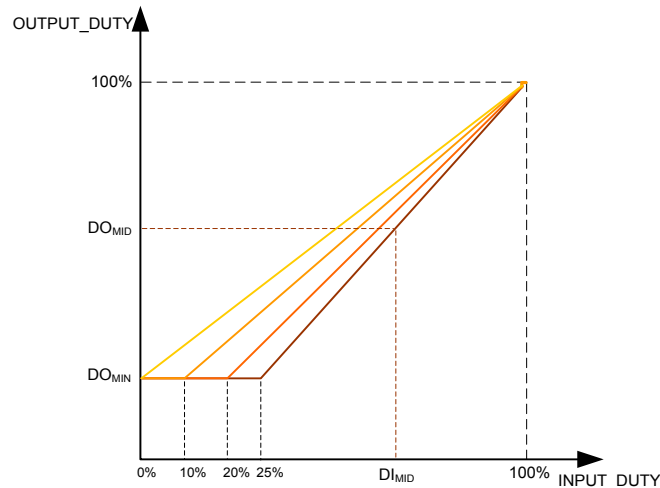

Figure3: Minimum speed mode Output Duty Control Curve

Note: $DO_{MIN} = \frac{V_{MINSP}}{V_{VREF}} \times 100\%$, $DO_{MID} = \frac{V_{MID}}{V_{VREF}} \times 100\%$

Note1: $DI_{MID} = \frac{TP + 100\%}{2}$, TP is mean Transition Point.

Note 2 : DO_{MID} don't less than DO_{MIN}

Function Descriptions (Cont.)

The third mode, if the MINS_P connect to VREF pin, it a linear slope type output duty (See Figure4: Linear Output Duty Control Curve). When PWM input duty is less than SD₋ the output will close, until PWM input duty is rising more than the SD₊ the output will startup. Otherwise, it can insert DI_{MID} to change the speed curve slope. If DI_{MID} isn't using, the MID pin is floating.

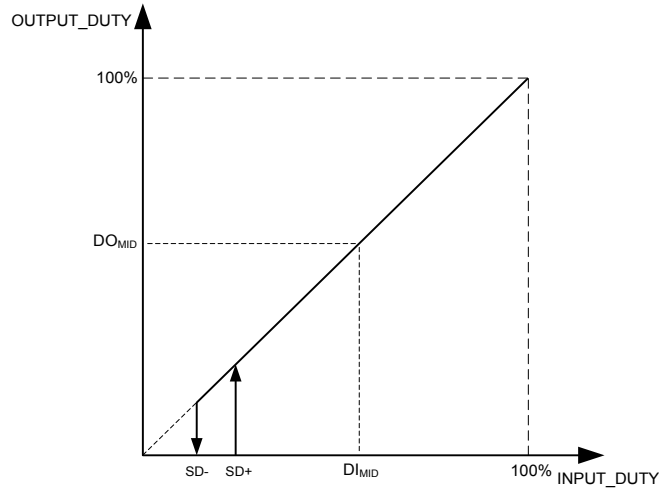

Figure 4: Linear Output Duty Control Curve

Note : $DI_{MID} = \frac{0 + 100\%}{2}$, $DO_{MID} = \frac{V_{MID}}{V_{VREF}} \times 100\%$

Note1 : DO_{MID} don't less than 10%.

Note2 : The SD₋ typical is 5.5% and the SD₊ = SD₋ + 3.9%

The R_{VREF} recommend for setting up four types output duty slop, it is reference the table2.

Table2. R_{VREF} reference resistance

R _{VREF}	Transition Point (Shut Down Mode)	Transition Point (Minimum Speed Mode)
OPEN(I _{VREF} =0mA)	10%	10%
12kΩ(I _{VREF} =0.21mA)	20%	20%
4.7kΩ(I _{VREF} =0.53mA)	25%	25%
2.2kΩ(I _{VREF} =1.13mA)	30%	0%

Function Descriptions (Cont.)

Current Limit

The APX9178H includes an internal current sense circuits for current limit. When the total current of output over the current limit level (1A), the high side driver will be turned off to stop supplying current to the motor until $I_{OUT} < 1A$ or repower on. At Start up, the current limit level will decrease to 0.55A.

FG Output

The FG pin is an open-drain output, connecting a pull up resistor to a high level voltage for the speed detection function. During the Lock Mode, the FG will always high (switch off). Open the terminal when not in use.

Thermal Protection

The APX9178H has thermal protection. When internal junction temperature reaches 165°C, the output devices will be switched off. When the IC's junction temperature cools by 30°C and wait 2 second, the thermal sensor will turn the output devices on again, resulting in a pulsed output during continuous thermal protection.

Truth Table

Input		Output			Mode
B	PWM	OUT1	OUT2	FG	
BOP	H	H	L	OFF	Operation Mode
BRP		L	H	L	
BOP	L	L	L	OFF	
BRP		L	L	L	
BOP	-	L	L	OFF	Lock Mode
BRP		L	L	OFF	
-	L	OFF	OFF	OFF	Standby Mode

Application Information

Input Capacitor

The IC in order to noise reduction purpose, a capacitor (C_{IN}) must connect between VDD and GND. It is the suggestion that C_{IN} should be placed as close as possible to the device VDD pin.

Package Information

DFN 3x3-10B

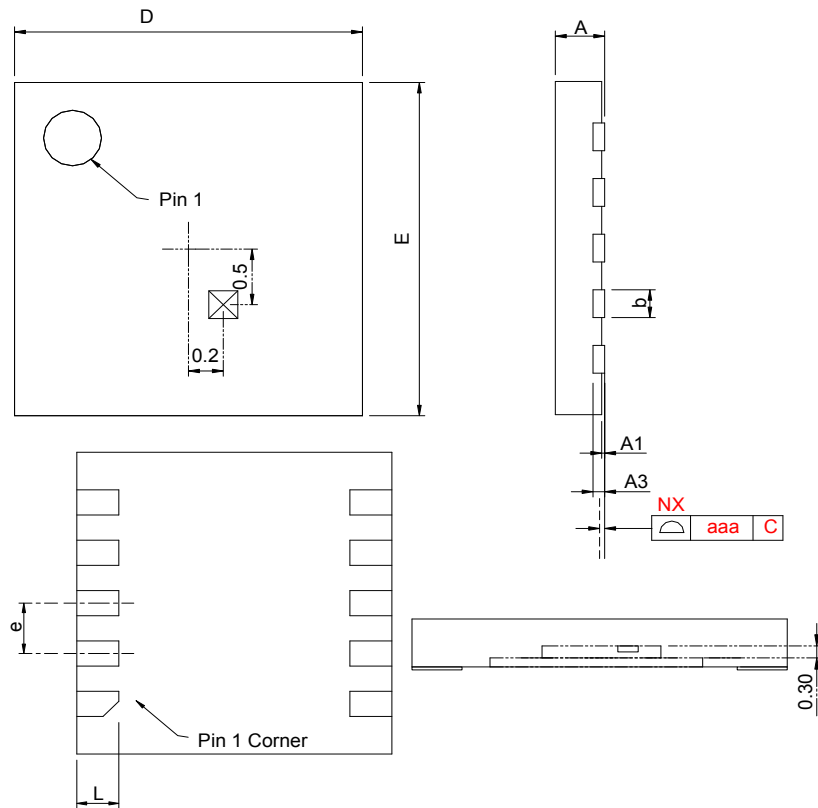

SYMBOL	DFN3*3-10B			
	MILLIMETERS		INCHES	
	MIN.	MAX.	MIN.	MAX.
A	0.80	1.00	0.032	0.039
A1	0.00	0.05	0.000	0.002
A3	0.20 REF		0.008 REF	
b	0.18	0.30	0.007	0.012
D	2.90	3.10	0.114	0.122
E	2.90	3.10	0.114	0.122
e	0.50 BSC		0.020 BSC	
L	0.45	0.55	0.018	0.022
aaa	0.08		0.003	

Carrier Tape & Reel Dimensions

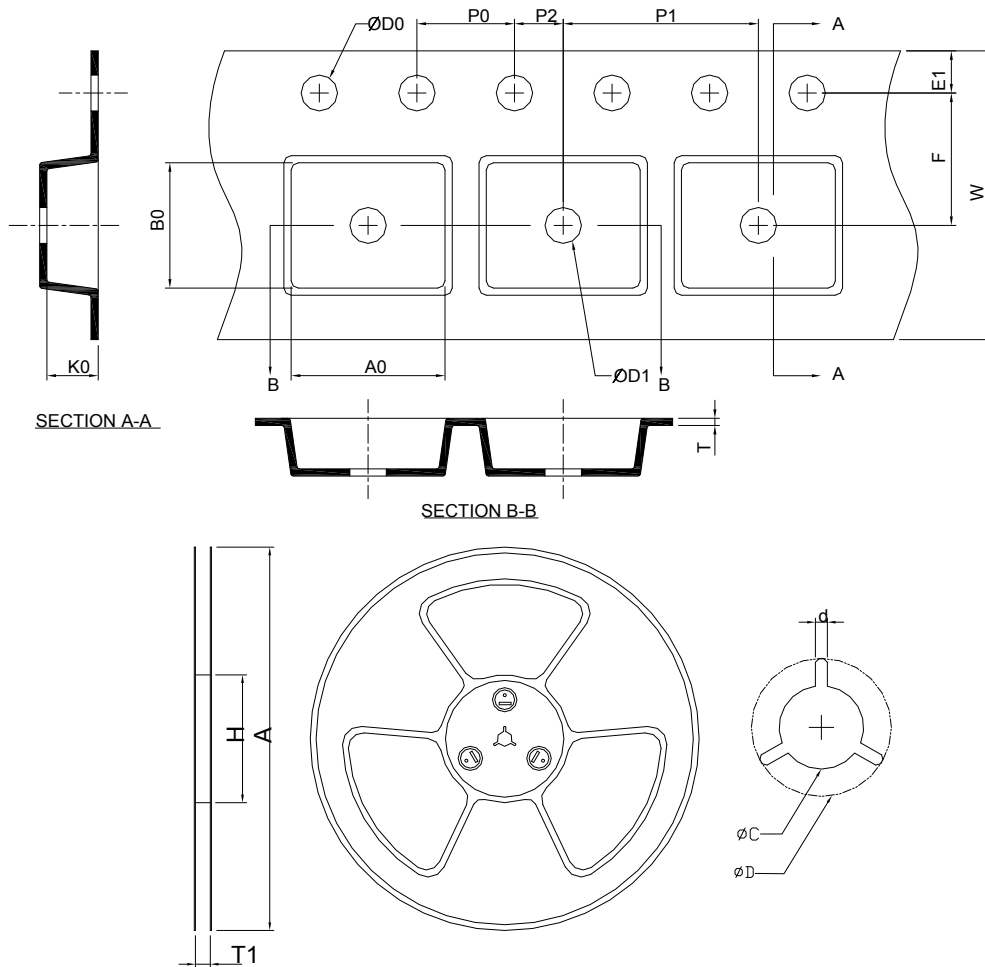

Application	A	H	T1	C	d	D	W	E1	F
DFN3x3-10B	330±2.00	50 MIN.	12.4+2.00 -0.00	13.0+0.50 -0.20	1.5 MIN.	20.2 MIN.	12.0±0.30	1.75±0.10	5.5±0.05
	P0	P1	P2	D0	D1	T	A0	B0	K0
	4.0±0.10	8.0±0.10	2.0±0.05	1.5+0.10 -0.00	1.5 MIN.	0.6+0.00 -0.40	3.30±0.20	3.30±0.20	1.30±0.20

(mm)

Devices Per Unit

Package Type	Unit	Quantity
DFN3x3-10B	Tape & Reel	3000

Taping Direction Information

DFN3x3-10B

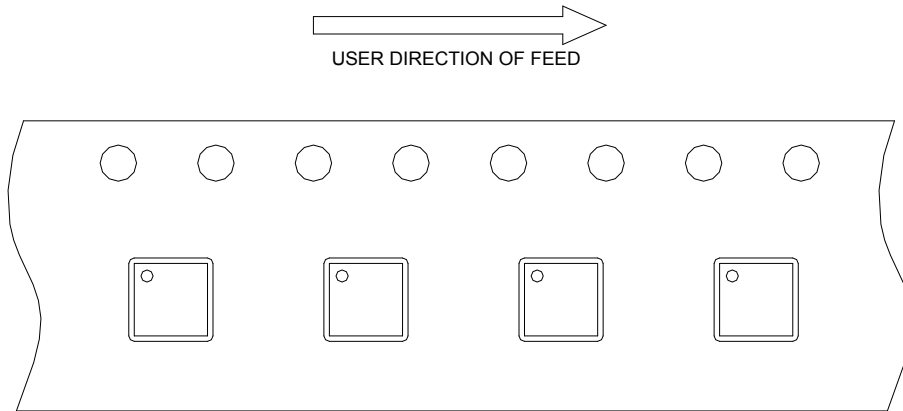

Classification Profile

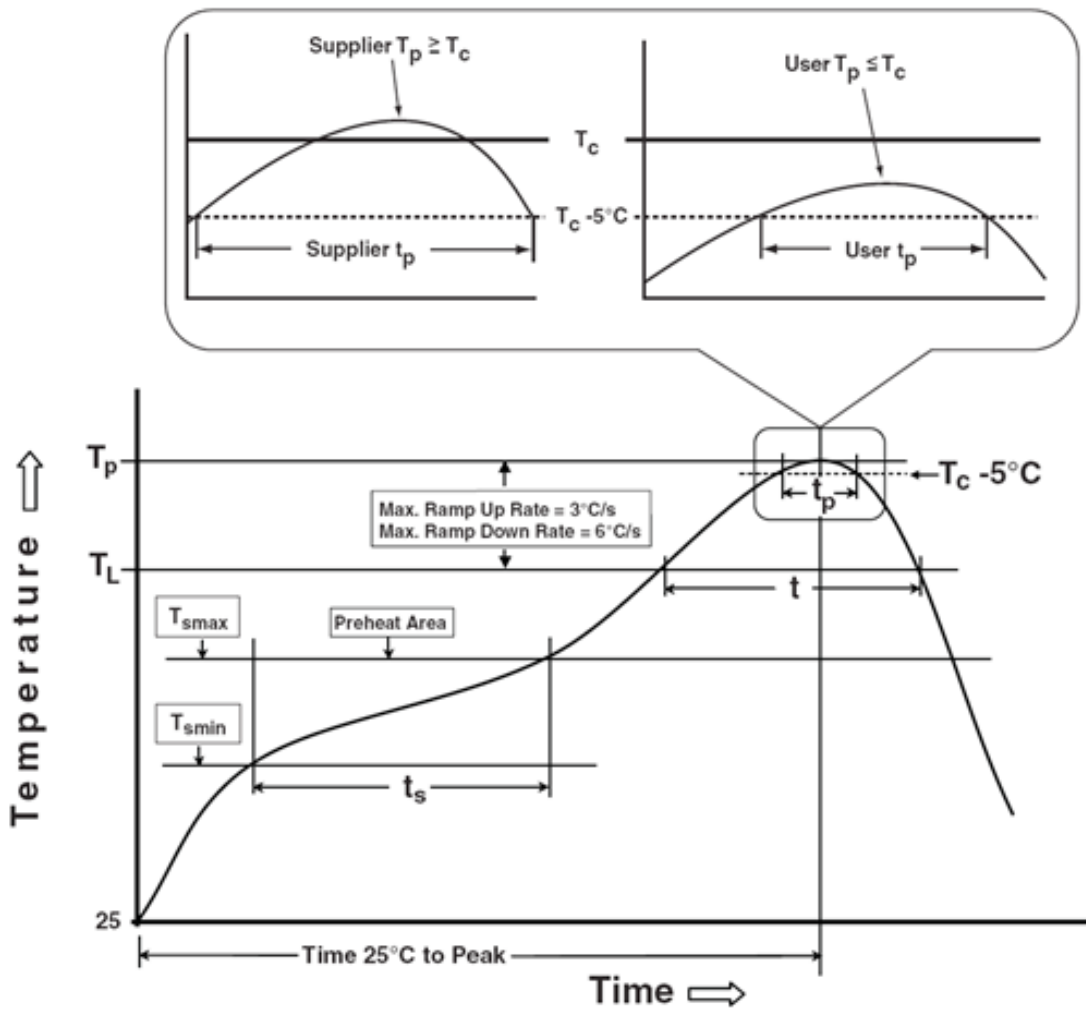

Classification Reflow Profiles

Profile Feature	Sn-Pb Eutectic Assembly	Pb-Free Assembly
Preheat & Soak		
Temperature min (T_{smin})	100 °C	150 °C
Temperature max (T_{smax})	150 °C	200 °C
Time (T_{smin} to T_{smax}) (t_s)	60-120 seconds	60-120 seconds
Average ramp-up rate (T_{smax} to T_p)	3 °C/second max.	3°C/second max.
Liquidous temperature (T_L)	183 °C	217 °C
Time at liquidous (t_L)	60-150 seconds	60-150 seconds
Peak package body Temperature (T_p)*	See Classification Temp in table 1	See Classification Temp in table 2
Time (t_p)** within 5°C of the specified classification temperature (T_c)	20** seconds	30** seconds
Average ramp-down rate (T_p to T_{smax})	6 °C/second max.	6 °C/second max.
Time 25°C to peak temperature	6 minutes max.	8 minutes max.
* Tolerance for peak profile Temperature (T_p) is defined as a supplier minimum and a user maximum.		
** Tolerance for time at peak profile temperature (t_p) is defined as a supplier minimum and a user maximum.		

Table 1. SnPb Eutectic Process – Classification Temperatures (T_c)

Package Thickness	Volume mm ³	
	<350	>350
<2.5 mm	235 °C	220 °C
≥2.5 mm	220 °C	220 °C

Table 2. Pb-free Process – Classification Temperatures (T_c)

Package Thickness	Volume mm ³		
	<350	350-2000	>2000
<1.6 mm	260 °C	260 °C	260 °C
1.6 mm – 2.5 mm	260 °C	250 °C	245 °C
≥2.5 mm	250 °C	245 °C	245 °C

Reliability Test Program

Test item	Method	Description
SOLDERABILITY	JESD-22, B102	5 Sec, 245°C
HOLT	JESD-22, A108	1000 Hrs, Bias @ $T_j=125^\circ\text{C}$
PCT	JESD-22, A102	168 Hrs, 100%RH, 2atm, 121°C
TCT	JESD-22, A104	500 Cycles, -65°C~150°C
HBM	MIL-STD-883-3015.7	VHBM ≥ 2KV
MM	JESD-22, A115	VMM ≥ 200V
Latch-Up	JESD 78	10ms, $1_{tr} \geq 100\text{mA}$

Customer Service

Anpec Electronics Corp.

Head Office :

No.6, Dusing 1st Road, SBIP,

Hsin-Chu, Taiwan, R.O.C.

Tel : 886-3-5642000

Fax : 886-3-5642050

Taipei Branch :

2F, No. 11, Lane 218, Sec 2 Jhongsing Rd.,

Sindian City, Taipei County 23146, Taiwan

Tel : 886-2-2910-3838

Fax : 886-2-2917-3838