

## Single-Phase Full-Wave Motor Driver for Silent Fan Motor

### Features

- **Single-Phase Full Wave Fan Driver**
- **Silent Driver**
- **Low Supply Current**
- **Speed Controllable by PWM Input Signal**
- **Built-in Quick Start Function**
- **Built-in Lock Protection and Auto Restart Function (External Capacitor Unnecessary)**
- **Enhance Low Duty Start UP Power**
- **1/2 FG Output**
- **Include Hall Bias Circuit**
- **Built-in Current Limit Circuit**
- **Built-in Thermal Protection Circuit**
- **Lead Free and Green Devices Available (RoHS Compliant)**

### General Description

The APX9275A is a single phase full wave motor driver for DC fan motors, and can apply to three type speed control methods. The output signals of this IC are the amplifications of hall input signals. It is suitable for both game machine and CPU cooler that need silent fans. The device is built-in lock protection, when fan is locked, the device will enter the lockup protection mode. It is also with thermal shutdown function. In normal operation, the supply current is less than 8mA. The APX9275A is available in MSOP-10 and SOP-10 packages.

### Applications

- **Motor Drivers for Silent Fans**

### Pin Configuration

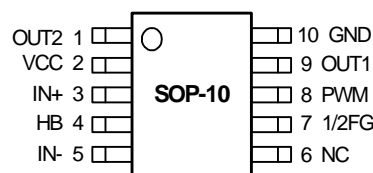
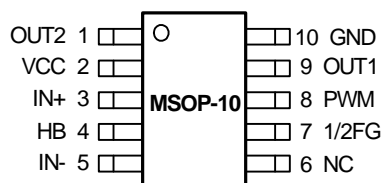

ANPEC reserves the right to make changes to improve reliability or manufacturability without notice, and advise customers to obtain the latest version of relevant information to verify before placing orders.

## Ordering and Marking Information

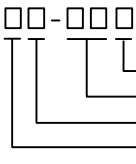
<p>APX9275A</p> 	<p>Package Code  X: MSOP - 10 K:SOP-10  Operating Ambient Temperature Range  I: -40 to 110 °C  Handling Code  TR : Tape &amp; Reel  Assembly Material  G: Halogen and Lead Free Device</p>			
<p>APX9275A X :</p> <table border="1" style="display: inline-table; margin-left: 20px;"> <tr><td style="padding: 2px;">9275A</td></tr> <tr><td style="padding: 2px;">XXX</td></tr> <tr><td style="padding: 2px;">○ XX</td></tr> </table>	9275A	XXX	○ XX	<p>XXXXX - Date Code</p>
9275A				
XXX				
○ XX				
<p>APX9275A K :</p> <table border="1" style="display: inline-table; margin-left: 20px;"> <tr><td style="padding: 2px;">APX9275A</td></tr> <tr><td style="padding: 2px;">XXXXX</td></tr> <tr><td style="padding: 2px;">○</td></tr> </table>	APX9275A	XXXXX	○	<p>XXXXX - Date Code</p>
APX9275A				
XXXXX				
○				

Note: ANPEC lead-free products contain molding compounds/die attach materials and 100% matte tin plate termination finish; which are fully compliant with RoHS. ANPEC lead-free products meet or exceed the lead-free requirements of IPC/JEDEC J-STD-020D for MSL classification at lead-free peak reflow temperature. ANPEC defines “Green” to mean lead-free (RoHS compliant) and halogen free (Br or Cl does not exceed 900ppm by weight in homogeneous material and total of Br and Cl does not exceed 1500ppm by weight).

## Absolute Maximum Ratings (Note 1)

Symbol	Parameter	Rating	Unit
V <sub>CC</sub>	VCC Pin Supply Voltage (VCC to GND)	-0.3 to 20	V
I <sub>OUT</sub>	Output Pin Maximum Output Current	1	A
V <sub>OUT</sub>	Output Pin Output Voltage	-0.3 to 20	V
I <sub>HB</sub>	HB Pin Maximum Output Current	10	mA
	1/2FG Pin Output Voltage	-0.3 to V <sub>CC</sub>	V
I <sub>FG</sub>	1/2FG Pin Maximum Output Sink Current	10	mA
V <sub>PWM</sub>	PWM Pin Supply Voltage	-0.3 to 20	V
T <sub>J</sub>	Junction Temperature	-40 to 150	°C
T <sub>STG</sub>	Storage Temperature	-65 to 150	°C
T <sub>SDR</sub>	Maximum Lead Soldering Temperature (10 Seconds)	260	°C

Note1: Stresses beyond those listed under "absolute maximum ratings" may cause permanent damage to the device. These are stress ratings only and functional operation of the device at these or any other conditions beyond those indicated under "recommended operating conditions" is not implied. Exposure to absolute maximum rating conditions for extended periods may affect device reliability

## Thermal Characteristics

Symbol	Parameter	Typical Value	Unit	
R <sub>TH,JA</sub>	Thermal Resistance-Junction to Ambient <sup>(Note 2)</sup>	MSOP-10 SOP-10	208 147	°C/W
P <sub>D</sub>	Power Dissipation, T <sub>A</sub> =25°C	MSOP-10 SOP-10	0.6 0.85	W

Note 2: R<sub>TH,JA</sub> is measured with the component mounted on a high effective thermal conductivity test board in free air.

**Recommended Operation Conditions** (Note 3)

Symbol	Parameter	Range	Unit
V <sub>CC</sub>	VCC Pin Supply Voltage Range	2.2 to 17	V
V <sub>HALL</sub>	Hall Input Voltage Range	0 to 5	V
T <sub>A</sub>	Ambient Temperature	-40 to 110	°C
T <sub>J</sub>	Junction Temperature	-40 to 125	°C

Note 3: Refer to the typical application circuit.

**Electrical Characteristics** (V<sub>CC</sub>=12V, T<sub>A</sub>= 25 °C. unless otherwise specified)

Symbol	Parameter	Test Conditions	APX9275A			Unit
			Min	Typ	Max	
<b>SUPPLY CURRENT</b>						
V <sub>HB</sub>	HB Pin Output Voltage	I <sub>HB</sub> = 5mA	1.2	1.3	1.4	V
I <sub>CC1</sub>	Operating Current	Rotation Mode	-	5	8	mA
I <sub>CC2</sub>		Lock Protection Mode	-	3	5	
I <sub>CC3</sub>		Standby Mode (PWM 0 duty)	-	3	5	
<b>LOCK PROTECTION</b>						
T <sub>ON</sub>	Lock Detection On Time		0.35	0.5	0.65	sec
T <sub>OFF</sub>	Lock Detection Off Time		3.5	5	6.5	sec
<b>OUTPUT DRIVERS</b>						
V <sub>O</sub>	Output Driver Saturation Voltage	I <sub>OUT</sub> = 400mA, Upper and Lower total	-	0.4	0.5	V
V <sub>FG</sub>	1/2FG Pin Low Voltage	I <sub>FG</sub> = 5mA	-	0.2	0.4	V
I <sub>FG</sub> L	1/2FG Pin Leakage Current	V <sub>FG</sub> = 12V	-	<0.1	1	µA
G <sub>IO</sub>	Input - Output Gain	V <sub>OUT</sub> /V <sub>IN+</sub> -V <sub>IN-</sub>	51	52	53	dB
<b>PWM CONTROL</b>						
V <sub>PWMH</sub>	PWM Input High Level Voltage		2.5		V <sub>CC</sub> +0.3	V
V <sub>PWML</sub>	PWM Input Low Level Voltage		-0.3		0.8	V
F <sub>PWM</sub>	PWM Input Frequency		1		50	kHz
T <sub>QS</sub>	Quick Start Enable Time			66.5	90	ms
DST	Start Up PWM Duty	F <sub>PWM</sub> =25KHz	2	6	10	%
		F <sub>PWM</sub> =50KHz	4	12	20	
<b>HALL SENSITIVITY</b>						
V <sub>HOF</sub> S	Hall Input Offset Voltage		-	-	+6	mV
V <sub>HYS</sub>	Input Hysteresis Voltage		±5	±10	±15	mV
<b>PROTECTION</b>						
I <sub>LIM</sub>	Internal Current Limit		-	1000	-	mA
<b>THERMAL SHUTDOWN</b>						
OTS	Over Temperature Shutdown Threshold		-	165	-	°C
	Over Temperature Shutdown Hysteresis		-	30	-	°C

### Typical Operating Characteristics

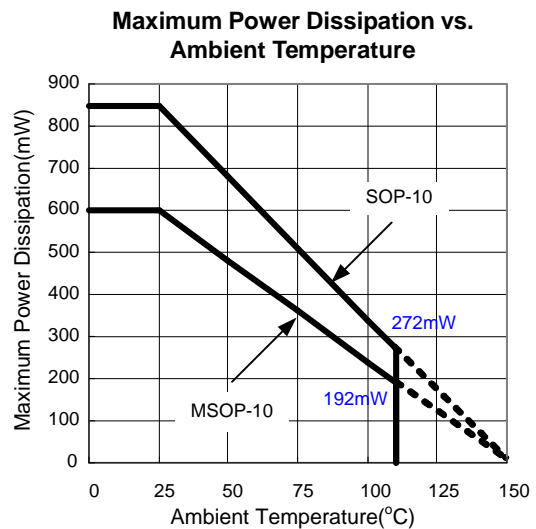
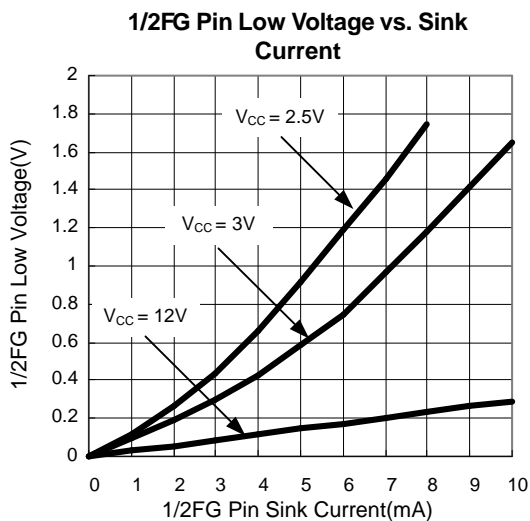
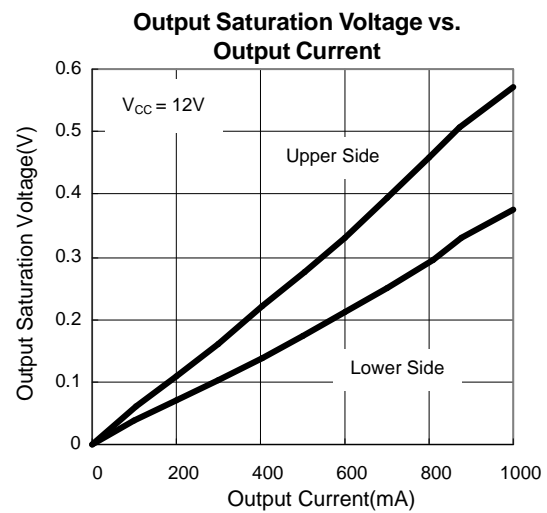
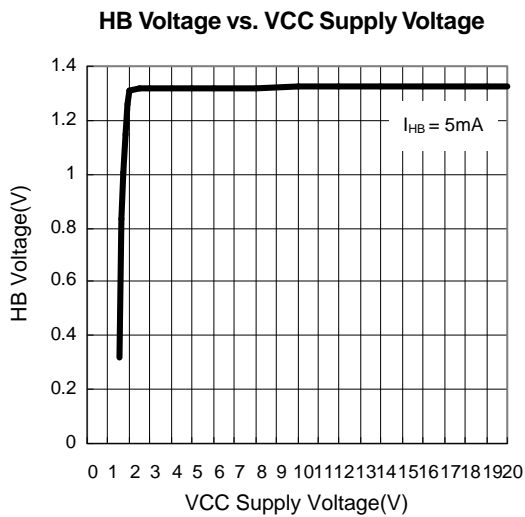
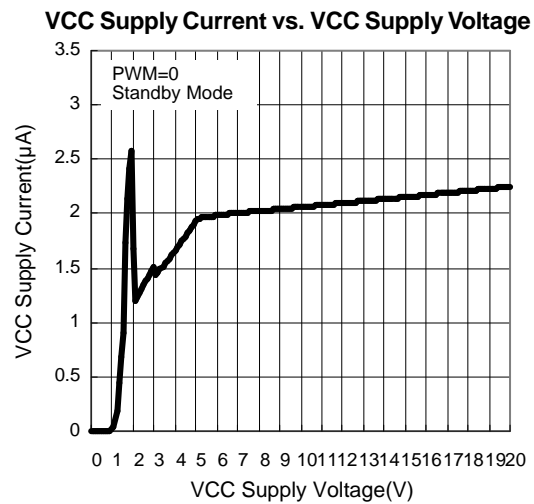
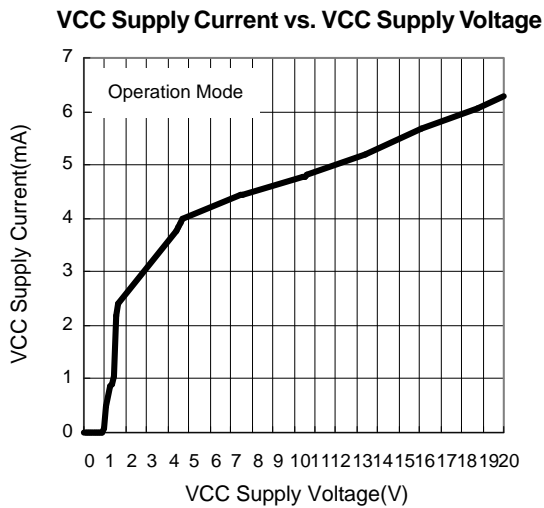

## Pin Description

PIN		Function
NO.	NAME	
1	OUT2	H-bridge output connection.
2	VCC	Supply Voltage.
3	IN+	Hall Input +. Connect to hall element positive output.
4	HB	Hall Bias. This is a 1.3V constant-voltage output for hall element bias.
5	IN-	Hall Input -. Connect to hall element negative output.
6	NC	No connection.
7	1/2FG	Rotation Speed Output. This is an open-drain output.
8	PWM	PWM Signal Input Terminal. Please let it be floating when use type A or type B to control speed.
9	OUT1	H-bridge output connection.
10	GND	Power GND.

## Block Diagram

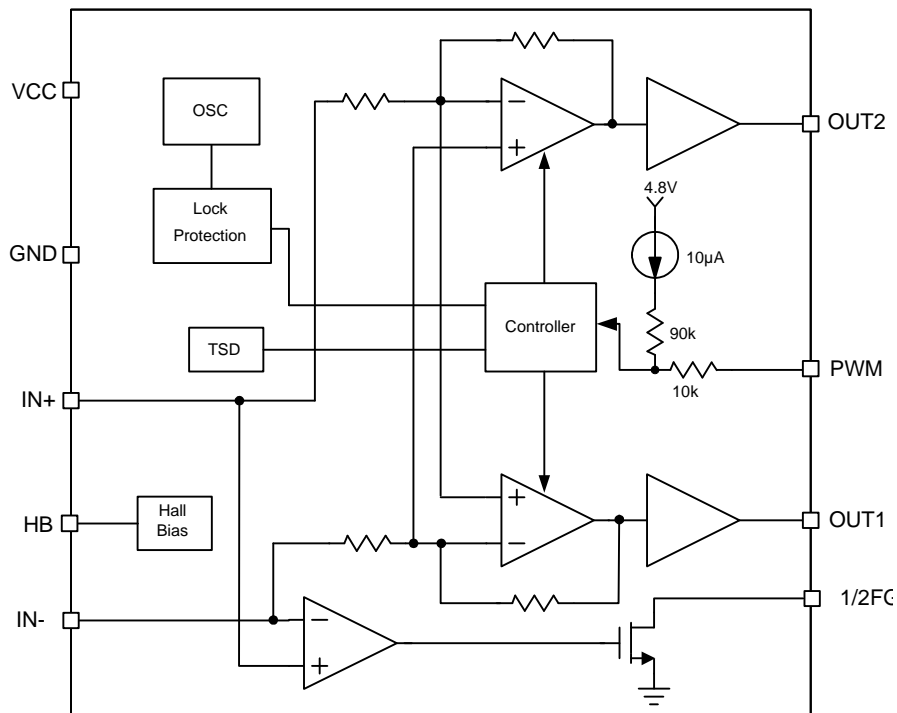

Typical Application Circuit

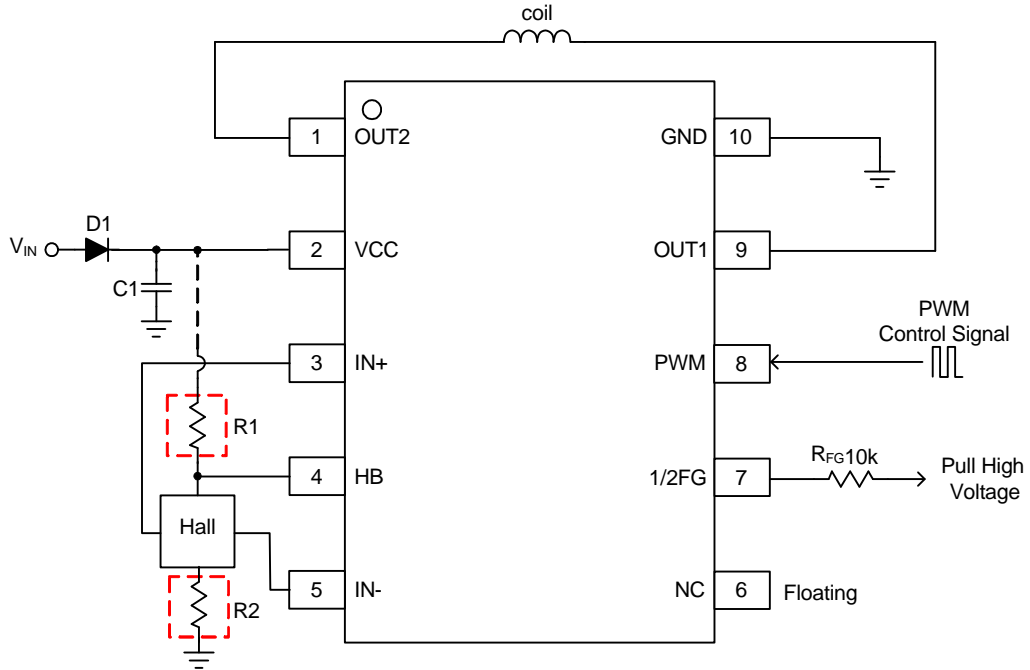

Note: R1 is optional to reduce the power consumption from HB supply current.  
 R2 is optional to adjust the amplitude of hall signal.

## Function Description

### Lockup Protection and Automatic Restart

The APX9275A provides the lockup protection and automatic restart functions for preventing the coil burn-out when the fan is locked. This IC has an internal counter to determine the shutdown time ( $T_{OFF}$ ) and restart time ( $T_{ON}$ ). During shutdown time, the output drivers keep turn off for 5 seconds and then enter the restart time. During the restart time, one output is high and the other is low, which makes a torque for fan rotation. The restart time has 0.5 second. If the locked condition is not removed, the shutdown/restart process will be recurred until the locked condition is released (see Fig1. Lockup/Auto Restart Waveform).

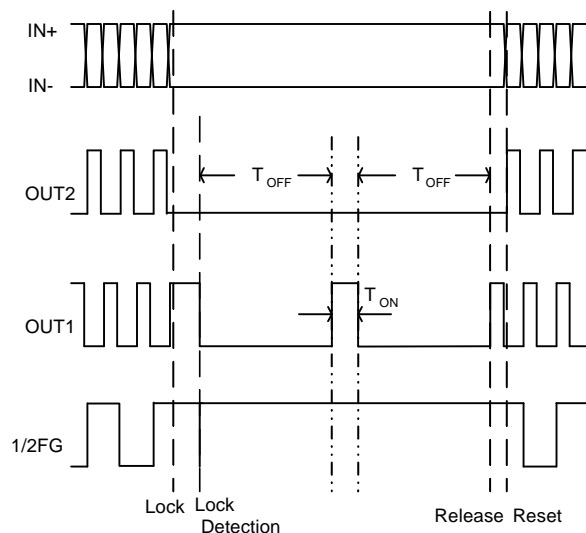

Figure 1. Lockup /Auto Restart Waveform

### Quick Start and Standby mode

This IC would enter standby mode when the PWM input keeps low level for more than 66.5ms (typ.). In standby mode, it will shut down amplifier and FG. Thus, the supply current is around 3mA. In standby mode, the lock protection function doesn't work, therefore, starting fan is unobstructed when releasing standby mode.

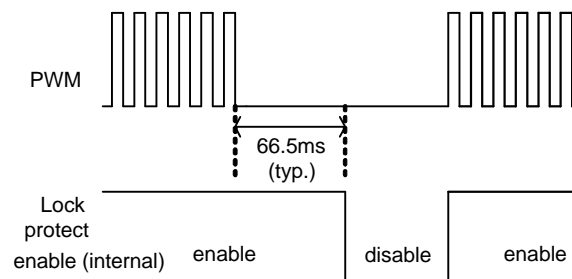

Figure 2. Quick Start Waveform

### Output Drivers

All four drivers in the bridge output are designed for single phase full wave motor driver for fan motor. The linear output architecture is used as output driver.

### Frequency Generator Function

The 1/2FG pin is an open drain output, connecting a pull up resistor to a high level voltage for the frequency generator function. Open the terminal when not in using.

### Thermal Protection

The APX9275A has thermal protection function, when internal junction temperature reaches 165°C, the output devices will be switched off. When the IC's junction temperature cools by 30°C, the thermal sensor will turn the output devices on again, resulting in a pulsed output during continuous thermal protection.

**Truth Table**

Input			Output			Mode
IN-	IN+	PWM	OUT1	OUT2	1/2FG	
L	H	H	H	L	L/OFF	Normal Operation Mode
H	L		L	H	L/OFF	
H	L	L	L	L	L/OFF	
L	H		L	L	L/OFF	
L	H	-	L	L	OFF	Lock Protection Mode
H	L		L	L	OFF	
-	-	L	OFF	OFF	OFF	Standby Mode



## Application Information

### Input Protection Diode & Capacitor

It should be added a protection diode (D1) to protect the damage from the power reverse connection. However, the protection diode will cause a voltage drop on the supply voltage. The current rating of the diode must be larger than the maximum output current. For the noise reduction purpose, there is a least 1μF capacitor (C1) recommended connecting between VCC and GND (see Typical Application Circuit).

### Hall Input & Output

The output signals of this IC are the amplification of hall input signals, therefore, the output signals depend on hall input. When the hall input signals are small, the output signals become gentle. Oppositely, the input signals are large, the output signals become steep (see Fig4. Different of output signal depending on the shape of hall input signal). The input/output gain is 52dB (typ.). Thus, please adjust the amplitude of hall input to meet the adequate output voltage.

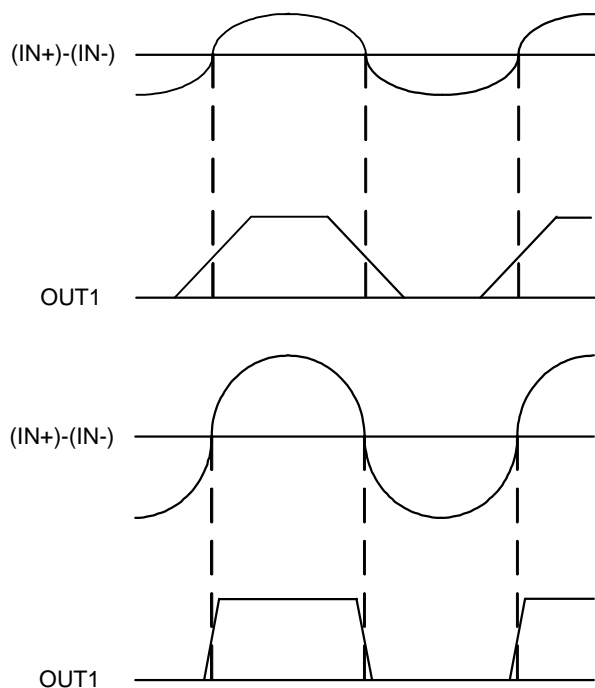

Figure 3. Different of output original depending on the shape of hall input signal

### FG Resistor

The value of the FG resistor could be decided by the following equation:

$$R_{FG} = \frac{V_{CC} - V_{FG}}{I_{FG}}$$

For example:

$$V_{CC} = 5V, I_{FG} = 5mA, V_{FG} = 0.2V, R_{FG} = 0.96k\Omega$$

The value of resistor in the range from 1kΩ to 10kΩ is recommended.

Package Information

MSOP-10

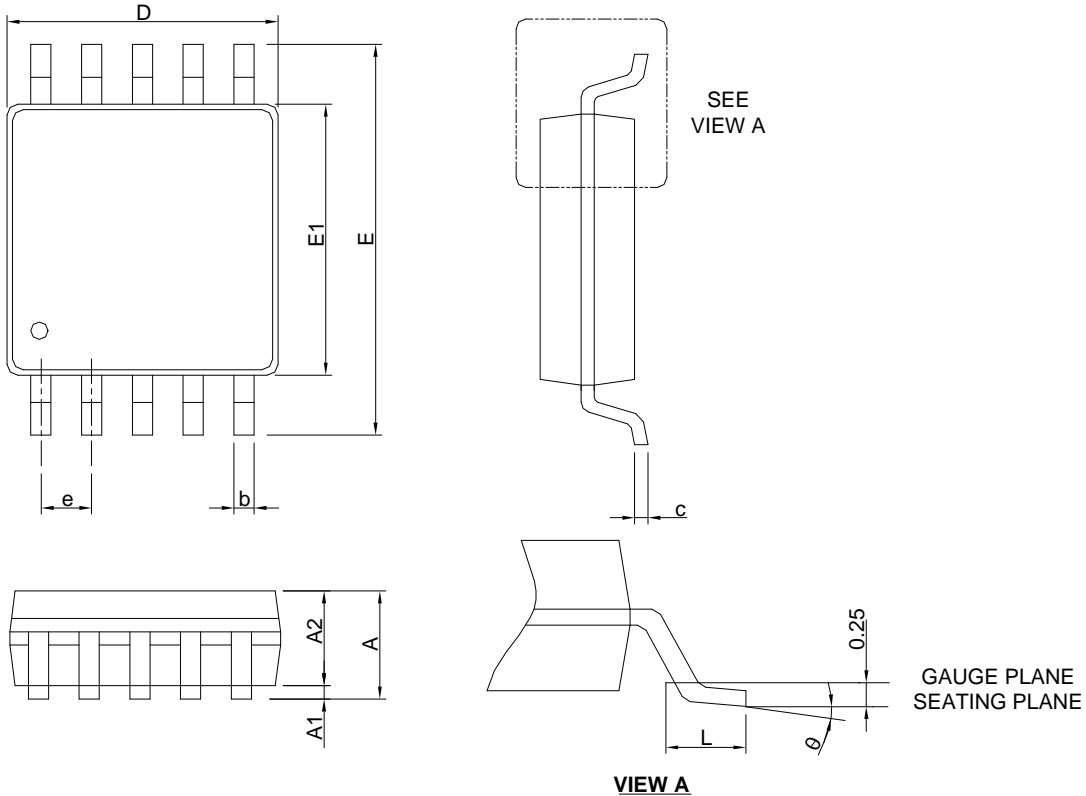

SYMBOL	MSOP-10			
	MILLIMETERS		INCHES	
	MIN.	MAX.	MIN.	MAX.
A		1.10		0.043
A1	0.00	0.15	0.000	0.006
A2	0.75	0.95	0.030	0.037
b	0.17	0.33	0.007	0.013
c	0.08	0.23	0.003	0.009
D	2.90	3.10	0.114	0.122
E	4.70	5.10	0.185	0.201
E1	2.90	3.10	0.114	0.122
e	0.50 BSC		0.020 BSC	
L	0.40	0.80	0.016	0.031
theta	0°	8°	0°	8°

- Note: 1. Follow JEDEC MO-187 BA.  
 2. Dimension " D " does not include mold flash, protrusions or gate burrs. Mold flash, protrusion or gate burrs shall not exceed 0.15 mm or 0.006 inches.  
 3. Dimension " E1 " does not include inter-lead flash or protrusions. Inter-lead flash and protrusions shall not exceed 6 mil per side.

Package Information

SOP-10

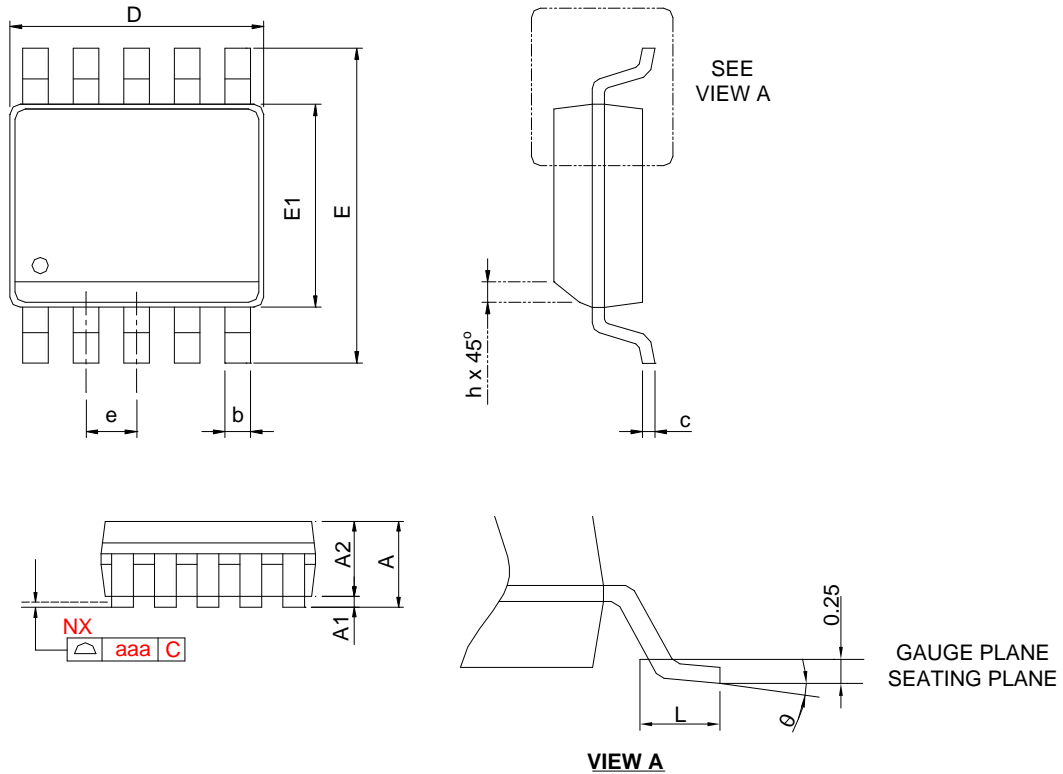

SYMBOL	SOP-10			
	MILLIMETERS		INCHES	
	MIN.	MAX.	MIN.	MAX.
A		1.75		0.069
A1	0.10	0.25	0.004	0.010
A2	1.25		0.049	
b	0.30	0.45	0.012	0.018
c	0.17	0.25	0.007	0.010
D	4.80	5.00	0.189	0.197
E	5.80	6.20	0.228	0.244
E1	3.80	4.00	0.150	0.157
e	1.00 BSC		0.039 BSC	
h	0.25	0.50	0.010	0.020
L	0.40	1.27	0.016	0.050
θ	0°	8°	0°	8°
aaa	0.10		0.004	

- Note:1. Dimension “ D ” does not include mold flash, protrusions or gate burrs.  
 Mold flash, protrusion or gate burrs shall not exceed 10 mil per side.  
 2. Dimension “ E ” does not include inter-lead flash or protrusions.  
 Inter-lead flash and protrusions shall not exceed 10 mil per side.

### Carrier Tape & Reel Dimensions

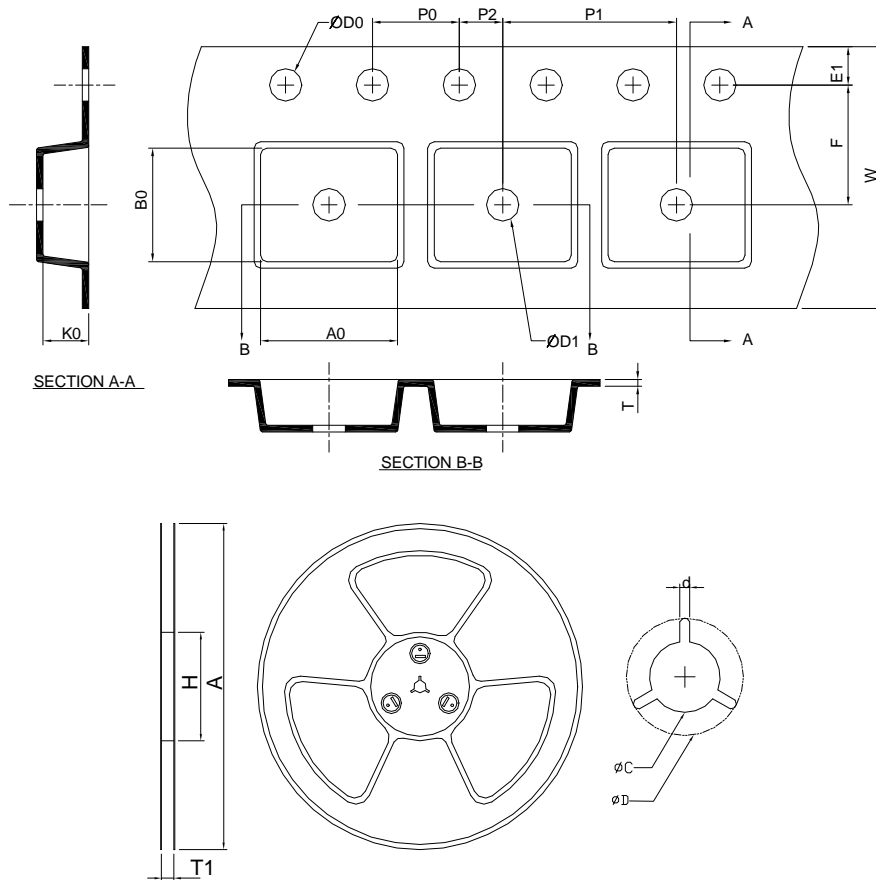

Application	A	H	T1	C	d	D	W	E1	F
SOP-10	330.0 ±2.00	50 MIN.	12.4+2.00 -0.00	13.0+0.50 -0.20	1.5 MIN.	20.2 MIN.	12.0 ±0.30	1.75 ±0.10	5.5 ±0.05
	P0	P1	P2	D0	D1	T	A0	B0	K0
	4.0 ±0.10	8.0 ±0.10	2.0 ±0.05	1.5+0.10 -0.00	1.5 MIN.	0.6+0.00 -0.40	6.40 ±0.20	5.20 ±0.20	2.10 ±0.20
Application	A	H	T1	C	d	D	W	E1	F
MSOP-10	330.0 ±2.00	50 MIN.	12.4+2.00 -0.00	13.0+0.50 -0.20	1.5 MIN.	20.2 MIN.	12.0 ±0.30	1.75 ±0.10	5.5 ±0.05
	P0	P1	P2	D0	D1	T	A0	B0	K0
	4.00 ±0.10	8.00 ±0.10	2.00 ±0.05	1.5+0.10 -0.00	1.5 MIN.	0.6+0.00 -0.40	5.30 ±0.20	3.30 ±0.20	1.40 ±0.20

(mm)

### Devices Per Unit

Package Type	Unit	Quantity
SOP-10	Tape & Reel	2500
MSOP-10	Tape & Reel	3000

## Taping Direction Information

MSOP-10

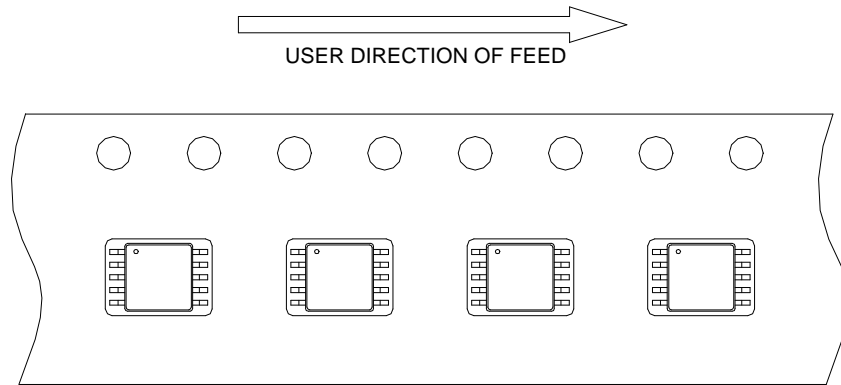

SOP-10

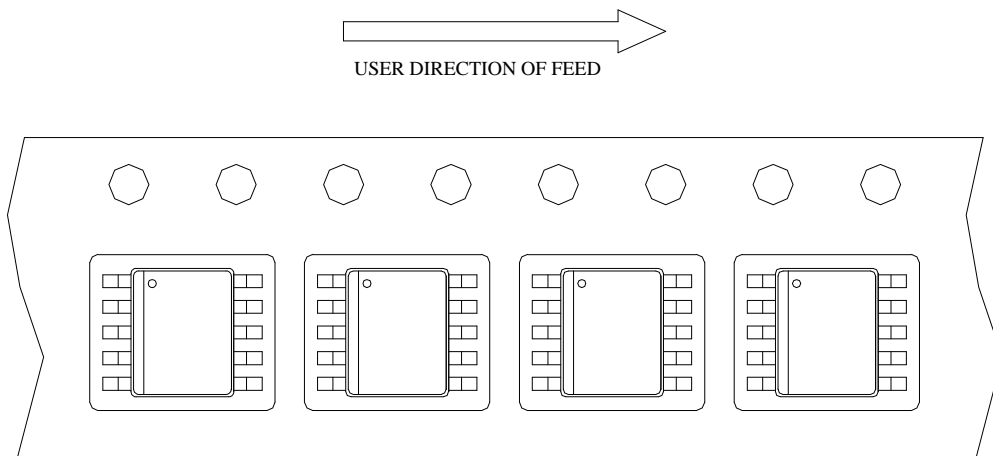

Classification Profile

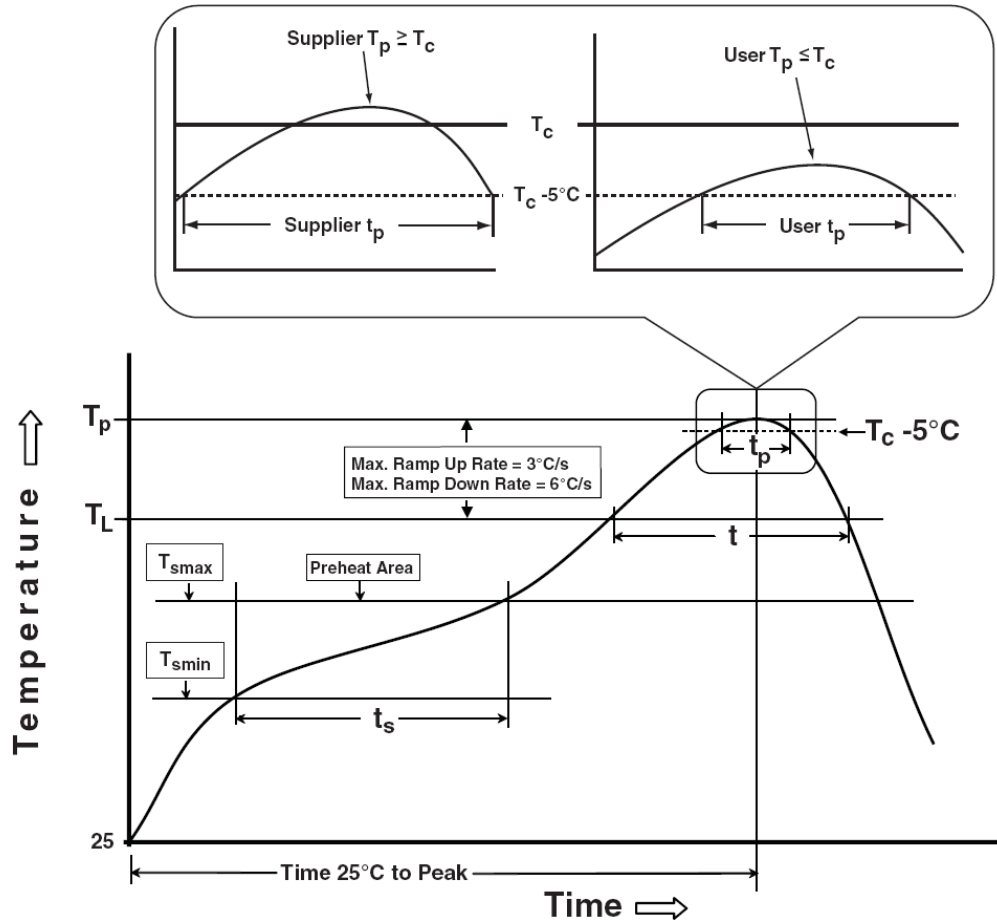

### Classification Reflow Profiles

Profile Feature	Sn-Pb Eutectic Assembly	Pb-Free Assembly
<b>Preheat &amp; Soak</b> Temperature min ( $T_{smin}$ ) Temperature max ( $T_{smax}$ ) Time ( $T_{smin}$ to $T_{smax}$ ) ( $t_s$ )	100 °C 150 °C 60-120 seconds	150 °C 200 °C 60-120 seconds
Average ramp-up rate ( $T_{smax}$ to $T_p$ )	3 °C/second max.	3°C/second max.
Liquidous temperature ( $T_L$ ) Time at liquidous ( $t_L$ )	183 °C 60-150 seconds	217 °C 60-150 seconds
Peak package body Temperature ( $T_p$ )*	See Classification Temp in table 1	See Classification Temp in table 2
Time ( $t_p$ )** within 5°C of the specified classification temperature ( $T_c$ )	20** seconds	30** seconds
Average ramp-down rate ( $T_p$ to $T_{smax}$ )	6 °C/second max.	6 °C/second max.
Time 25°C to peak temperature	6 minutes max.	8 minutes max.
* Tolerance for peak profile Temperature ( $T_p$ ) is defined as a supplier minimum and a user maximum. ** Tolerance for time at peak profile temperature ( $t_p$ ) is defined as a supplier minimum and a user maximum.		

Table 1. SnPb Eutectic Process – Classification Temperatures ( $T_c$ )

Package Thickness	Volume mm <sup>3</sup> <350	Volume mm <sup>3</sup> ≥350
<2.5 mm	235 °C	220 °C
≥2.5 mm	220 °C	220 °C

Table 2. Pb-free Process – Classification Temperatures ( $T_c$ )

Package Thickness	Volume mm <sup>3</sup> <350	Volume mm <sup>3</sup> 350-2000	Volume mm <sup>3</sup> >2000
<1.6 mm	260 °C	260 °C	260 °C
1.6 mm – 2.5 mm	260 °C	250 °C	245 °C
≥2.5 mm	250 °C	245 °C	245 °C

### Reliability Test Program

Test item	Method	Description
SOLDERABILITY	JESD-22, B102	5 Sec, 245°C
HOLT	JESD-22, A108	1000 Hrs, Bias @ $T_j=125^\circ\text{C}$
PCT	JESD-22, A102	168 Hrs, 100%RH, 2atm, 121°C
TCT	JESD-22, A104	500 Cycles, -65°C~150°C
HBM	MIL-STD-883-3015.7	VHBM 2KV
MM	JESD-22, A115	VMM 200V
Latch-Up	JESD 78	10ms, 1 <sub>tr</sub> 100mA

---

## Customer Service

### **Anpec Electronics Corp.**

Head Office :

No.6, Dusing 1st Road, SBIP,  
Hsin-Chu, Taiwan  
Tel : 886-3-5642000  
Fax : 886-3-5642050

Taipei Branch :

2F, No. 11, Lane 218, Sec 2 Jhongsing Rd.,  
Sindian City, Taipei County 23146, Taiwan  
Tel : 886-2-2910-3838  
Fax : 886-2-2917-3838