



CMT4501

Bluetooth Low Energy (BLE) System on Chip

Key Features

- ARM® Cortex™-M0 32-bit processor
- Memory
 - 512/256KB in-system flash memory
 - 128KB ROM
 - 138KB SRAM, all programmable retention in sleep mode
 - 8-channel DMA
- 33/19 general purpose I/O pins
 - All pins can be configured as serial interface and programmable IO MUX function mapping
 - All pins can be configured for wake-up
 - 18 pins for triggering interrupt
 - 3 quadrature decoder(QDEC)
 - 6-channel PWM
 - 4-channel I2S
 - 2-channel PDM
 - 2-channel I2C
 - 2-channel SPI
 - 1-channel UART
 - JTAG
- 8-channel 12bit ADC with analog PGA
- 4-channel 32bit timer, one watchdog timer
- Real timer counter (RTC)
- Power, clock, reset controller
- Flexible power management
 - Supply voltage range 1.8V to 3.6V
 - Embedded buck DC-DC
 - Embedded LDOs
 - Battery monitor: Supports low battery detection
 - 2µA @ Sleep Mode with 32KHz RTC
 - 0.7µA @ OFF Mode (IO wake up only)
- 2.4 GHz transceiver
 - Compliant to Bluetooth 4.0, ETSI EN 300 328 and EN 300 440 Class 2 (Europe), FCC CFR47 Part 15 (US) and ARIB STD-T66 (Japan)
 - Sensitivity:
 - 97dBm@BLE 1Mbps data rate
 - 103dBm@BLE 125Kbps data rate
 - TX Power -20 to +10dBm in 3dB steps
 - Receiver: 8mA @sensitivity level
 - Transmitter: 8mA @0dBm TX power
 - Single-pin antenna: no RF matching or RX/TX switching required
 - RSSI (1dB resolution)
- RC oscillator hardware calibrations
 - 32KHz RC oscillator automatic calibration
 - 32MHz RC oscillator automatic calibration
- AES-128 encryption hardware
 - AES-ECB
 - AES-CCM
- Link layer hardware
 - Automatic packet assembly
 - Automatic packet detection and validation
 - Auto Re-transmit
 - Auto ACK
 - Hardware Address Matching
 - Random number generator
- Operating temperature: -40 °C~125°C
- RoHS Package: QFN32
- Applications: wearables, beacons, appliances, home and building, health and medical, sports and fitness, industrial and manufacturing, retail and payment, security, data transmission, remote control, PC/mobile/TV peripherals, internet of things (IoT)

Liability Disclaimer

CMOSTEK Inc. reserves the right to make changes without further notice to the product to improve reliability, function or design. CMOSTEK Inc. does not assume any liability arising out of the application or use of any product or circuits described herein.

Life Support Applications

CMOSTEK Semiconductor's products are not designed for use in life support appliances, devices, or systems where malfunction of these products can reasonably be expected to result in personal injury. CMOSTEK Inc. customers using or selling these products for use in such applications do so at their own risk and agree to fully indemnify CMOSTEK Inc. for any damages resulting from such improper use or sale.

Table of Contents

1	Introduction	5
2	Product Overview.....	6
2.1	Block Diagram	6
2.2	Pin Assignments and Functions	7
2.2.1	CMT4501 (QFN32)	7
2.2.1.1	Pin Assignment.....	7
2.2.1.2	Pin Functions.....	8
3	System Blocks.....	9
3.1	CPU.....	9
3.2	Memory	9
3.2.1	ROM 11	
3.2.2	SRAM11	
3.2.3	FLASH11	
3.2.4	Memory Address Mapping.....	11
3.3	Boot and Execution Modes	11
3.3.1	Mirror Mode	12
3.3.2	FLASH Mode.....	12
3.3.3	Boot loader	12
3.4	Power, Clock and Reset (PCR)	13
3.5	Power Management (POWER)	13
3.6	Low Power Features	15
3.6.1	Operation and Sleep States.....	15
3.6.1.1	Normal State	15
3.6.1.2	Clock Gate State	15
3.6.1.3	System Sleep State	15
3.6.1.4	System Off State.....	15
3.6.2	State Transition	15
3.6.2.1	Entering Clock Gate State and Wake-up	15
3.6.2.2	Entering Sleep/off States and Wake-up	15
3.7	Interrupts.....	15
3.8	Clock Management (CLOCK).....	17
3.9	IOMUX	18
3.10	GPIO	29

4	Peripheral Blocks	33
4.1	2.4GHz Radio	33
4.2	Timer/Counters (TIMER)	33
4.3	Real Time Counter (RTC)	36
4.4	AES-ECB Encryption (ECB)	38
4.5	Random Number Generator (RNG)	40
4.6	Watchdog Timer (WDT)	40
4.7	SPI (SPI)	40
4.8	I2C (I2c0, I2c1 Two Independent Instances)	45
4.9	I2S	55
4.10	UART (UART)	60
4.11	Pulse Width Modulation (PWM)	70
4.12	Quadrature Decoder (QDEC)	78
4.13	Key Scan (KSCAN)	82
4.14	Analog to Digital Converter (ADC) with Programmable Gain Amplifier (PGA)	84
4.14.1	PGA Path	84
4.14.2	ADC Path	85
4.14.3	ADC Channel <3:0> Connectivity	88
5	Absolute Maximum Ratings	89
6	Operating Conditions	90
7	Radio Transceiver	90
7.1	Radio Current Consumption	90
7.2	Transmitter Specification	90
7.3	Receiver Specification	90
7.3.1	RX BLE 1Mbps GFSK	91
7.3.2	RX BLE 2Mbps GFSK	91
7.3.3	RX 500Kbps GFSK	92
7.3.4	RX 125Kbps GFSK	92
7.4	RSSI Specifications	93
8	Glossary	94
12	Sample Application and Layout Guide	96
13	Contact Details	102

1 Introduction

CMT4501 is a System on Chip (SoC) for Bluetooth® low energy applications. CMT4501 has 32-bit ARM® Cortex™-M0 CPU with 138KSRAM/Retention SRAM and an ultra-low power, high performance, multi-mode radio. CMT4501 can support BLE with security, application and over-the-air download update. Serial peripheral IO and integrated application IP enables customer product to be built with minimum bill-of-material (BOM) cost.

2 Product Overview

2.1 Block Diagram

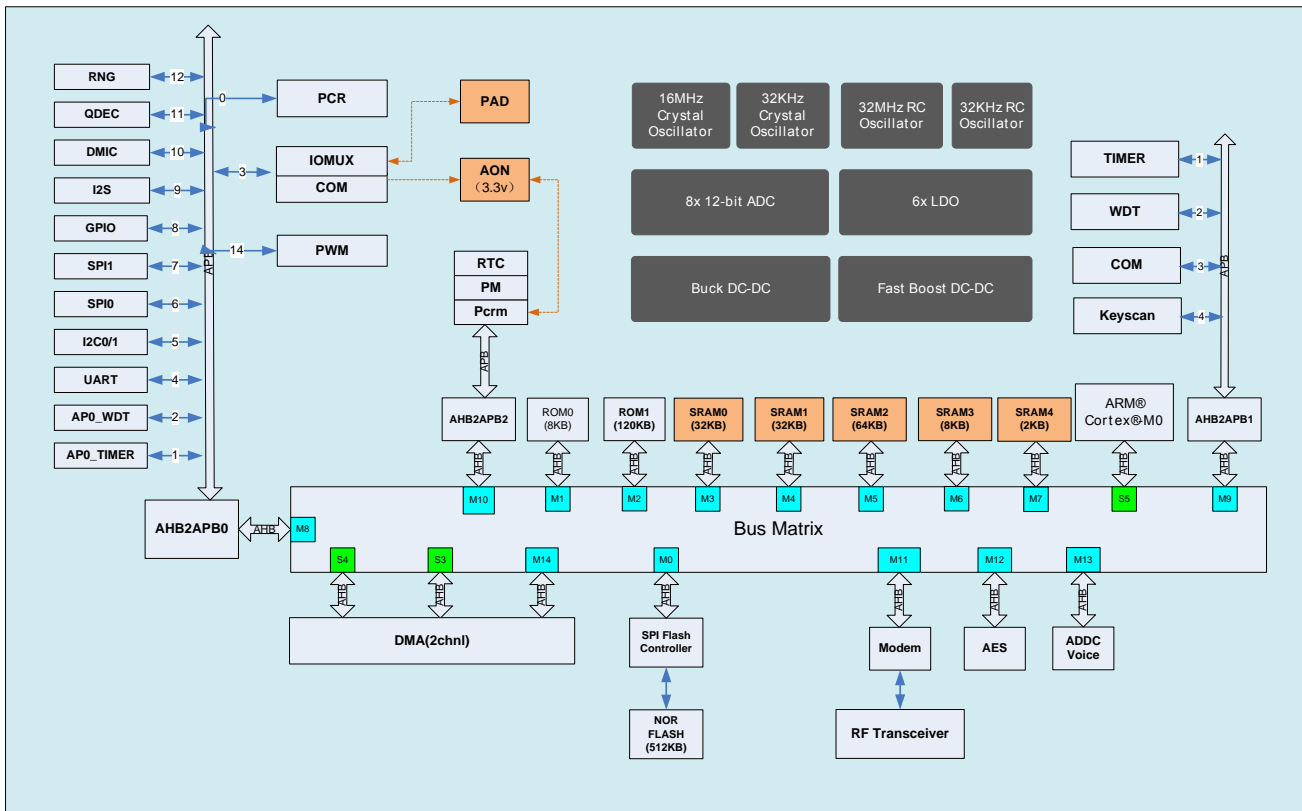

Figure 1: CMT4501 block diagram

2.2 Pin Assignments and Functions

This section describes the pin assignment and the pin functions for the different package types.

2.2.1 CMT4501 (QFN32)

2.2.1.1 Pin Assignment

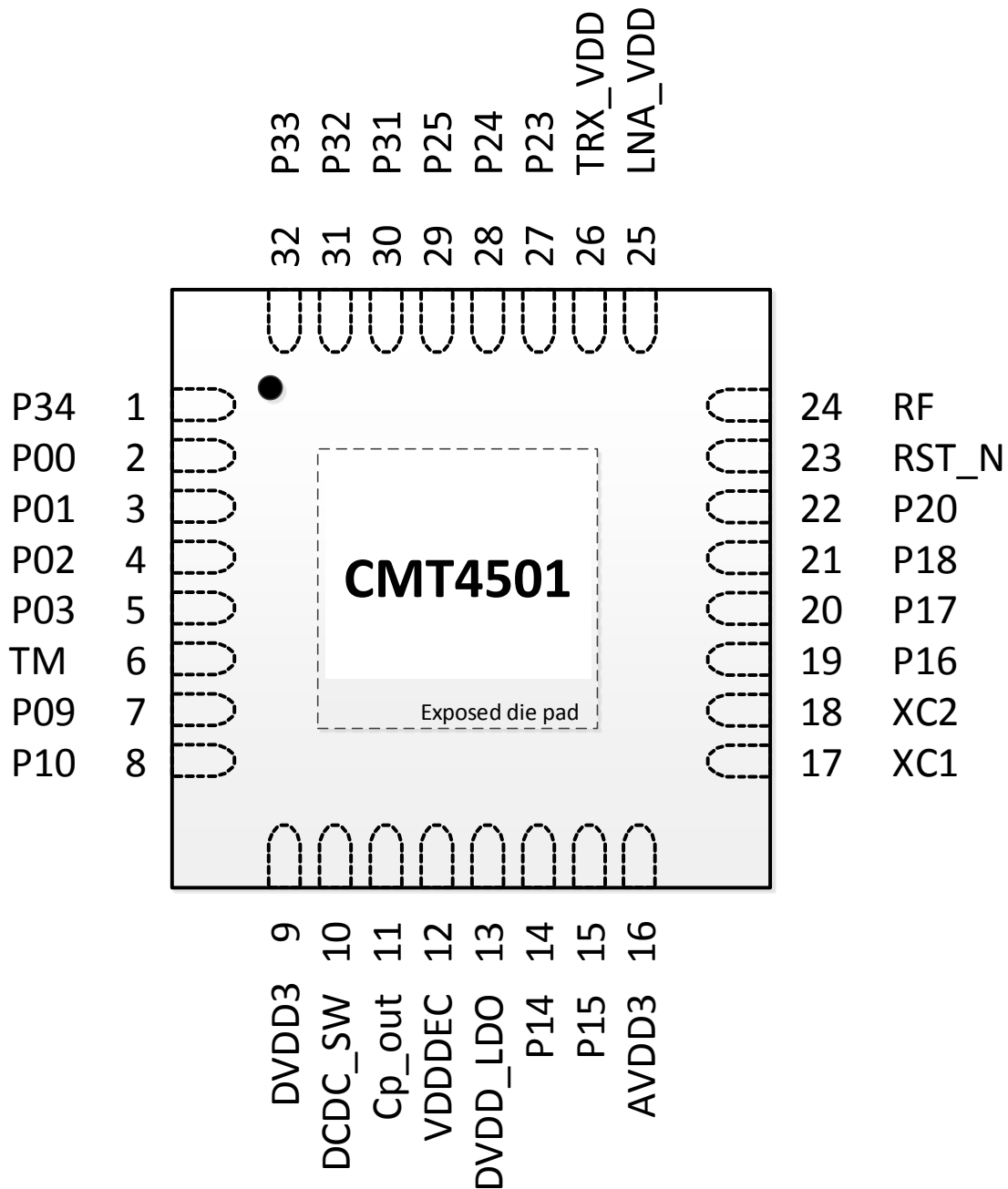

Figure 3: Pin assignment - CMT4501 QFN32 package

2.2.1.2 Pin Functions

Pin	Pin name	Description
1	P34	all functions configurable *Note: Not support interrupt and ADC function
2	P00	all functions configurable/ JTAG_TDO *Note: Not support ADC function
3	P01	all functions configurable/ JTAG_TDO *Note: Not support ADC function
4	P02	all functions configurable/ JTAG_TDO *Note: Not support ADC function
5	P03	all functions configurable/ JTAG_TDO *Note: Not support ADC function
6	TM	Test_Mode
7	P09	all functions configurable/ JTAG_TDO *Note: Not support ADC function
8	P10	all functions configurable/ JTAG_TDO *Note: Not support ADC function
9	DVDD3	3V power supply for digital IO, DCDC, Charge pump
10	DCDC_SW	Buck dcdc output
11	cp_out	charge pump output
12	VDDDEC	1.2V VDD_CORE, digital LDO output
13	DVDD_LDO	digital LDO input
14	P14	all functions configurable/AIO<3>
15	P15	all functions configurable/AIO<4>
16	AVDD3	3V power supply for analog IO, bg, rcosc, etc
17	XC1	16M crystal input
18	XC2	16M crystal output
19	P16	all functions configurable/AIO<5>/32K crystal input
20	P17	all functions configurable/AIO<6>/32k crystal output
21	P18	all functions configurable/ JTAG_TDO *Note: Not support interrupt function
22	P20	all functions configurable/AIO<9>/Micphone bias output
23	RST_N	reset pin
24	RF	RF antenna
25	LNA_VDD	LNA_VDD
26	TRX_VDD	TRX_VDD
27	P23	all functions configurable *Note: Not support interrupt and ADC function
28	P24	all functions configurable/test_mode_select[0] *Note: Not support interrupt and ADC function
29	P25	all functions configurable/test_mode_select[1] *Note: Not support interrupt and ADC function
30	P31	all functions configurable *Note: Not support interrupt and ADC function
31	P32	all functions configurable *Note: Not support interrupt and ADC function
32	P33	all functions configurable *Note: Not support interrupt and ADC function

Table 2: Pin functions CMT4501 QFN32 package

3 System Blocks

The system block diagram of CMT4501 is shown in **Figure 1**.

3.1 CPU

The CMT4501 has an ARM Cortex-M0 CPU. The CPU, memories, and all peripherals are connected by AMBA bus fabrics.

The ARM® Cortex™-M0 CPU has a 16-bit instruction set with 32-bit extensions (Thumb-2® technology) that delivers high-density code with a small-memory-footprint. By using a single-cycle 32-bit multiplier, a 3-stage pipeline and a Nested Vector Interrupt Controller (NVIC), the ARM Cortex™-M0 CPU makes program execution simple and highly efficient.

The CPU will play controller role in BLE modem and run all user applications. The following main features are listed below.

- Up to 48Mhz ARM Cortex™-M0 processor core.
 - Low gate count and high energy efficient.
 - ARMv6M architecture, Thumb ISA but no ARM ISA.
 - No cache and no TCM.
 - Up to 32 interrupts embedded NVIC.
 - SysTick timer.
 - Sleep/deep sleep mode.
 - Support low power WFI and WFE
- 4 32-bit general purpose timers and 1 watchdog timer (WDT).
- 120KB ROM for boot and protocol stack.
- 138KB retention SRAM for program and data.
- AHB to APB Bridge for peripherals and registers.
- Clock and reset controller.
- AHB debug access port interface and DAP ROM.
- APB interface to/from BLE modem.
- Dynamic and static clock gating to save power.
- No TRACE.

Some of these features are shared with the AP subsystem.

3.2 Memory

CMT4501 has total 128KB ROM, 138KB SRAM and up to 512KB FLASH. The physical address space of these memories is shown in **Figure4**.

CMT4501 Memory Space

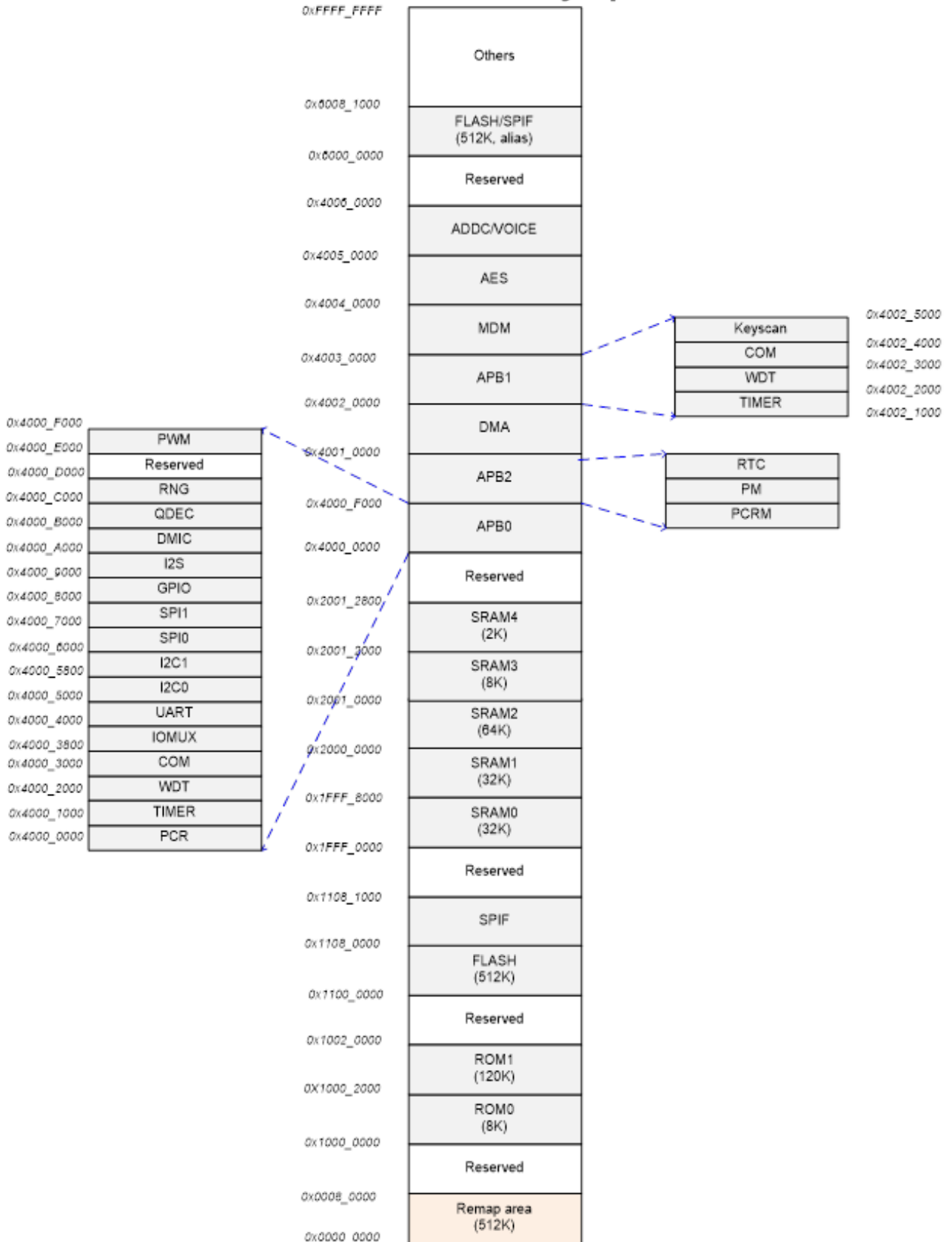

Figure 4: CMT4501 memory space

3.2.1 ROM

CMT4501 has 2 ROMs.

	SIZE	CONTENT
ROM0	8KB	Reserved
ROM1	120KB	Boot ROM for M0. Protocol stack. Common peripheral drivers.

Table 3: List of ROMs

3.2.2 SRAM

CMT4501 has 5 SRAM blocks. All 5 SRAM blocks have retention capability, which can be configured individually. All SRAM blocks can be used to store program or data.

	SIZE	CONTENT
SRAM0	32KB	
SRAM1	32KB	
SRAM2	64KB	
SRAM3	8KB	
SRAM4	2KB	

Table 4: List of SRAMs

3.2.3 FLASH

CMT4501 has FLASH to provide non-volatile program and data storage. The size of the FLASH can be 256KB or 512KB. CMT4501 supports 2-wire reading.

3.2.4 Memory Address Mapping

Name	Size (KB)	Master	Physical Address	CM4 Alias	M0 Remap		
					0	1	2
ROM0	8	M0	1000_0000~1000_1FFF	0x0			
ROM1	120	M0	1000_2000~1001_FFFF		0x0		
RAM0	32	M0	1FFF_0000~1FFF_7FFF				
RAM1	32	M0	1FFF_8000~1FFF_FFFF				
RAM2	64	M0	2000_0000~2000_FFFF			0x0	
RAM3	8	M0	2001_0000~2001_1FFF				
RAM4	2	M0	2001_2000~2001_27FF				
FLASH	512	M0	1100_0000~1107_FFFF				0x0
			6000_0000~6007_FFFF				

Table 5: Memory address mapping

3.3 Boot and Execution Modes

During the boot, the ROM1 is aliased to 0x0 address. The M0 starts to execute the program from the ROM1.

Boot

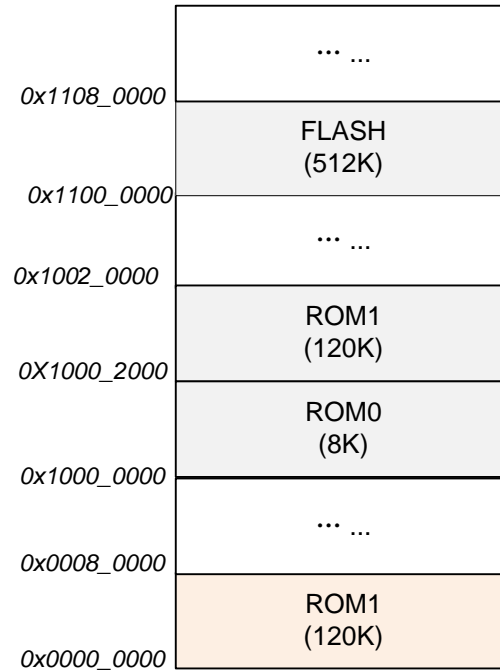

Figure 5: CMT4501 boot mode

3.3.1 Mirror Mode

The mirror mode is not tied to the chip variations. Any chip variation can use mirror mode to execute program. In the mirror mode, the program is copied from the FLASH to the SRAM, then is executed in the SRAM. For the M0 processor, one of the SRAM blocks must be aliased to 0x0 address.

3.3.2 FLASH Mode

The FLASH mode is not tied to the chip variations. Any chip variation can use FLASH mode to execute program. In the FLASH mode, the program is executed in the FLASH. For the M0 processor, the FLASH must be aliased to 0x0 address.

3.3.3 Boot loader

The boot loader in the ROM has the basic structure as shown below. The content in the FLASH should be specifically defined to allow boot loader to identify whether the FLASH content is valid, as shown in the example below. If the FLASH is valid, the ROM boot loader will put the chip in the normal mode and start normal program execution. If the FLASH is not valid, the boot loader will enter FLASH programming mode.

Address	Variable	Content
0	PRODUCT_MODE	Identify the chip mode
4	CODE_BASE	The base address of the code
8	CODE_LEN	The length of the code
C	BOOT_MODE	Identify mirror or FLASH mode

Table 6: Flash content example

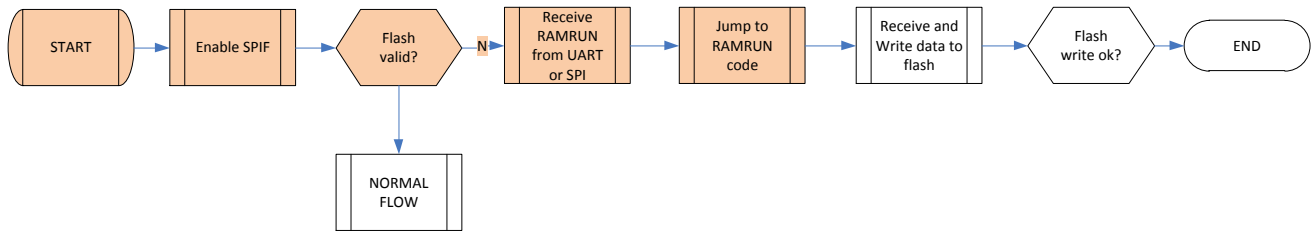

Figure6: Bootloader flow

3.4 Power, Clock and Reset (PCR)

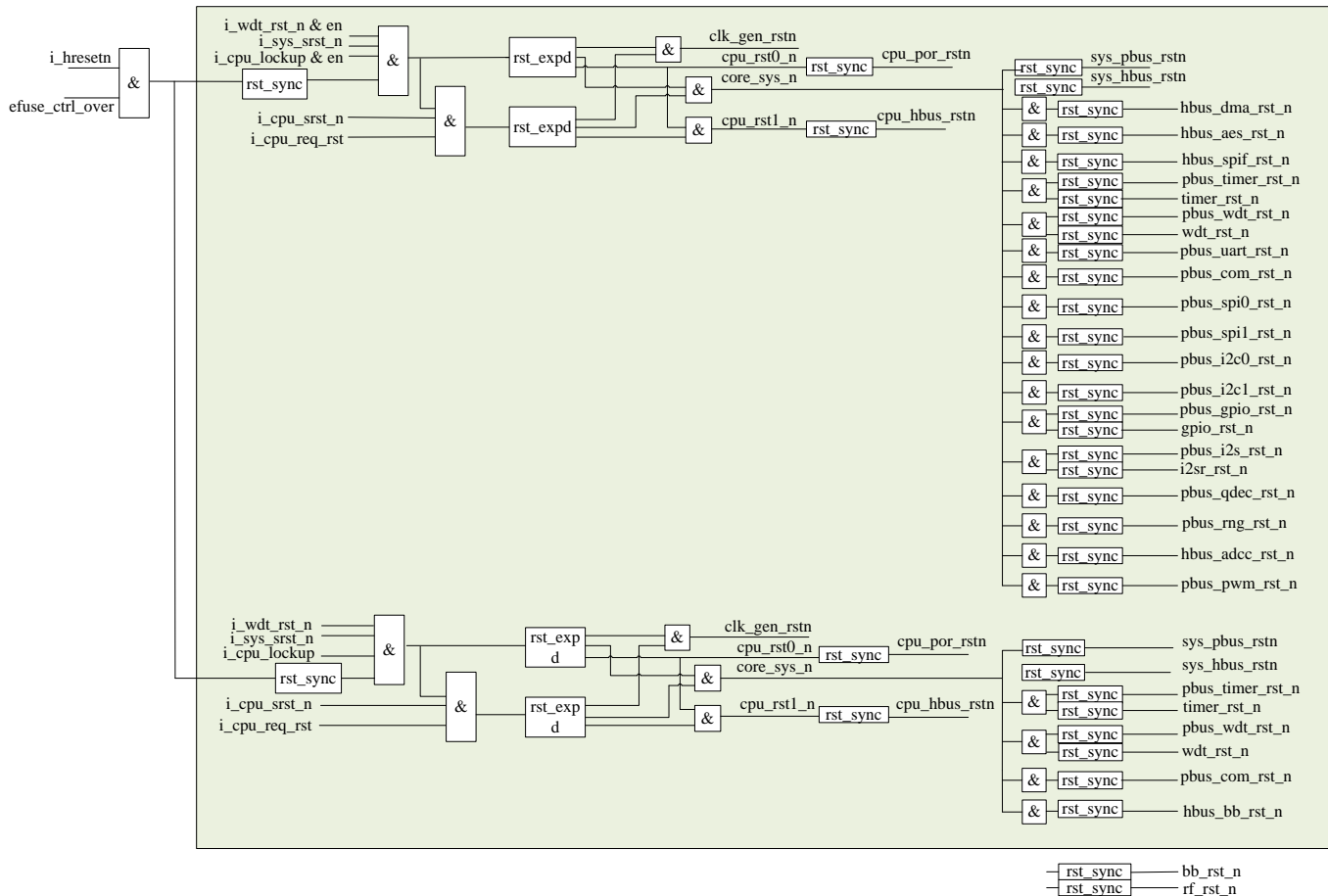

Figure 7: CMT4501 power, clock and reset

3.5 Power Management (POWER)

The power management system is highly flexible with functional blocks such as the CPU, radio transceiver, and peripherals saving separate power state control in addition to the System Sleep mode and OFF modes. When in System Normal mode, all functional blocks will independently be turned on depending on needed application functionality.

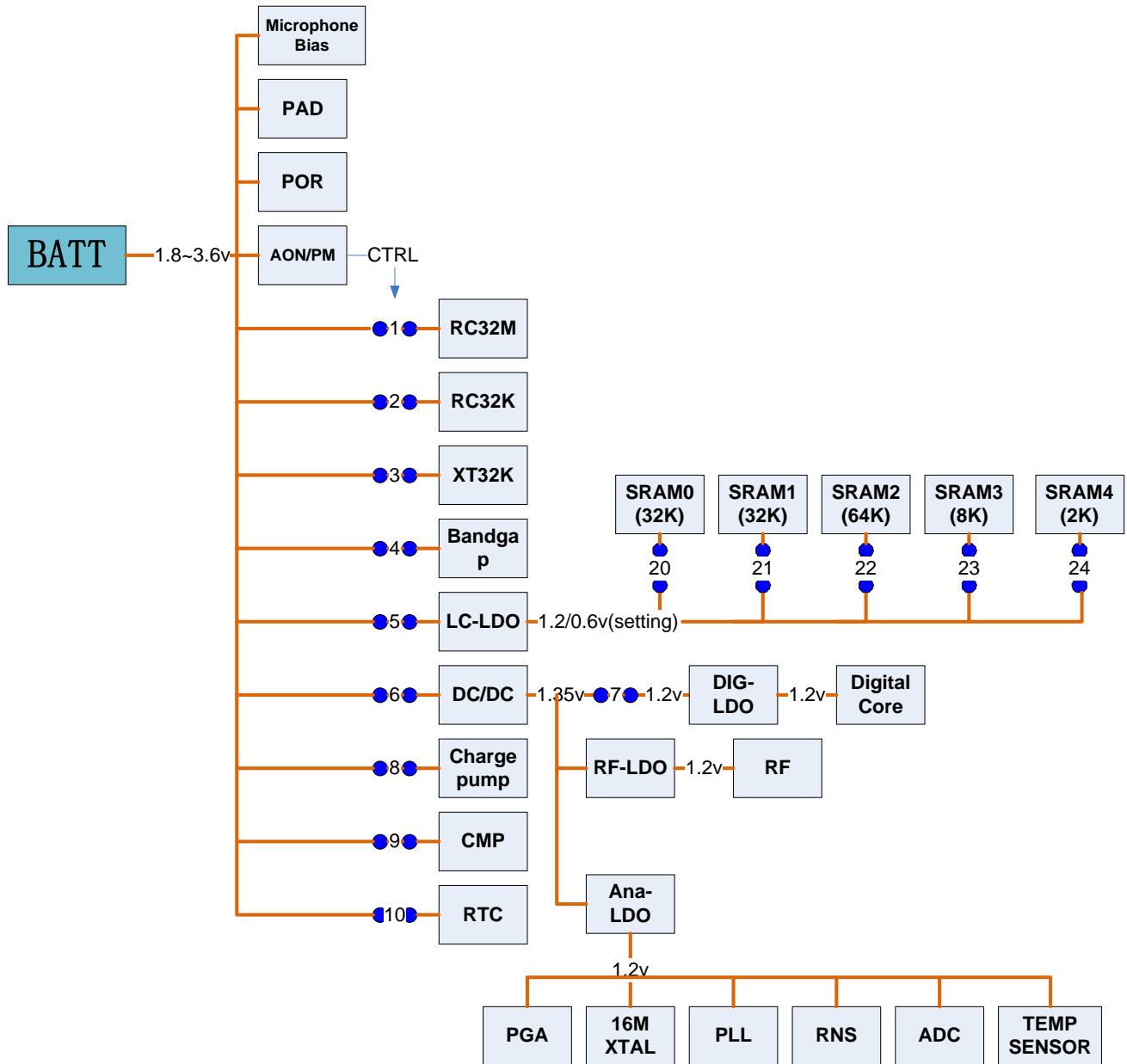

Figure 8: Power system

The following diagram is Normal, Sleep and Off mode. Switches are optional depending on user's request.

Switch	Normal	Sleep	Off
1RC32M	On	Off	Off
2RC32K	On	Optional	Off
3XT32K	On	Optional	Off
4bandgap	On	Off	Off
5LC-LDO	On	on	Off
6DC/DC	On	Off	Off
7DIG-LDO	On	Off	Off
8charge pump	On	Off	Off
9CMP	On	Optional	Off

10RTC	On	Optional	Off
20SRAM-32K	1.2v	0.6v	0
21SRAM-32K	1.2v	0.6v	0
22SRAM-64K	1.2v	0.6v	0
23SRAM-8K	1.2v	0.6v	0
24SRAM-2K	1.2v	0.6v	0

Table 7: Flash Switches of different power modes

3.6 Low Power Features

3.6.1 Operation and Sleep States

3.6.1.1 Normal State

3.6.1.2 Clock Gate State

The CPU executes WFI/WFE to enter clock gate state. After wake-up from clock-gate state, the CPU continues to execute the program from where it stopped. The wake-up sources includes interrupts and events. The wake-up sources are configured by the software according to applications.

3.6.1.3 System Sleep State

The wake-up sources include:

- IO
- RTC
- RESET
- UVLO reset

3.6.1.4 System Off State

The wake-up sources include:

- IOs
- RESET
- UVLO reset

3.6.2 State Transition

3.6.2.1 Entering Clock Gate State and Wake-up

CPU executes WFI/WFE.

3.6.2.2 Entering Sleep/off States and Wake-up

The PM registers identify whether the CPU is in mirror mode or FLASH mode before sleep or off, and record the remap and vectors. The CPU configures the corresponding PM registers to put the chip into sleep or off mode. After wake-up, the chip enters boot mode to execute boot code in the ROM. The ROM code checks the mode before sleep/off and the remap information, perform corresponding configurations, and starts to execute the program.

3.7 Interrupts

Interrupt Name	M0 Interrupt Number
Reserved	0
Reserved	1
cp_timer_irq	2
cp_wdt_irq	3

bb_irq	4
kscan_irq	5
rtc_irq	6
Reserved	7
Reserved	8
timer_irq	9
wdt_irq	10
uart_irq	11
i2c0_irq	12
i2c1_irq	13
spi0_irq	14
spi1_irq	15
gpio_irq	16
i2s_irq	17
spif_irq	18
dmac_intr	19
dmac_inttc	20
dmac_interr	21
fpidc	22
fpdzc	23
fpioc	24
fpufc	25
fpofc	26
fpixc	27
aes_irq	28
adcc_irq	29
qdec_irq	30
rng_irq	31

Table 8: Interrupts

3.8 Clock Management (CLOCK)

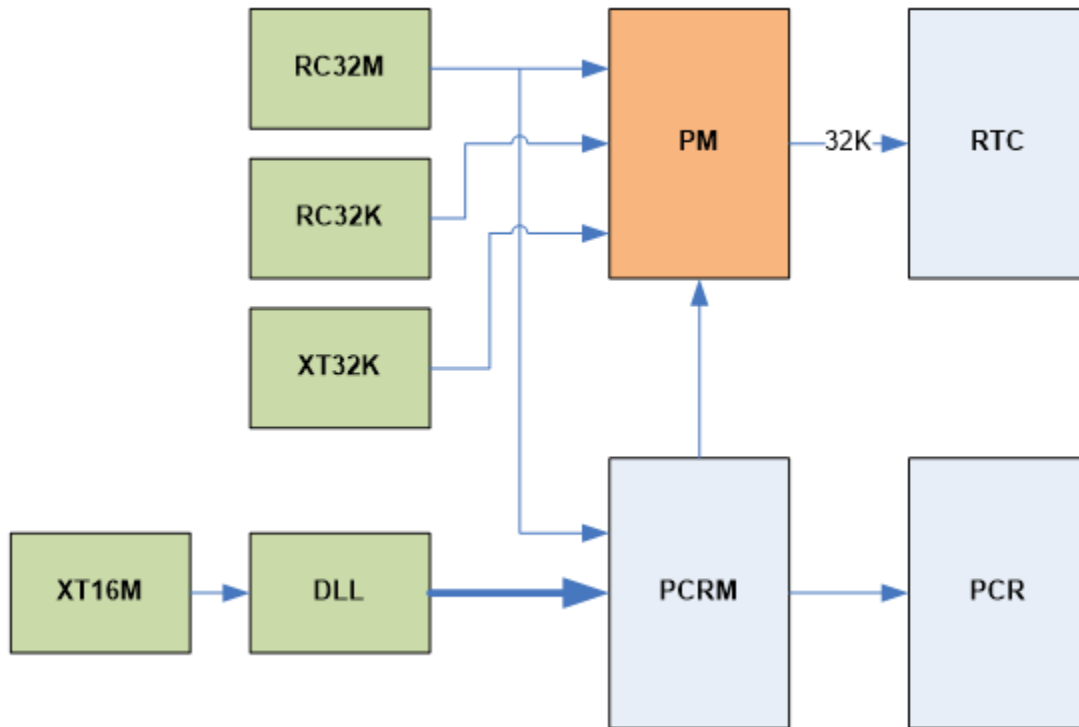

Figure 10: Clock management

There are two crystal clock sources: 16MHz crystal oscillator (XT16M) and 32.768kHz crystal oscillator (XT32k), of which the 32.768k crystal oscillator is optional. There are also two on chip RC oscillators: 32MHz RC oscillator (RC32M) and 32kHz RC oscillator (RC32k), both of which can be calibrated with respect to 16MHz crystal oscillator. If 32.768kHz crystal is not installed, RC32k oscillator would be periodically calibrated and used for RTC. At initial power up or wake up before XT16M oscillator starts up, RC32M is used as the main clock. An on-chip DLL generates higher frequency clocks such as 32/48/64/96MHz from the XT16M clock source.

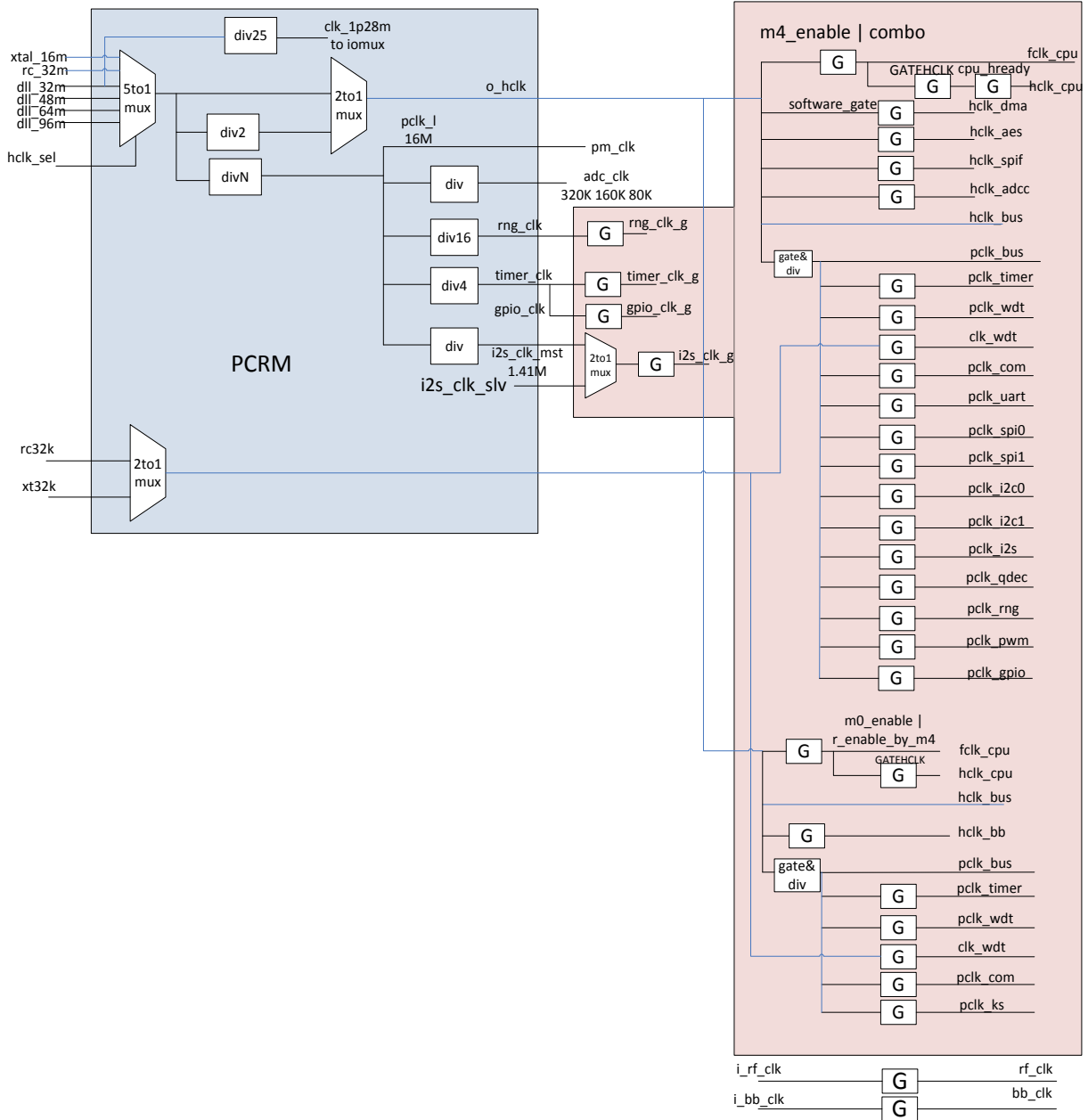

Figure11: Clock structure diagram

3.9 IOMUX

The IOMUX provides a flexible I/O configuration, as the ports of most of the peripherals can be configured and mapped to any of the physical I/O pads (I/O at die boundary). These peripheral modules include I2C 0-1, I2S, UART, PWM 0-5, SPI 0-1, Quadrature Decoder etc. However for other specific purpose peripherals, their I/O mappings are fixed when they are enabled. These specific purpose peripherals include JTAG, analog_ios, GPIOs and key scan.

Figure 12 below shows the IOMUX functional diagram.

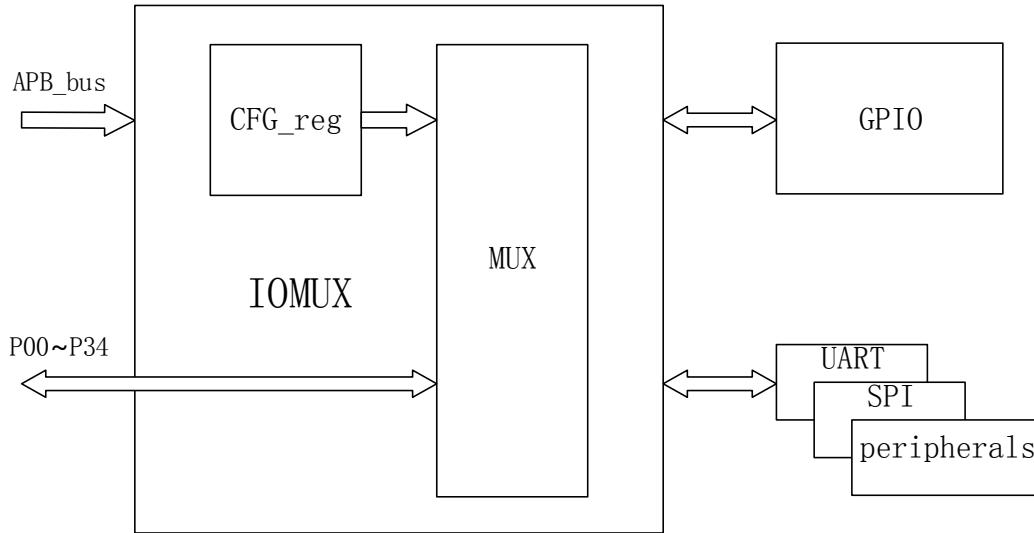

Figure12: IOMUX structure diagram

There are 34 configurable pads which are from P00 to P07 and from P09 to P34. P08 pad is assigned for TM pin which is a test mode pin. The table below shows the mapping of the peripheral IOs that can be mapped through IOMUX. These include I2C 0-1, I2S, UART, PWM 0-5, SPI 0-1, Quadrature Decoder, 1.28MHz clock and dmic_out.

signal name	io	FULLMUX
iic0_scl	B	0
iic0_sda	B	1
iic1_scl	B	2
iic1_sda	B	3
i2s_sck	B	4
i2s_ws	B	5
i2s_sdo0	O	6
i2s_sdo1	O	35
i2s_sdo2	O	36
i2s_sdo3	O	37
i2s_sdi0	I	7
i2s_sdi1	I	38
i2s_sdi2	I	39
i2s_sdi3	I	40
uart_tx	O	8
uart_rx	I	9
pwm0	O	10
pwm1	O	11
pwm2	O	12
pwm3	O	13
pwm4	O	14

pwm5	O	15
spi_0_sck	B	16
spi_0_ssn	B	17
spi_0_tx	O	18
spi_0_rx	I	19
spi_1_sck	B	20
spi_1_ssn	B	21
spi_1_tx	O	22
spi_1_rx	I	23
chax	I	24
chbx	I	25
chix	I	26
chay	I	27
chby	I	28
chiy	I	29
chaz	I	30
chbz	I	31
chiz	I	32
clk_1p28m	O	33
adcc_dmic_out	I	34

On the other hand, there are also special purpose peripherals, whose IOs are fixed to certain physical pads, when these peripheral functions are enabled. These special purpose peripherals include: JTAG, analog I/Os (ADC inputs), GPIO, and key scan. When they are enabled, their IOs are mapped to physical pads according to the following table (by default JTAG is enabled).

QFN32					
0	GPIO_P00	jtag_dout	GPIO		mk_in[0]
1	GPIO_P01	jtag_din	GPIO		mk_out[0]
2	GPIO_P02	jtag_tm	GPIO		mk_in[1]
3	GPIO_P03	jtag_clk	GPIO		mk_out[1]
4	TEST_MODE				
5	GPIO_P09	GPIO			mk_out[4]
6	GPIO_P10	GPIO			mk_in[4]
7	GPIO_P14	GPIO		analog_io[3]	mk_out[2]
8	GPIO_P15	GPIO		analog_io[4]	mk_in[2]
9	GPIO_P16	XTALI(ANA)	GPIO		mk_out[16]
10	GPIO_P17	XTALO(ANA)	GPIO		mk_out[17]
11	GPIO_P18	GPIO		analog_io[7]	mk_in[5]
12	GPIO_P20	GPIO		analog_io[9]	mk_out[5]
13	GPIO_P23	GPIO			mk_in[6]
14	GPIO_P24	GPIO			mk_out[3]
15	GPIO_P25	GPIO			mk_in[3]
16	GPIO_P31	spi_t_ssn	GPIO		mk_out[7]
17	GPIO_P32	spi_t_rx	GPIO		mk_in[7]
18	GPIO_P33	spi_t_tx	GPIO		mk_out[6]
19	GPIO_P34	spi_t_sck	GPIO		mk_in[8]

In the IO Mux table above, the first column is the IO pad mapping in default mode, when no IOMUX function is selected and no special purpose peripherals such as analogIO, GPIO<0:3>, key scan, are enabled. In this mode, pin<0:3> are used for JTAG.

When analog IOs are enabled, pins<11:15>, <18:20> are connected to internal analog IOs. More specifically, analog_io<0:4><9> are connected to ADC inputs, analog_io<7,8> are connected to PGA inputs.

In JTAG mode, data output for JTAG test mode is mapped to P00; data input for JTAG test mode is mapped to P01; mode control input for JTAG test mode is mapped to P02; clock input for JTAG test mode is mapped to P03.

Detailed IOMUX register table and physical IO pad control are shown below.

Base address: 4000_3800

OFFSET	TYPE	RESET	NAME	DESCRIPTION
0x0			r_analog_io	
[31:10]	RW	22'h0	reserved	
[9:0]	RW	10'h60	r_analog_io_en	Analog IO enable
0xc			full_mux0	register description
[31:0]	RW	32'h0	r_func_io_en[31:0]	full mux enable. [8] must set to 0
0x10			full_mux1	register description
[31:3]	RW	29'h0	reserved	
[2:0]	RW	3'h0	r_func_io_en[34:32]	full mux enable
0x14			gpio_papb	register description
[31:17]	RW	15'h0	reserved	
[16]	RW	1'h0	r_gpio_pb_16_en	gpio_16 enable
[15]	RW	1'h0	r_gpio_pb_15_en	gpio_15 enable
[14]	RW	1'h0	r_gpio_pb_14_en	gpio_14 enable
[13]	RW	1'h0	r_gpio_pb_13_en	gpio_13 enable
[12:4]	RW	9'h0	reserved	
[3]	RW	1'h0	r_gpio_pa_03_en	gpio_03 enable
[2]	RW	1'h0	r_gpio_pa_02_en	gpio_02 enable
[1]	RW	1'h0	r_gpio_pa_01_en	gpio_01 enable
[0]	RW	1'h0	r_gpio_pa_00_en	gpio_00 enable
0x18			func_io0	register description
[31:30]	RW	2'h0	reserved	
[29:24]	RW	6'h0	r_func_io03_sel	pad 3 full mux function select
[23:22]	RW	2'h0	reserved	

[21:16]	RW	6'h0	r_func_io02_sel	pad 2 full mux function select
[15:14]	RW	2'h0	reserved	
[13:8]	RW	6'h0	r_func_io01_sel	pad 1 full mux function select
[7:6]	RW	2'h0	reserved	
[5:0]	RW	6'h0	r_func_io00_sel	pad 0 full mux function select

0x1c	func_io1			register description
[31:30]	RW	2'h0	reserved	
[29:24]	RW	6'h0	r_func_io07_sel	pad 7 full mux function select
[23:22]	RW	2'h0	reserved	
[21:16]	RW	6'h0	r_func_io06_sel	pad 6 full mux function select
[15:14]	RW	2'h0	reserved	
[13:8]	RW	6'h0	r_func_io05_sel	pad 5 full mux function select
[7:6]	RW	2'h0	reserved	
[5:0]	RW	6'h0	r_func_io04_sel	pad 4 full mux function select

0x20	func_io2			register description
[31:30]	RW	2'h0	reserved	
[29:24]	RW	6'h0	r_func_io11_sel	pad 11 full mux function select
[23:22]	RW	2'h0	reserved	
[21:16]	RW	6'h0	r_func_io10_sel	pad 10 full mux function select
[15:14]	RW	2'h0	reserved	
[13:8]	RW	6'h0	r_func_io09_sel	pad 9 full mux function select
[7:6]	RW	2'h0	reserved	
[5:0]	RW	6'h0	r_func_io08_sel	pad 8 full mux function select. not used. can delete

0x24	func_io3			register description
[31:30]	RW	2'h0	reserved	
[29:24]	RW	6'h0	r_func_io15_sel	pad 15 full mux function select
[23:22]	RW	2'h0	reserved	
[21:16]	RW	6'h0	r_func_io14_sel	pad 14 full mux function select
[15:14]	RW	2'h0	reserved	
[13:8]	RW	6'h0	r_func_io13_sel	pad 13 full mux function select
[7:6]	RW	2'h0	reserved	
[5:0]	RW	6'h0	r_func_io12_sel	pad 12 full mux function select

0x28	func_io4			register description
[31:30]	RW	2'h0	reserved	
[29:24]	RW	6'h0	r_func_io19_sel	pad 19 full mux function select
[23:22]	RW	2'h0	reserved	
[21:16]	RW	6'h0	r_func_io18_sel	pad 18 full mux function select

[15:14]	RW	2'h0	reserved	
[13:8]	RW	6'h0	r_func_io17_sel	pad 17 full mux function select
[7:6]	RW	2'h0	reserved	
[5:0]	RW	6'h0	r_func_io16_sel	pad 16 full mux function select

0x2c			func_io5	register description
[31:30]	RW	2'h0	reserved	
[29:24]	RW	6'h0	r_func_io23_sel	pad 23 full mux function select
[23:22]	RW	2'h0	reserved	
[21:16]	RW	6'h0	r_func_io22_sel	pad 22 full mux function select
[15:14]	RW	2'h0	reserved	
[13:8]	RW	6'h0	r_func_io21_sel	pad 21 full mux function select
[7:6]	RW	2'h0	reserved	
[5:0]	RW	6'h0	r_func_io20_sel	pad 20 full mux function select

0x30			func_io6	register description
[31:30]	RW	2'h0	reserved	
[29:24]	RW	6'h0	r_func_io27sel	pad 27 full mux function select
[23:22]	RW	2'h0	reserved	
[21:16]	RW	6'h0	r_func_io26_sel	pad 26 full mux function select
[15:14]	RW	2'h0	reserved	
[13:8]	RW	6'h0	r_func_io25_sel	pad 25 full mux function select
[7:6]	RW	2'h0	reserved	
[5:0]	RW	6'h0	r_func_io24_sel	pad 24 full mux function select

0x34			func_io7	register description
[31:30]	RW	2'h0	reserved	
[29:24]	RW	6'h0	r_func_io31sel	pad 31 full mux function select
[23:22]	RW	2'h0	reserved	
[21:16]	RW	6'h0	r_func_io30_sel	pad 30 full mux function select
[15:14]	RW	2'h0	reserved	
[13:8]	RW	6'h0	r_func_io29_sel	pad 29 full mux function select
[7:6]	RW	2'h0	reserved	
[5:0]	RW	6'h0	r_func_io28_sel	pad 28 full mux function select

0x38			func_io8	register description
[31:22]	RW	10'h0	reserved	
[21:16]	RW	6'h0	r_func_io34_sel	pad 34 full mux function select
[15:14]	RW	2'h0	reserved	
[13:8]	RW	6'h0	r_func_io33_sel	pad 33 full mux function select
[7:6]	RW	2'h0	reserved	
[5:0]	RW	6'h0	r_func_io32_sel	pad 32 full mux function select

0x4C		key_scan_in_en		register description
[31:16]	RW	16'h0	reserved	
[15:0]	RW	16'h0	r_kscan_in_en	key scan in enable

0x50		key_scan_out_en		register description
[31:18]	RW	14'h0	reserved	
[17:0]	RW	18'h0	r_kscan_out_en	key scan out enable

Physical IO PAD control registers:

Base address: 4000_F000.

0xF008		IOCTL0	
[31 : 30]	RW	2'd0	
[29 : 28]	RW	2'b0	pull up/down control of pin 09 00: floating, no pull up and pull down 01: weak pull up 10: strong pull up 11: pull down
[27]	RW	1'b0	wake up polarity select of pin 09 0: active POSEDGE 1: active NEGEDGE
[26 : 24]	RW	3'b110	P08 is used for test mode config pin
[23 : 22]	RW	2'b0	pull up/down control of pin 07 00: floating, no pull up and pull down 01: weak pull up 10: strong pull up 11: pull down
[21]	RW	1'b0	wake up polarity select of pin 07 0: active POSEDGE 1: active NEGEDGE
[20 : 19]	RW	2'b0	pull up/down control of pin 06 00: floating, no pull up and pull down 01: weak pull up 10: strong pull up 11: pull down
[18]	RW	1'b0	wake up polarity select of pin 06 0: active POSEDGE 1: active NEGEDGE
[17 : 16]	RW	2'b0	pull up/down control of pin 05 00: floating, no pull up and pull down 01: weak pull up 10: strong pull up 11: pull down

[15]	RW	1'b0	wake up polarity select of pin 05 0: active POSEDGE 1: active NEGEDGE
[14 : 13]	RW	2'b0	pull up/down control of pin 04 00: floating, no pull up and pull down 01: weak pull up 10: strong pull up 11: pull down
[12]	RW	1'b0	wake up polarity select of pin 04 0: active POSEDGE 1: active NEGEDGE
[11 : 10]	RW	2'b11	pull up/down control of pin 03 00: floating, no pull up and pull down 01: weak pull up 10: strong pull up 11: pull down
[9]	RW	1'b0	wake up polarity select of pin 03 0: active POSEDGE 1: active NEGEDGE
[8 : 7]	RW	2'b0	pull up/down control of pin 02 00: floating, no pull up and pull down 01: weak pull up 10: strong pull up 11: pull down
[6]	RW	1'b0	wake up polarity select of pin 02 0: active POSEDGE 1: active NEGEDGE
[5 : 4]	RW	2'b0	pull up/down control of pin 01 00: floating, no pull up and pull down 01: weak pull up 10: strong pull up 11: pull down
[3]	RW	1'b0	wake up polarity select of pin 01 0: active POSEDGE 1: active NEGEDGE
[2 : 1]	RW	2'b0	pull up/down control of pin 00 00: floating, no pull up and pull down 01: weak pull up 10: strong pull up 11: pull down
[0]	RW	1'b0	wake up polarity select of pin 00 0: active POSEDGE 1: active NEGEDGE

0xF00C			IOCTL1
[31 : 30]	RW	2'd0	

[29 : 28]	RW	2'b0	pull up/down control of pin 19 00: floating, no pull up and pull down 01: weak pull up 10: strong pull up 11: pull down
[27]	RW	1'b0	wake up polarity select of pin 19 0: active POSEDGE 1: active NEGEDGE
[26 : 25]	RW	2'b0	pull up/down control of pin 18 00: floating, no pull up and pull down 01: weak pull up 10: strong pull up 11: pull down
[24]	RW	1'b0	wake up polarity select of pin 18 0: active POSEDGE 1: active NEGEDGE
[23 : 22]	RW	2'b0	pull up/down control of pin 17 00: floating, no pull up and pull down 01: weak pull up 10: strong pull up 11: pull down
[21]	RW	1'b0	wake up polarity select of pin 17 0: active POSEDGE 1: active NEGEDGE
[20 : 19]	RW	2'b0	pull up/down control of pin 16 00: floating, no pull up and pull down 01: weak pull up 10: strong pull up 11: pull down
[18]	RW	1'b0	wake up polarity select of pin 16 0: active POSEDGE 1: active NEGEDGE
[17 : 16]	RW	2'b0	pull up/down control of pin 15 00: floating, no pull up and pull down 01: weak pull up 10: strong pull up 11: pull down
[15]	RW	1'b0	wake up polarity select of pin 15 0: active POSEDGE 1: active NEGEDGE
[14 : 13]	RW	2'b0	pull up/down control of pin 14 00: floating, no pull up and pull down 01: weak pull up 10: strong pull up 11: pull down

[12]	RW	1'b0	wake up polarity select of pin 14 0: active POSEDGE 1: active NEGEDGE
[11 : 10]	RW	2'b0	pull up/down control of pin 13 00: floating, no pull up and pull down 01: weak pull up 10: strong pull up 11: pull down
[9]	RW	1'b0	wake up polarity select of pin 13 0: active POSEDGE 1: active NEGEDGE
[8 : 7]	RW	2'b0	pull up/down control of pin 12 00: floating, no pull up and pull down 01: weak pull up 10: strong pull up 11: pull down
[6]	RW	1'b0	wake up polarity select of pin 12 0: active POSEDGE 1: active NEGEDGE
[5 : 4]	RW	2'b0	pull up/down control of pin 11 00: floating, no pull up and pull down 01: weak pull up 10: strong pull up 11: pull down
[3]	RW	1'b0	wake up polarity select of pin 11 0: active POSEDGE 1: active NEGEDGE
[2 : 1]	RW	2'b0	pull up/down control of pin 10 00: floating, no pull up and pull down 01: weak pull up 10: strong pull up 11: pull down
[0]	RW	1'b0	wake up polarity select of pin 10 0: active POSEDGE 1: active NEGEDGE

0xF010 IOCTL2

[31 : 30]	RW	2'd0	
[29 : 28]	RW	2'b0	pull up/down control of pin 29 00: floating, no pull up and pull down 01: weak pull up 10: strong pull up 11: pull down
[27]	RW	1'b0	wake up polarity select of pin 29 0: active POSEDGE 1: active NEGEDGE

[26 : 25]	RW	2'b0	pull up/down control of pin 28 00: floating, no pull up and pull down 01: weak pull up 10: strong pull up 11: pull down
[24]	RW	1'b0	wake up polarity select of pin 28 0: active POSEDGE 1: active NEGEDGE
[23 : 22]	RW	2'b0	pull up/down control of pin 27 00: floating, no pull up and pull down 01: weak pull up 10: strong pull up 11: pull down
[21]	RW	1'b0	wake up polarity select of pin 27 0: active POSEDGE 1: active NEGEDGE
[20 : 19]	RW	2'b0	pull up/down control of pin 26 00: floating, no pull up and pull down 01: weak pull up 10: strong pull up 11: pull down
[18]	RW	1'b0	wake up polarity select of pin 26 0: active POSEDGE 1: active NEGEDGE
[17 : 16]	RW	2'b11	pull up/down control of pin 25 00: floating, no pull up and pull down 01: weak pull up 10: strong pull up 11: pull down
[15]	RW	1'b0	wake up polarity select of pin 25 0: active POSEDGE 1: active NEGEDGE
[14 : 13]	RW	2'b11	pull up/down control of pin 24 00: floating, no pull up and pull down 01: weak pull up 10: strong pull up 11: pull down
[12]	RW	1'b0	wake up polarity select of pin 24 0: active POSEDGE 1: active NEGEDGE
[11 : 10]	RW	2'b0	pull up/down control of pin 23 00: floating, no pull up and pull down 01: weak pull up 10: strong pull up 11: pull down
[9]	RW	1'b0	wake up polarity select of pin 23 0: active POSEDGE 1: active NEGEDGE

[8 : 7]	RW	2'b0	pull up/down control of pin 22 00: floating, no pull up and pull down 01: weak pull up 10: strong pull up 11: pull down
[6]	RW	1'b0	wake up polarity select of pin 22 0: active POSEDGE 1: active NEGEDGE
[5 : 4]	RW	2'b0	pull up/down control of pin 21 00: floating, no pull up and pull down 01: weak pull up 10: strong pull up 11: pull down
[3]	RW	1'b0	wake up polarity select of pin 21 0: active POSEDGE 1: active NEGEDGE
[2 : 1]	RW	2'b0	pull up/down control of pin 20 00: floating, no pull up and pull down 01: weak pull up 10: strong pull up 11: pull down
[0]	RW	1'b0	wake up polarity select of pin 20 0: active POSEDGE 1: active NEGEDGE

3.10 GPIO

The General Purpose I/Os are a type of peripheral that can be mapped to physical I/O pads and programmed by software. The flexible GPIO are organized as two PORTs. Among them, PortA has bi-direction 18 bit lines, e.g., GPIO_PORTA[17:0], while PortB has 17 bi-directional bit lines, e.g., PIO_PORTB[16:0]. With default setting, physical pads: P00-P17 are connected to to PortA; Pads P18-34 are connected to PortB, when all GPIOs are enabled, as described in the IOMUX table in IOMUX section.

All PortA and PortB pins can be configured as bi-directional serial interface, by selecting as input or output direction, and their corresponding data can be either read from or written to registers. All PortA and PortB pins support wake-up, but only 18 PortA pins support interrupt. Also only PortA pins support debounce function.

Each GPIO pins can be pulled up to AVDD33 or pulled down to ground by adding pull up or pull down resistors to have default functions/states.

For more detailed info, please refer to “CMT4501 GPIO Application Notes”, in software SDK document folder. Blow table are the Registers related to GPIOs.

Base address: 0x4000_8000

OFFSET	TYPE	RESET	NAME	DESCRIPTION
0x00			gpio_swporta_dr	
[31:18]	RO	14'b0	Reserved	Reserved
[17:0]	RW	18'b0	Port A Data Register	Values written to this register are output on the I/O signals for Port A
0x04			gpio_swporta_dds	
[31:18]	RO	14'b0	Reserved	Reserved
[17:0]	RW	18'b0	Port A Data Direction Register	Values written to this register independently control the direction of the corresponding data bit in Port A 1'b0: Input 1'b1: Output
0x08			gpio_swporta_ctl	
[31:1]	RO	31'b0	Reserved	Reserved
[0]	RW	1'b0	Port A Data Source	The data and control source for a signal can come from either software or hardware 1'b0: Software mode 1'b1: Hardware mode
0x0c			gpio_swportb_dr	
[31:15]	RO	15'b0	Reserved	Reserved
[16:0]	RW	17'b0	Port B Data Register	Values written to this register are output on the I/O signals for Port B
0x10			gpio_swportb_dds	
[31:15]	RO	15'b0	Reserved	Reserved
[16:0]	RW	17'b0	Port B Data Direction Register	Values written to this register independently control the direction of the corresponding data bit in Port B 1'b0: Input 1'b1: Output
0x14			gpio_swportb_ctl	
[31:1]	RO	31'b0	Reserved	Reserved
[0]	RW	1'b0	Port B Data Source	The data and control source for a signal can come from either software or hardware 1'b0: Software mode 1'b1: Hardware mode
0x30			gpio_inten	
[31:18]	RO	14'b0	Reserved	Reserved
[17:0]	RW	18'b0	Interrupt enable	Allows each bit of Port A to be configured for interrupts 1'b0: Configure Port A bit as normal GPIO signal 1'b1: Configure Port A bit as interrupt
0x34			gpio_intmask	
[31:18]	RO	14'b0	Reserved	Reserved
[17:0]	RW	18'b0	Interrupt mask	Controls whether an interrupt on Port A can create an interrupt for the interrupt controller by not masking it 1'b0: Interrupt bits are unmasked 1'b1: Mask interrupt
0x38			gpio_inttype_level	

[31:18]	RO	14'b0	Reserved	Reserved
[17:0]	RW	18'b0	Interrupt level	Controls the type of interrupt that can occur on Port A 1'b0: Level-sensitive 1'b1: Edge-sensitive
0x3c			gpio_int_polarity	
[31:18]	RO	14'b0	Reserved	Reserved
[17:0]	RW	18'b0	Interrupt polarity	Controls the polarity of edge or level sensitivity that can occur on input of Port A 1'b0: Active-low or falling-edge 1'b1: Active-high or rising-edge
0x40			gpio_intstatus	
[31:18]	RO	14'b0	Reserved	Reserved
[17:0]	RO	18'b0	Interrupt status	Interrupt status of Port A
0x44			gpio_raw_intstatus	
[31:18]	RO	14'b0	Reserved	Reserved
[17:0]	RO	18'b0	Raw interrupt status	Raw interrupt of status of Port A
0x48			gpio_debounce	
[31:18]	RO	14'b0	Reserved	Reserved
[17:0]	RW	18'b0	Debounce enable	Controls whether an external signal that is the source of an interrupt needs to be debounced to remove any spurious glitches 1'b0: No debounce 1'b1: Enable debounce
0x4c			gpio_porta_eoi	
[31:18]	RO	14'b0	Reserved	Reserved
[17:0]	WO	18'b0	Clear interrupt	Controls the clearing of edge type interrupts from Port A 1'b0: No interrupt clear 1'b1: Clear interrupt
0x50			gpio_ext_porta	
[31:18]	RO	14'b0	Reserved	Reserved
[17:0]	RO	18'b0	External Port A	When Port A is configured as Input, then reading this location reads the values on the signal. When the data direction of Port A is set as Output, reading this location reads the data register for Port A
0x54			gpio_ext_portb	
[31:17]	RO	15'b0	Reserved	Reserved
[16:0]	RO	17'b0	External Port B	When Port B is configured as Input, then reading this location reads the values on the signal. When the data direction of Port B is set as Output, reading this location reads the data register for Port B
0x60			gpio_ls_sync	
[31:1]	RO	31'b0	Reserved	Reserved
[0]	RW	1'b0	Synchronization level	Writing a 1 to this register results in all level-sensitive interrupts being synchronized to pclk_intr 1'b0: No synchronization to pclk_intr 1'b1: Synchronize to pclk_intr

0x64		gpio_id_code		
[31:16]	RO	16'b0	Reserved	Reserved
[15:0]	RO	16'b0	GPIO ID code	This is a user-specified code that a system can read. It can be used for chip identification, and so on
0x6c		gpio_ver_id_code		
[31:0]	RO	32'b0	GPIO Component Version	ASCII value for each number in the version
0x74		gpio_config_reg1		
[31:21]	RO	11'b0	Reserved	Reserved
[20:16]	RO	5'b0x0f	ENCODED_ID_WIDTH	The value of this register is equal to GPIO_ID_WIDTH-1
[15]	RO	1'b0	GPIO_ID	The value of this register is derived from the GPIO_ID configuration parameter 1'b0: Exclude 1'b1: Include
[14]	RO	1'b0	ADD_ENCODED_PARAMS	The value of this register is derived from the GPIO_ADD_ENCODED_PARAMS configuration parameter 1'b0: False 1'b1: True
[13]	RO	1'b0	DEBOUNCE	The value of this register is derived from the GPIO_DEBOUNCE configuration parameter 1'b0: Exclude 1'b1: Include
[12]	RO	1'b0	PORTA_INTR	The value of this register is derived from the GPIO_PORTA_INTR configuration parameter 1'b0: Exclude 1'b1: Include
[11]	RO	1'b0	Reserved	Reserved
[10]	RO	1'b0	Reserved	Reserved
[9]	RO	1'b0	HW_PORTB	The value of this register is derived from the GPIO_HW_PORTB configuration parameter 1'b0: Exclude 1'b1: Include
[8]	RO	1'b0	HW_PORTA	The value of this register is derived from the GPIO_HW_PORTA configuration parameter 1'b0: Exclude 1'b1: Include
[7]	RO	1'b0	Reserved	Reserved
[6]	RO	1'b0	Reserved	Reserved
[5]	RO	1'b0	PORTB_SINGLE_CTL	The value of this register is derived from the GPIO_PORTB_SINGLE_CTL configuration parameter 1'b0: False 1'b1: True
[4]	RO	1'b0	PORTA_SINGLE_CTL	The value of this register is derived from the GPIO_PORTA_SINGLE_CTL configuration parameter 1'b0: False 1'b1: True

[3:2]	RO	2'b0x2	NUM_PORTS	The value of this register is derived from the GPIO_NUM_PORT configuration parameter 2'b00 1 2'b01 2 2'b10 3 2'b11 4
[1:0]	RO	2'b0x2	APB_DATA_WIDTH	The value of this register is derived from the GPIO_APB_DATA_WIDTH configuration parameter 2'b00 8 bits 2'b01 16 bits 2'b10 32 bits 2'b11 Reserved
0x70			gpio_config_reg2	
[31:10]	RO	22'b0	Reserved	Reserved
[9:5]	RO	5'b0x0f	ENCODED_ID_PWIDTH_B	The value of this register is equal to GPIO_PWIDTH_B-1
[4:0]	RO	5'b0x11	ENCODED_ID_PWIDTH_A	The value of this register is equal to GPIO_PWIDTH_A-1

4 Peripheral Blocks

4.1 2.4GHz Radio

The 2.4 GHz RF transceiver is designed to operate in the worldwide ISM frequency band at 2.4 to 2.4835 GHz. Radio modulation modes and configurable packet structure make the transceiver interoperable with *Bluetooth*® low energy (BLE) protocol implementations.

- General modulation format
 - FSK (configurable modulation index) with configurable Gaussian Filter Shaping
 - OQPSK with half-sine shaping
 - On-air data rates
 - 125kbps/250kbps/500kbps/1Mbps/2Mbps
- Transmitter with programmable output power of -20dBm to +10dBm, in 3dB steps
- RSSI function (1 dB resolution, ± 2 dB accuracy)
- Receiver sensitivity
 - -103dBm@125Kbps GFSK
 - -98dBm@500Kbps GFSK
 - -97dBm@1Mbps BLE
 - -94dBm@2Mbps BLE
- Embedded RF balun
- Integrated frac-N synthesizer with phase modulation

4.2 Timer/Counters (TIMER)

The implementation can include a 24-bit SysTick system timer, that extends the functionality of both the processor and the NVIC. When present, the NVIC part of the extension provides:

- A 24-bit system timer (SysTick)

- Additional configurable priority SysTick interrupt.
- See the ARMv7-M ARM for more information.

General purpose timers are included in the design. This timer is Synopsys DW_apb_timer. With the input clock running at 4Mhz.

The timer related registers are listed below, and there are two sets of identical timers.

Base address: Timer setA: 4000_1000, timer_setB: 4002_1000

OFFSET	TYPE	RESET	NAME	DESCRIPTION
0x00			Timer1LoadCount	
[31:24]	RO	8'b0	Reserved	Reserved
[23:0]	RW	24'b0	Timer1 Load Count Register	Value to be loaded into Timer1
0x04			Timer1CurrentValue	
[31:24]	RO	8'b0	Reserved	Reserved
[23:0]	RO	24'b0	Timer1 Current Value Register	Current Value of Timer1
0x08			Timer1ControlReg	
[31:3]	RO	29'b0	Reserved	Reserved
[2]	RW	1'b0	Timer Interrupt Mask	Timer interrupt mask for Timer1 1'b0: not masked 1'b1: masked
[1]	RW	1'b0	Timer Mode	Timer mode for Timer1 1'b0: free-running mode 1'b1: user-defined count mode
[0]	RW	1'b0	Timer Enable	Timer enable bit for Timer1 1'b0: disable 1'b1: enable
0x0c			Timer1EOI	
[31:1]	RO	31'b0	Reserved	Reserved
[0]	RO	1'b0	Timer1 End of-Interrupt Register	Reading from this register returns all zeroes (0) and clears the interrupt from Timer1
0x10			Timer1IntStatus	
[31:1]	RO	31'b0	Reserved	Reserved
[0]	RO	1'b0	Timer1 Interrupt Status Register	Contains the interrupt status for Timer1
0x14			Timer2LoadCount	
[31:24]	RO	8'b0	Reserved	Reserved
[23:0]	RW	24'b0	Timer2 Load Count Register	Value to be loaded into Timer2
0x18			Timer2CurrentValue	
[31:24]	RO	8'b0	Reserved	Reserved
[23:0]	RO	24'b0	Timer2 Current Value Register	Current Value of TimerN
0x1c			Timer2ControlReg	
[31:3]	RO	29'b0	Reserved	Reserved
[2]	RW	1'b0	Timer Interrupt Mask	Timer interrupt mask for Timer2 1'b0: not masked 1'b1: masked

[1]	RW	1'b0	Timer Mode	Timer mode for Timer2 1'b0: free-running mode 1'b1: user-defined count mode
[0]	RW	1'b0	Timer Enable	Timer enable bit for Timer2 1'b0: disable 1'b1: enable
0x20 Timer2EOI				
[31:1]	RO	31'b0	Reserved	Reserved
[0]	RO	1'b0	Timer2 End-of-Interrupt Register	Reading from this register returns all zeroes (0) and clears the interrupt from Timer2
0x24 Timer2IntStatus				
[31:1]	RO	31'b0	Reserved	Reserved
[0]	RO	1'b0	Timer2 Interrupt Status Register	Contains the interrupt status for Timer2
0x28 Timer3LoadCount				
[31:24]	RO	8'b0	Reserved	Reserved
[23:0]	RW	24'b0	Timer3 Load Count Register	Value to be loaded into Timer3
0x2c Timer3CurrentValue				
[31:24]	RO	8'b0	Reserved	Reserved
[23:0]	RO	24'b0	Timer3 Current Value Register	Current Value of TimerN
0x30 Timer3ControlReg				
[31:3]	RO	29'b0	Reserved	Reserved
[2]	RW	1'b0	Timer Interrupt Mask	Timer interrupt mask for Timer3 1'b0: not masked 1'b1: masked
[1]	RW	1'b0	Timer Mode	Timer mode for Timer3 1'b0: free-running mode 1'b1: user-defined count mode
[0]	RW	1'b0	Timer Enable	Timer enable bit for Timer3 1'b0: disable 1'b1: enable
0x34 Timer3EOI				
[31:1]	RO	31'b0	Reserved	Reserved
[0]	RO	1'b0	Timer3 End-of-Interrupt Register	Reading from this register returns all zeroes (0) and clears the interrupt from Timer3
0x38 Timer3IntStatus				
[31:1]	RO	31'b0	Reserved	Reserved
[0]	RO	1'b0	Timer3 Interrupt Status Register	Contains the interrupt status for Timer3
0x3c Timer4LoadCount				
[31:24]	RO	8'b0	Reserved	Reserved
[23:0]	RW	24'b0	Timer4 Load Count Register	Value to be loaded into Timer4
0x40 Timer4CurrentValue				
[31:24]	RO	8'b0	Reserved	Reserved
[23:0]	RO	24'b0	Timer4 Current Value Register	Current Value of Timer4
0x44 Timer4ControlReg				

[31:3]	RO	29'b0	Reserved	Reserved
[2]	RW	1'b0	Timer Interrupt Mask	Timer interrupt mask for Timer4 1'b0: not masked 1'b1: masked
[1]	RW	1'b0	Timer Mode	Timer mode for Timer4 1'b0: free-running mode 1'b1: user-defined count mode
[0]	RW	1'b0	Timer Enable	Timer enable bit for Timer4 1'b0: disable 1'b1: enable
0x48			Timer4EOI	
[31:1]	RO	31'b0	Reserved	Reserved
[0]	RO	1'b0	Timer4 End of-Interrupt Register	Reading from this register returns all zeroes (0) and clears the interrupt from Timer4
0x4c			Timer4IntStatus	
[31:1]	RO	31'b0	Reserved	Reserved
[0]	RO	1'b0	Timer4 Interrupt Status Register	Contains the interrupt status for Timer4
0xa0			TimersIntStatus	
[31:4]	RO	28'b0	Reserved	Reserved
[3:0]	RO	4'b0	Timers Interrupt Status Register	Contains the interrupt status of all timers in the component 0: either timer_intr or timer_intr_n is not active after masking 1: either timer_intr or timer_intr_n is active after masking
0xa4			TimersEOI	
[31:4]	RO	28'b0	Reserved	Reserved
[3:0]	RO	4'b0	Timers End of-Interrupt Register	Reading this register returns all zeroes (0) and clears all active interrupts
0xa8			TimersRawIntStatus	
[31:4]	RO	28'b0	Reserved	Reserved
[3:0]	RO	4'b0	Timers Raw Interrupt Status Register	The register contains the unmasked interrupt status of all timers in the component 0: either timer_intr or timer_intr_n is not active prior to masking 1: either timer_intr or timer_intr_n is active prior to masking
0xac			TimersRawIntStatus	
[31:0]	RO	32'b0	Timers Component Version	Current revision number of the DW_apb_timers component

4.3 Real Time Counter (RTC)

The Real Time Counter (RTC) module provides a generic, low power timer on the low-frequency clock source (LFCLK). The RTC features a 24 bit COUNTER, 12 bit (1/X) prescaler, capture/compare registers, and a tick event generator for low power, tickless RTOS implementation.

RTC related registers are listed below:

Base address: 4000_F000

0xF024 **RTCCTL**

[31 : 24]	RW	8'h0	
	RW	1'b0	Counter overflow event enable.
[23]			1'b0: disable 1'b1: enable
	RW	1'b0	Comparator 2 event enable.
[22]			1'b0: disable 1'b1: enable
	RW	1'b0	Comparator 1 event enable.
[21]			1'b0: disable 1'b1: enable
	RW	1'b0	Comparator 0 event enable.
[20]			1'b0: disable 1'b1: enable
	RW	1'b0	RTC tick event enable.
[19]			1'b0: disable 1'b1: enable
	RW	1'b0	Counter overflow interrupt enable.
[18]			1'b0: disable 1'b1: enable
	RW	1'b0	Comparator 2 interrupt enable.
[17]			1'b0: disable 1'b1: enable
	RW	1'b0	Comparator 1 interrupt enable.
[16]			1'b0: disable 1'b1: enable
	RW	1'b0	Comparator 0 interrupt enable.
[15]			1'b0: disable 1'b1: enable
	RW	1'b0	RTC tick interrupt enable.
[14]			1'b0: disable 1'b1: enable
[13 : 2]	RW	12'h0	12bit prescaler for RTC counter frequency (32768/(PRESCALER+1)).Can be written only when RTC is stopped.
	RW	1'b0	RTC counter clear bit. Write 1'b1 will clear RTC counter and after one clock this bit will return to 1'b0.
[1]			
	RW	1'b0	RTC run/stop control.
[0]			1'b0: stop 1'b1: run

0xF028		RTCCNT	
[31 : 24]	RO	8'h0	
	RO	24'h0	Writing32'h5A5AA5A5 can trigger the overflow task that sets the RTC counter value to 24'hFFFFFF0 to allow SW test of the overflow condition.
[23 : 0]			Reading can read the value of RTC counter (low 24 bits).

0xF02C		RTCCC0		
[31 : 24]	RW	8'h0		
[23 : 0]	RW	24'h0		Compare value of comparator 0
0xF030		RTCCC1		
[31 : 24]	RW	8'h0		
[23 : 0]	RW	24'h0		Compare value of comparator 1
0xF034		RTCCC2		
[31 : 24]	RW	8'h0		
[23 : 0]	RW	24'h0		Compare value of comparator 2
0xF038		RTCFLAG		
[31 : 4]	R	28'h0		
[3]	RO	1'b0		Overflow result flag.
[2]	RO	1'b0		Compare result flag of comparator 2.
[1]	RO	1'b0		Compare result flag of comparator 1.
[0]	RO	1'b0		Compare result flag of comparator 0.

4.4 AES-ECB Encryption (ECB)

The ECB encryption block supports 128 bit AES encryption. It can be used for a range of cryptographic functions like hash generation, digital signatures, and keystream generation for data encryption/decryption.

AES-ECB related registers are listed below:

Base address:4004_0000

OFFSET	TYPE	RESET	NAME	DESCRIPTION
0x00		AES layer enable register		
[31:1]	—	31'b0	reserved	
[0]	RW	1'b0	Enable	Setting this bit to “1” will enable AES to do TX/RX
0x04		AES layer control register		
[31:17]	—	15'b0	reserved	
[16]	RW	1'b0	Fifo out/in (PDU)	if pdu is little-endian set 0;if pdu is big-endian set 1
[15:12]	—	4'b0	reserved	

				[11]:data out: if it is little-endian set 0 if it is big-endian set 1
[11:8]	RW	4'b0	Enginne revert	[10]:xor data :1 [9]: key : if it is little-endian set 0 if it is big-endian set 1
				[8]:data if it is little-endian set 0 if it is big-endian set 1
[7:5]	—	3'b0	reserved	
[4]	RW	1'b0	Aes_single mode	Aes single mode
[3]	RW	1'b0	Code_mode	Encrypt /decrypt
[2:0]	—	3'b0	reserved	
0x08 AES reserved register				
[31:0]	—	32'b0	reserved	
0x0c AES plen & aad register				
[31:16]	—	16'b0	reserved	
[15:8]	RW	8'b0	plen	Packet length
[7:0]	RW	8'b0	aad	aad
0x10 AES interrupt mask register				
[31:4]	—	28'b0	reserved	
[3:0]	RW	4'b0	Aes interrupt enable	[0]: encrypt done;[1]: decrypt failed;[2]: decrypt ok;[3] single mode done
0x14 AES interrupt status register				
[31:4]	—	28'b0	reserved	
[3:0]	RO	4'b0	Aes interrupt status	[0]: encrypt done;[1]: decrypt failed;[2]: decrypt ok;[3] single mode done
0x18 AES reserved register				
[31:0]	—	32'b0	reserved	
0x1C AES reserved register				
[31:0]	—	32'b0	reserved	
0x20 AES key0 register				
[31:0]	RW	32'b0	Key0[31:0]	Key[31:0]
0x24 AES key1 register				
[31:0]	RW	32'b0	Key1[31:0]	Key[63:32]
0x28 AES key2 register				
[31:0]	RW	32'b0	Key2[31:0]	Key[95:64]
0x2C AES key3 register				
[31:0]	RW	32'b0	Key3[31:0]	Key[127:96]

0x30				AES nonce0 register
[31:0]	RW	32'b0	Nonce0[31:0]	Single mode:data_in[31:0];ECB-CCM:Nonce[31:0]
0x34				AES nonce1 register
[31:0]	RW	32'b0	Nonce1[31:0]	Single mode:data_in[31:0];ECB-CCM:Nonce[63:32]
0x38				AES nonce2 register
[31:0]	RW	32'b0	Nonce2[31:0]	Single mode:data_in[31:0];ECB-CCM:Nonce[95:64]
0x3C				AES nonce3 register
[31:0]	RW	32'b0	Nonce3[31:0]	Single mode:data_in[31:0];ECB-CCM:Nonce[127:96]
0x50				AES data out 0(single mode) register
[31:0]	RO	32'b0	Data_o0[31:0]	Data_out[31:0]
0x54				AES data out 1(single mode) register
[31:0]	RO	32'b0	Data_o1[31:0]	Data_out[63:32]
0x58				AES data out 2(single mode) register
[31:0]	RO	32'b0	Data_o2[31:0]	Data_out[95:64]
0x5C				AES data out 3(single mode) register
[31:0]	RO	32'b0	Data_o3[31:0]	Data_out[127:96]
0x100				AES memory (0x0100~0x01FC)
[31:0]	RW	32'b0	memory write	Writing offset address 0x100~0x1FC will write data into aes memory

4.5 Random Number Generator (RNG)

The Random Number Generator (RNG) generates true non-deterministic random numbers based on internal thermal noise. These random numbers are suitable for cryptographic purposes. The RNG does not require a seed value.

4.6 Watchdog Timer (WDT)

A count down watchdog timer using the low-frequency clock source (LFCLK) offers configurable and robust protection against application lock-up. The watchdog can be paused during long CPU sleep periods for low power applications and when the debugger has halted the CPU.

4.7 SPI (SPI)

The SPI interface supports 3 serial synchronous protocols which are SPI, SSP and Microwire serial protocols. SPI wrapper contains one SPI master and one SPI slave. They are logically exclusive. Only one block is alive at a time. The operation mode for master mode and slave mode is controlled by

PERI_MASTER_SELECT Register in COM block.

bit	Reset value	Definition
1	0	SPI1 is master mode when set
0	0	SPIO is master mode when set

**Table 10: PERI_MASTER_SELECT Register bit definition
(base address = 0x4000_302C)**

SPIO and SPI1 configuration registers are listed below:

Base address: SPIO: 4000_6000; SPI1: 4000_7000

0x00		CTRLR0		
[31:16]	RO	16'b0	Reserved	Reserved
[15:12]	RW	4'b0	CFS	Control Frame Size. Selects the length of the control word for the Microwire frame format
[11]	RW	1'b0	SRL	Shift Register Loop. Used for testing purposes only. When internally active, connects the transmit shift register output to the receive shift register input
[10]	RW	1'b0	SLV_OE	Slave Output Enable 1'b0: Slave txd is enabled 1'b1: Slave txd is disabled
[9:8]	RW	2'b0	TMOD	Transfer Mode. Selects the mode of transfer for serial communication. 2'b00: Transmit & Receive 2'b01: Transmit Only 2'b10: Receive Only 2'b11: EEPROM Read
[7]	RW	1'b0	SCPOL	Serial Clock Polarity. Valid when the frame format (FRF) is set to Motorola SPI. Used to select the polarity of the inactive serial clock 1'b0: Inactive state of serial clock is low 1'b1: Inactive state of serial clock is high
[6]	RW	1'b0	SCPH	Serial Clock Phase. Valid when the frame format (FRF) is set to Motorola SPI. The serial clock phase selects the relationship of the serial clock with the slave select signal 1'b0: Serial clock toggles in middle of first data bit 1'b1: Serial clock toggles at start of first data bit
[5:4]	RW	2'b0	FRF	Frame Format. Selects which serial protocol transfers the data 2'b00: Motorola SPI 2'b01: Texas Instruments SSP 2'b10: National Semiconductors Microwire 2'b11: Reserved
[3:0]	RW	4'b0x7	DFS	Data Frame Size. Selects the data frame length
0x04		CTRLR1		
[31:16]	RO	16'b0	Reserved	Reserved
[15:0]	RW	16'b0	NDF	Number of Data Frames
0x08		SSIENR		
[31:1]	RO	31'b0	Reserved	Reserved

[0]	RW	1'b0	SSI_EN	This register enables and disables the DW_apb_ssi 1'b0: disable 1'b1: enable
0x0c			MWCR	
[31:3]	RO	29'b0	Reserved	Reserved
[2]	RW	1'b0	MHS	Microwire Handshaking 1'b0: disabled 1'b1: enabled
[1]	RW	1'b0	MDD	Microwire Control. Defines the direction of the data word when the Microwire serial protocol is used
[0]	RW	1'b0	MWMOD	Microwire Transfer Mode. Defines whether the Microwire transfer is sequential or non-sequential 1'b0: non-sequential transfer 1'b1: sequential transfer
0x10			SER	
[31:1]	RO	31'b0	Reserved	Reserved
[0]	RW	1'b0	SER	Slave Select Enable Flag 1'b0: non-sequential transfer 1'b1: sequential transfer
0x14			BAUDR	
[31:16]	RO	16'b0	Reserved	Reserved
[15:0]	RW	16'b0	SCKDV	SSI Clock Divider
0x18			TXFTLR	
[31:3]	RO	29'b0	Reserved	Reserved
[2:0]	RW	3'b0	TFT	Transmit FIFO Threshold. Controls the level of entries (or below) at which the transmit FIFO controller triggers an interrupt
0x1c			RXFTLR	
[31:3]	RO	29'b0	Reserved	Reserved
[2:0]	RW	3'b0	RFT	Receive FIFO Threshold. Controls the level of entries (or above) at which the receive FIFO controller triggers an interrupt
0x20			TXFLR	
[31:4]	RO	28'b0	Reserved	Reserved
[3:0]	RO	4'b0	TXTFL	Transmit FIFO Level. Contains the number of valid data entries in the transmit FIFO
0x24			RXFLR	
[31:4]	RO	28'b0	Reserved	Reserved
[3:0]	RO	4'b0	RXTFL	Receive FIFO Level. Contains the number of valid data entries in the receive FIFO
0x28			SR	
[31:7]	RO	25'b0	Reserved	Reserved
[6]	RO	1'b0	DCOL	Data Collision Error 1'b0: No error 1'b1: Transmit data collision error
[5]	RO	1'b0	TXE	Transmission Error. Set if the transmit FIFO is empty when a transfer is started 1'b0: No error 1'b1: Transmission error

[4]	RO	1'b0	RFF	Receive FIFO Full 1'b0: not full 1'b1: full
[3]	RO	1'b0	RFNE	Receive FIFO Not Empty 1'b0: empty 1'b1: not empty
[2]	RO	1'b1	TFE	Transmit FIFO Empty 1'b0: not empty 1'b1: empty
[1]	RO	1'b1	TFNF	Transmit FIFO Not Full 1'b0: full 1'b1: not full
[0]	RO	1'b0	BUSY	SSI Busy Flag 1'b0: DW_apb_ssi is idle or disabled 1'b1: DW_apb_ssi is actively transferring data

0x2c IMR

[31:6]	RO	26'b0	Reserved	Reserved
[5]	RW	1'b1	MSTIM	Multi-Master Contention Interrupt Mask 1'b0: masked 1'b1: not masked
[4]	RW	1'b1	RXFIM	Receive FIFO Full Interrupt Mask 1'b0: masked 1'b1: not masked
[3]	RW	1'b1	RXOIM	Receive FIFO Overflow Interrupt Mask 1'b0: masked 1'b1: not masked
[2]	RW	1'b1	RXUIM	Receive FIFO Underflow Interrupt Mask 1'b0: masked 1'b1: not masked
[1]	RW	1'b1	TXOIM	Transmit FIFO Overflow Interrupt Mask 1'b0: masked 1'b1: not masked
[0]	RW	1'b1	TXEIM	Transmit FIFO Empty Interrupt Mask 1'b0: masked 1'b1: not masked

0x30 ISR

[31:6]	RO	26'b0	Reserved	Reserved
[5]	RO	1'b0	MSTIS	Multi-Master Contention Interrupt Status 1'b0: not active 1'b1: active
[4]	RO	1'b0	RXFIS	Receive FIFO Full Interrupt Status 1'b0: not active 1'b1: active
[3]	RO	1'b0	RXOIS	Receive FIFO Overflow Interrupt Status 1'b0: not active 1'b1: active
[2]	RO	1'b0	RXUIS	Receive FIFO Underflow Interrupt Status 1'b0: not active 1'b1: active
[1]	RO	1'b0	TXOIS	Transmit FIFO Overflow Interrupt Status 1'b0: not active 1'b1: active

[0]	RO	1'b0	TXEIS	Transmit FIFO Empty Interrupt Status 1'b0: not active 1'b1: active
0x34			RISR	
[31:6]	RO	26'b0	Reserved	Reserved
[5]	RO	1'b0	MSTIR	Multi-Master Contention Raw Interrupt Status 1'b0: not active 1'b1: active
[4]	RO	1'b0	RXFIR	Receive FIFO Full Raw Interrupt Status 1'b0: not active 1'b1: active
[3]	RO	1'b0	RXOIR	Receive FIFO Overflow Raw Interrupt Status 1'b0: not active 1'b1: active
[2]	RO	1'b0	RXUIR	Receive FIFO Underflow Raw Interrupt Status 1'b0: not active 1'b1: active
[1]	RO	1'b0	TXOIR	Transmit FIFO Overflow Raw Interrupt Status 1'b0: not active 1'b1: active
[0]	RO	1'b0	TXEIR	Transmit FIFO Empty Raw Interrupt Status 1'b0: not active 1'b1: active
0x38			TXOICR	
[31:1]	RO	31'b0	Reserved	Reserved
[0]	RO	1'b0	TXOICR	Clear Transmit FIFO Overflow Interrupt
0x3c			RXOICR	
[31:1]	RO	31'b0	Reserved	Reserved
[0]	RO	1'b0	RXOICR	Clear Receive FIFO Overflow Interrupt
0x40			RXUICR	
[31:1]	RO	31'b0	Reserved	Reserved
[0]	RO	1'b0	RXUICR	Clear Receive FIFO Underflow Interrupt
0x44			MSTICR	
[31:1]	RO	31'b0	Reserved	Reserved
[0]	RO	1'b0	MSTICR	Clear Multi-Master Contention Interrupt
0x48			ICR	
[31:1]	RO	31'b0	Reserved	Reserved
[0]	RO	1'b0	ICR	Clear Interrupts
0x4c			DMACR	
[31:2]	RO	30'b0	Reserved	Reserved
[1]	RW	1'b0	TDMAE	Transmit DMA Enable. This bit enables/disables the transmit FIFO DMA channel 1'b0: disable 1'b1: enable
[0]	RW	1'b0	RDMAE	Receive DMA Enable. This bit enables/disables the receive FIFO DMA channel 1'b0: disable 1'b1: enable
0x50			DMATDLR	

[31:3]	RO	29'b0	Reserved	Reserved
[2:0]	RW	3'b0	DMATDL	Transmit Data Level
0x54			DMARDLR	
[31:3]	RO	29'b0	Reserved	Reserved
[2:0]	RW	3'b0	DMARDL	Receive Data Level
0x58			IDR	
[31:0]	RO	32'b0	IDCODE	Identification Code
0x5c			SSI_COMP_VERSION	
[31:0]	RO	32'b0	SSI_COMP_VERSION	Contains the hex representation of the Synopsys component version
0x60~0x9c			DR	
[31:16]	RO	16'b0	Reserved	Reserved
[15:0]	RW	16'b0	DR	Data Register Read: Receive FIFO buffer Write: Transmit FIFO buffer
0xf4			RSVD_0	
[31:0]	RW	32'b0	Reserved	Reserved location for future use
0xf8			RSVD_1	
[31:0]	RW	32'b0	Reserved	Reserved location for future use
0xfc			RX_SAMPLE_DLY	
[31:8]	RO	24'b0	Reserved	Reserved
[7:0]	RW	8'b0	RSD	Receive Data (rxd) Sample Delay. This register is used to delay the sample of the rxd input signal

4.8 I2C (I2c0, I2c1 Two Independent Instances)

This I2C block support 100Khz, and 400Khz modes. It also supports 7-bit address and 10-bit address. It has built-in configurable spike suppression function for both lines.

I2C registers are listed below:

Base address: I2C0: 4000_5000, I2C1: 4000_5800

OFFSET	TYPE	RESET	NAME	DESCRIPTION
0x00			I2C Control Register	
[31:7]	RO	25'b0	Reserved	Reserved
[6]	RW	1'b0	IC_SLAVE_DISABLE	This bit controls whether I2C has its slave disabled 1'b0: slave is enabled 1'b1: slave is disabled
[5]	RW	1'b1	IC_RESTART_EN	Determines whether RESTART conditions may be sent when acting as a master 1'b0: disable 1'b1: enable
[4]	RW	1'b1	IC_10BITADDR_MASTER	Controls whether the DW_apb_i2c starts its transfers in 7- or 10-bit addressing mode when acting as a master 1'b0: 7-bit addressing 1'b1: 10-bit addressing

[3]	RW	1'b1	IC_10BITADDR_SLAVE	When acting as a slave, this bit controls whether the DW_apb_i2c responds to 7- or 10-bit addresses 1'b0: 7-bit addressing 1'b1: 10-bit addressing
[2:1]	RW	2'b11	SPEED	These bits control at which speed the DW_apb_i2c operates 2'b01: standard mode 2'b10: fast mode 2'b11: high speed mode
[0]	RW	1'b0	MASTER_MODE	This bit controls whether the DW_apb_i2c master is enabled 1'b0: enable 1'b1: disable
0x04			I2C Target Address Register	
[31:13]	RO	19'b0	Reserved	Reserved
[12]	RW	1'b1	IC_10BITADDR_MASTER	This bit controls whether the DW_apb_i2c starts its transfers in 7-or 10-bit addressing mode when acting as a master 1'b0: 7-bit addressing 1'b1: 10-bit addressing
[11]	RW	1'b0	SPECIAL	This bit indicates whether software performs a General Call or START BYTE command 1'b0: ignore bit 10 GC_OR_START and use IC_TAR normally 1'b1: perform special I2C command as specified in GC_OR_START bit
[10]	RW	1'b0	GC_OR_START	If bit 11 (SPECIAL) is set to 1, then this bit indicates whether a General Call or START byte command is to be performed by the DW_apb_i2c 1'b0: General Call Address 1'b1: START BYTE
[9:0]	RW	10'b0x055	IC_TAR	This is the target address for any master transaction
0x08			IC_SAR	
[31:10]	RO	22'b0	Reserved	Reserved
[9:0]	RW	10'b0x055	IC_SAR	The IC_SAR holds the slave address when the I2C is operating as a slave. For 7-bit addressing, only IC_SAR[6:0] is used
0x0c			IC_HS_MADDR	
[31:3]	RO	29'b0	Reserved	Reserved
[2:0]	RW	3'b1	IC_HS_MAR	This bit field holds the value of the I2C HS mode master code
0x10			IC_DATA_CMD	
[31:11]	RO	21'b0	Reserved	Reserved
[10]	WO	1'b0	RESTART	This bit controls whether a RESTART is issued before the byte is sent or received. This bit is available only if IC_EMPTYFIFO_HOLD_MASTER_EN is configured to 1
[9]	WO	1'b0	STOP	This bit controls whether a STOP is issued after the byte is sent or received. This bit is available only if

				IC_EMPTYFIFO_HOLD_MASTER_EN is configured to 1
[8]	WO	1'b0	CMD	This bit controls whether a read or a write is performed 1'b0: Read 1'b1: Write
[7:0]	RW	8'b0	DAT	This register contains the data to be transmitted or received on the I2C bus
0x14			IC_SS_SCL_HCNT	
[31:16]	RO	16'b0	Reserved	Reserved
[15:0]	RW	16'b0	IC_SS_SCL_HCNT	This register must be set before any I2C bus transaction can take place to ensure proper I/O timing. This register sets the SCL clock high-period count for standard speed
0x18			IC_SS_SCL_LCNT	
[31:16]	RO	16'b0	Reserved	Reserved
[15:0]	RW	16'b0	IC_SS_SCL_LCNT	This register must be set before any I2C bus transaction can take place to ensure proper I/O timing. This register sets the SCL clock low period count for standard speed
0x1c			IC_FS_SCL_HCNT	
[31:16]	RO	16'b0	Reserved	Reserved
[15:0]	RW	16'b0	IC_FS_SCL_HCNT	This register must be set before any I2C bus transaction can take place to ensure proper I/O timing. This register sets the SCL clock high-period count for fast speed
0x20			IC_FS_SCL_LCNT	
[31:16]	RO	16'b0	Reserved	Reserved
[15:0]	RW	16'b0	IC_FS_SCL_LCNT	This register must be set before any I2C bus transaction can take place to ensure proper I/O timing. This register sets the SCL clock low-period count for fast speed
0x24			IC_HS_SCL_HCNT	
[31:16]	RO	16'b0	Reserved	Reserved
[15:0]	RW	16'b0	IC_HS_SCL_HCNT	This register must be set before any I2C bus transaction can take place to ensure proper I/O timing. This register sets the SCL clock high period count for high speed
0x28			IC_HS_SCL_LCNT	
[31:16]	RO	16'b0	Reserved	Reserved
[15:0]	RW	16'b0	IC_HS_SCL_LCNT	This register must be set before any I2C bus transaction can take place to ensure proper I/O timing. This register sets the SCL clock low period count for high speed
0x2c			IC_INTR_STAT	
[31:12]	RO	20'b0	Reserved	Reserved
[11]	RO	1'b0	R_GEN_CALL	Set only when a General Call address is received and it is acknowledged

[10]	RO	1'b0	R_START_DET	Indicates whether a START or RESTART condition has occurred on the I2C interface
[9]	RO	1'b0	R_STOP_DET	Indicates whether a STOP condition has occurred on the I2C interface
[8]	RO	1'b0	R_ACTIVITY	This bit captures DW_apb_i2c activity and stays set until it is cleared
[7]	RO	1'b0	R_RX_DONE	When the DW_apb_i2c is acting as a slave-transmitter, this bit is set to 1 if the master does not acknowledge a transmitted byte
[6]	RO	1'b0	R_TX_ABRT	This bit indicates if DW_apb_i2c, as an I2C transmitter, is unable to complete the intended actions on the contents of the transmit FIFO
[5]	RO	1'b0	R_RD_REQ	This bit is set to 1 when DW_apb_i2c is acting as a slave and another I2C master is attempting to read data from DW_apb_i2c
[4]	RO	1'b0	R_TX_EMPTY	This bit is set to 1 when the transmit buffer is at or below the threshold value set in the IC_TX_TL register
[3]	RO	1'b0	R_TX_OVER	Set during transmit if the transmit buffer is filled to IC_TX_BUFFER_DEPTH and the processor attempts to issue another I2C command by writing to the IC_DATA_CMD register
[2]	RO	1'b0	R_RX_FULL	Set when the receive buffer reaches or goes above the RX_TL threshold in the IC_RX_TL register
[1]	RO	1'b0	R_RX_OVER	Set if the receive buffer is completely filled to IC_RX_BUFFER_DEPTH and an additional byte is received from an external I2C device
[0]	RO	1'b0	R_RX_UNDER	Set if the processor attempts to read the receive buffer when it is empty by reading from the IC_DATA_CMD register

0x30		IC_INTR_MASK		
[31:12]	RW	20'b0	Reserved	Reserved
[11]	RW	1'b1	R_GEN_CALL	mask R_GEN_CALL interrupt status bits
[10]	RW	1'b0	R_START_DET	mask R_START_DET interrupt status bits
[9]	RW	1'b0	R_STOP_DET	mask R_STOP_DET interrupt status bits
[8]	RW	1'b0	R_ACTIVITY	mask R_ACTIVITY interrupt status bits
[7]	RW	1'b1	R_RX_DONE	mask R_RX_DONE interrupt status bits
[6]	RW	1'b1	R_TX_ABRT	mask R_TX_ABRT interrupt status bits
[5]	RW	1'b1	R_RD_REQ	mask R_RD_REQ interrupt status bits
[4]	RW	1'b1	R_TX_EMPTY	mask R_TX_EMPTY interrupt status bits
[3]	RW	1'b1	R_TX_OVER	mask R_TX_OVER interrupt status bits
[2]	RW	1'b1	R_RX_FULL	mask R_RX_FULL interrupt status bits

[1]	RW	1'b1	R_RX_OVER	mask R_RX_OVER interrupt status bits
[0]	RW	1'b1	R_RX_UNDER	mask R_RX_UNDER interrupt status bits
0x34			IC_RAW_INTR_STAT	
[31:12]	RO	20'b0	Reserved	Reserved
[11]	RO	1'b0	GEN_CALL	Set only when a General Call address is received and it is acknowledged
[10]	RO	1'b0	START_DET	Indicates whether a START or RESTART condition has occurred on the I2C interface
[9]	RO	1'b0	STOP_DET	Indicates whether a STOP condition has occurred on the I2C interface
[8]	RO	1'b0	ACTIVITY	This bit captures DW_apb_i2c activity and stays set until it is cleared
[7]	RO	1'b0	RX_DONE	When the DW_apb_i2c is acting as a slave-transmitter, this bit is set to 1 if the master does not acknowledge a transmitted byte
[6]	RO	1'b0	TX_ABRT	This bit indicates if DW_apb_i2c, as an I2C transmitter, is unable to complete the intended actions on the contents of the transmit FIFO
[5]	RO	1'b0	RD_REQ	This bit is set to 1 when DW_apb_i2c is acting as a slave and another I2C master is attempting to read data from DW_apb_i2c
[4]	RO	1'b0	TX_EMPTY	This bit is set to 1 when the transmit buffer is at or below the threshold value set in the IC_TX_TL register
[3]	RO	1'b0	TX_OVER	Set during transmit if the transmit buffer is filled to IC_TX_BUFFER_DEPTH and the processor attempts to issue another I2C command by writing to the IC_DATA_CMD register
[2]	RO	1'b0	RX_FULL	Set when the receive buffer reaches or goes above the RX_TL threshold in the IC_RX_TL register
[1]	RO	1'b0	RX_OVER	Set if the receive buffer is completely filled to IC_RX_BUFFER_DEPTH and an additional byte is received from an external I2C device
[0]	RO	1'b0	RX_UNDER	Set if the processor attempts to read the receive buffer when it is empty by reading from the IC_DATA_CMD register
0x38			IC_RX_TL	
[31:8]	RO	24'b0	Reserved	Reserved
[7:0]	RW	8'b0	RX_TL	Receive FIFO Threshold Level
0x3c			IC_TX_TL	
[31:8]	RO	24'b0	Reserved	Reserved
[7:0]	RW	8'b0	TX_TL	Transmit FIFO Threshold Level
0x40			IC_CLR_INTR	
[31:1]	RO	31'b0	Reserved	Reserved

[0]	RO	1'b0	CLR_INTR	Read this register to clear the combined interrupt, all individual interrupts, and the IC_TX_ABRT_SOURCE register
0x44 IC_CLR_RX_UNDER				
[31:1]	RO	31'b0	Reserved	Reserved
[0]	RO	1'b0	CLR_RX_UNDER	Read this register to clear the RX_UNDER interrupt (bit 0) of the IC_RAW_INTR_STAT register
0x48 IC_CLR_RX_OVER				
[31:1]	RO	31'b0	Reserved	Reserved
[0]	RO	1'b0	CLR_RX_OVER	Read this register to clear the RX_OVER interrupt (bit 1) of the IC_RAW_INTR_STAT register
0x4c IC_CLR_TX_OVER				
[31:1]	RO	31'b0	Reserved	Reserved
[0]	RO	1'b0	CLR_TX_OVER	Read this register to clear the TX_OVER interrupt (bit 3) of the IC_RAW_INTR_STAT register
0x50 IC_CLR_RD_REQ				
[31:1]	RO	31'b0	Reserved	Reserved
[0]	RO	1'b0	CLR_RD_REQ	Read this register to clear the RD_REQ interrupt (bit 5) of the IC_RAW_INTR_STAT register
0x54 IC_CLR_TX_ABRT				
[31:1]	RO	31'b0	Reserved	Reserved
[0]	RO	1'b0	CLR_TX_ABRT	Read this register to clear the TX_ABRT interrupt (bit 6) of the IC_RAW_INTR_STAT register, and the IC_TX_ABRT_SOURCE register
0x58 IC_CLR_RX_DONE				
[31:1]	RO	31'b0	Reserved	Reserved
[0]	RO	1'b0	CLR_RX_DONE	Read this register to clear the RX_DONE interrupt (bit 7) of the IC_RAW_INTR_STAT register
0x5c IC_CLR_ACTIVITY				
[31:1]	RO	31'b0	Reserved	Reserved
[0]	RO	1'b0	CLR_ACTIVITY	Reading this register clears the ACTIVITY interrupt if the I2C is not active anymore. If the I2C module is still active on the bus, the ACTIVITY interrupt bit continues to be set
0x60 IC_CLR_STOP_DET				
[31:1]	RO	31'b0	Reserved	Reserved
[0]	RO	1'b0	CLR_STOP_DET	Read this register to clear the STOP_DET interrupt (bit 9) of the IC_RAW_INTR_STAT register
0x64 IC_CLR_START_DET				
[31:1]	RO	31'b0	Reserved	Reserved
[0]	RO	1'b0	CLR_START_DET	Read this register to clear the START_DET interrupt (bit 10) of the IC_RAW_INTR_STAT register

0x68		IC_CLR_GEN_CALL		
[31:1]	RO	31'b0	Reserved	Reserved
[0]	RO	1'b0	CLR_GEN_CALL	Read this register to clear the GEN_CALL interrupt (bit 11) of IC_RAW_INTR_STAT register
0x6c		IC_ENABLE		
[31:2]	RO	30'b0	Reserved	Reserved
[1]	RW	1'b0	ABORT	When set, the controller initiates the transfer abort 1'b0: ABORT not initiated or ABORT done 1'b1: ABORT operation in progress
[0]	RW	1'b0	ENABLE	Controls whether the DW_apb_i2c is enabled 1'b0: disable 1'b1: enable
0x70		IC_STATUS		
[31:7]	RO	25'b0	Reserved	Reserved
[6]	RO	1'b0	SLV_ACTIVITY	Slave FSM Activity Status 1'b0: in IDLE state 1'b1: not in IDLE state
[5]	RO	1'b0	MST_ACTIVITY	Master FSM Activity Status 1'b0: in IDLE state 1'b1: not in IDLE state
[4]	RO	1'b0	RFF	Receive FIFO Completely Full 1'b0: not full 1'b1: full
[3]	RO	1'b0	RFNE	Receive FIFO Not Empty 1'b0: empty 1'b1: not empty
[2]	RO	1'b1	TFE	Transmit FIFO Completely Empty 1'b0: not empty 1'b1: empty
[1]	RO	1'b1	TFNF	Transmit FIFO Not Full 1'b0: full 1'b1: not full
[0]	RO	1'b0	ACTIVITY	I2C Activity Status
0x74		IC_TXFLR		
[31:4]	RO	28'b0	Reserved	Reserved
[3:0]	RO	4'b0	TXFLR	Transmit FIFO Level. Contains the number of valid data entries in the transmit FIFO
0x78		IC_RXFLR		
[31:4]	RO	28'b0	Reserved	Reserved
[3:0]	RO	4'b0	RXFLR	Receive FIFO Level. Contains the number of valid data entries in the receive FIFO
0x7c		IC_RXFLR		
[31:16]	RO	16'b0	Reserved	Reserved
[15:0]	RW	16'b1	IC_SDA_HOLD	Sets the required SDA hold time in units of ic_clk period
0x80		IC_TX_ABRT_SOURCE		

[31:24]	RO	8'b0	TX_FLUSH_CNT	This field preserves the TXFLR value prior to the last TX_ABORT event
[23:17]	RO	7'b0	Reserved	Reserved
[16]	RO	1'b0	ABRT_USER_ABORT	This is a master-mode-only bit. Master has detected the transfer abort (IC_ENABLE[1])
[15]	RO	1'b0	ABRT_SLVRD_INTX	When the processor side responds to a slave mode request for data to be transmitted to a remote master and user writes a 1 in CMD (bit 8) of IC_DATA_CMD register
[14]	RO	1'b0	ABRT_SLV_ARBLOST	Slave lost the bus while transmitting data to a remote master
[13]	RO	1'b0	ABRT_SLVFLUSH_TXFIFO	Slave has received a read command and some data exists in the TX FIFO so the slave issues a TX_ABORT interrupt to flush old data in TX FIFO
[12]	RO	1'b0	ARB_LOST	Master has lost arbitration, or if IC_TX_ABORT_SOURCE[14] is also set, then the slave transmitter has lost arbitration
[11]	RO	1'b0	ABRT_MASTER_DIS	User tries to initiate a Master operation with the Master mode disabled
[10]	RO	1'b0	ABRT_10B_RD_NORSTR	The restart is disabled(IC_RESTART_EN bit (IC_CON[5]) = 0) and the master sends a read command in 10-bit addressing mode
[9]	RO	1'b0	ABRT_SBYTE_NORSTR	The restart is disabled (IC_RESTART_EN bit (IC_CON[5]) = 0) and the user is trying to send a START Byte
[8]	RO	1'b0	ABRT_HS_NORSTR	The restart is disabled(IC_RESTART_EN bit (IC_CON[5]) = 0) and the user is trying to use the master to transfer data in High Speed mode
[7]	RO	1'b0	ABRT_SBYTE_ACKDET	Master has sent a START Byte and the START Byte was acknowledged (wrong behavior)
[6]	RO	1'b0	ABRT_HS_ACKDET	Master is in High Speed mode and the High Speed Master code was acknowledged (wrong behavior)
[5]	RO	1'b0	ABRT_GCALL_READ	DW_apb_i2c in master mode sent a General Call but the user programmed the byte following the General Call to be a read from the bus (IC_DATA_CMD[9] is set to 1)
[4]	RO	1'b0	ABRT_GCALL_NOACK	DW_apb_i2c in master mode sent a General Call and no slave on the bus acknowledged the General Call
[3]	RO	1'b0	ABRT_TXDATA_NOACK	This is a master-mode only bit. Master has received an acknowledgement for the address, but when it sent data byte(s) following the address, it did not receive an acknowledge from the remote slave(s)
[2]	RO	1'b0	ABRT_10ADDR2_NOACK	Master is in 10-bit address mode and the second address byte of the 10-bit address was not acknowledged by any

				slave
[1]	RO	1'b0	ABRT_10ADDR1_NOACK	Master is in 10-bit address mode and the first 10-bit address byte was not acknowledged by any slave
[0]	RO	1'b0	ABRT_7B_ADDR_NOACK	Master is in 7-bit addressing mode and the address sent was not acknowledged by any slave
0x84			IC_SLV_DATA_NACK_ONLY	
[31:1]	RO	31'b0	Reserved	Reserved
[0]	RW	1'b0	NACK	Generate NACK 1'b0: generate NACK after data byte received 1'b1: generate NACK/ACK normally
0x88			IC_DMA_CR	
[31:2]	RO	30'b0	Reserved	Reserved
[1]	RW	1'b0	TDMAE	Transmit DMA Enable 1'b0: disable 1'b1: enable
[0]	RW	1'b0	RDMAE	Receive DMA Enable 1'b0: disable 1'b1: enable
0x8c			IC_DMA_TDLR	
[31:3]	RO	29'b0	Reserved	Reserved
[2:0]	RW	3'b0	DMATDL	Transmit Data Level
0x90			IC_DMA_RDLR	
[31:3]	RO	29'b0	Reserved	Reserved
[2:0]	RW	3'b0	DMARDL	Receive Data Level
0x94			IC_SDA_SETUP	
[31:8]	RO	24'b0	Reserved	Reserved
[7:0]	RW	8'b0x64	SDA_SETUP	SDA Setup
0x98			IC_ACK_GENERAL_CALL	
[31:1]	RO	31'b0	Reserved	Reserved
[0]	RW	1'b1	ACK_GEN_CALL	ACK General Call
0x9c			IC_ENABLE_STATUS	
[31:3]	RO	31'b0	Reserved	Reserved
[2]	RO	1'b0	SLV_RX_DATA_LOST	Slave Received Data Lost
[1]	RO	1'b0	SLV_DISABLED_WHILE_BUSY	Slave Disabled While Busy (Transmit, Receive)
[0]	RO	1'b0	IC_EN	ic_en Status 1'b0: DW_apb_i2c is deemed completely inactive 1'b1: DW_apb_i2c is deemed to be in an enabled state
0xa0			IC_FS_SPKLEN	
[31:8]	RO	24'b0	Reserved	Reserved
[7:0]	RW	8'b0xff	IC_FS_SPKLEN	This register must be set before any I2C bus transaction can take place to ensure stable operation
0xa4			IC_HS_SPKLEN	

[31:8]	RO	24'b0	Reserved	Reserved
[7:0]	RW	8'b0xff	IC_HS_SPKLEN	This register must be set before any I2C bus transaction can take place to ensure stable operation
0xf4			IC_COMP_PARAM_1	
[31:24]	RO	8'b0	Reserved	Reserved
[23:16]	RO	8'b0	TX_BUFFER_DEPTH	The value of this register is derived from the IC_TX_BUFFER_DEPTH coreConsultant parameter 8'b0x00: Reserved 8'b0x01: 2 8'b0x02: 3 ... 8'b0xff: 256
[15:8]	RO	8'b0	RX_BUFFER_DEPTH	The value of this register is derived from the IC_RX_BUFFER_DEPTH coreConsultant parameter. For a description of this parameter 8'b0x00: Reserved 8'b0x01: 2 8'b0x02: 3 ... 8'b0xff: 256
[7]	RO	1'b0	ADD_ENCODED_PARAMS	The value of this register is derived from the IC_ADD_ENCODED_PARAMS coreConsultant parameter. 1'b0: False 1'b1: True
[6]	RO	1'b0	HAS_DMA	The value of this register is derived from the IC_HAS_DMA coreConsultant parameter 1'b0: False 1'b1: True
[5]	RO	1'b0	INTR_IO	The value of this register is derived from the IC_INTR_IO coreConsultant parameter 1'b0: Individual 1'b1: Combined
[4]	RO	1'b0	HC_COUNT_VALUES	The value of this register is derived from the IC_HC_COUNT_VALUES coreConsultant parameter 1'b0: False 1'b1: True
[3:2]	RO	2'b0	MAX_SPEED_MODE	The value of this register is derived from the IC_MAX_SPEED_MODE coreConsultant parameter 2'b00: Reserved 2'b01: Standard 2'b10: Fast 2'b11: High
[1:0]	RO	2'b0	APB_DATA_WIDTH	The value of this register is derived from the APB_DATA_WIDTH coreConsultant parameter 2'b00: 8 bits 2'b01: 16 bits 2'b10: 32 bits 2'b11: Reserved

0xf8			IC_COMP_VERSION	
[31:0]	RO	32'b0	IC_COMP_VERSION	Specific values for this register are described in the Releases Table in the AMBA 2 release notes
0xfc			IC_COMP_TYPE	
[31:0]	RO	32'b0	IC_COMP_TYPE	This assigned unique hex value is constant and is derived from the two ASCII letters "DW" followed by a 16-bit unsigned number

4.9 I2S

I2S wrapper contains one I2S master and one I2S slave. They are logically exclusive. Only one block is alive at a time. The operation mode for master mode and slave mode is controlled by PERI_MASTER_SELECT Register in COM block.

bit	Reset value	Definition
3	0	I2S1 is master mode when set
2	0	I2S0 is master mode when set

Table 11: PERI_MASTER_SELECT Register bit definition (base address = 0x4002_302C)

I2S registers are listed below:

Base address: 4000_9000

0x00			IER	
[31:1]	RO	31'b0	Reserved	Reserved
[0]	RW	1'b0	IEN	DW_apb_i2s enable 1'b0: disable 1'b1: enable
0x04			IRER	
[31:1]	RO	31'b0	Reserved	Reserved
[0]	RW	1'b0	RXEN	Receiver block enable 1'b0: disable 1'b1: enable
0x08			ITER	
[31:1]	RO	31'b0	Reserved	Reserved
[0]	RW	1'b0	TXEN	Transmitter block enable 1'b0: disable 1'b1: enable
0x0c			CER	
[31:1]	RO	31'b0	Reserved	Reserved
[0]	RW	1'b0	CLKEN	Clock generation enable/disable 1'b0: disable 1'b1: enable
0x10			CCR	
[31:5]	RO	27'b0	Reserved	Reserved

[4:3]	RW	2'b00	WSS	These bits are used to program the number of sclk cycles for which the world select line(ws_out) stays in the left or right sample mode 2'b00: 16 clock cycles 2'b01: 24 clock cycles 2'b10: 32 clock cycles
[2:0]	RW	3'b0	SCLKG	These bits are used to program the gating of sclk 3'b000: No clock gating 3'b001: Gate after 12 clock cycles 3'b010: Gate after 16 clock cycles 3'b011: Gate after 20 clock cycles 3'b100: Gate after 24 clock cycles
0x14			RXFFR	
[31:1]	RO	31'b0	Reserved	Reserved
[0]	WO	1'b0	RXFFR	Receiver FIFO Reset;Receiver Block must be disabled prior to writing this bit
0x18			TXFFR	
[31:1]	RO	31'b0	Reserved	Reserved
[0]	WO	1'b0	TXFFR	Transmitter FIFO Reset;Transmitter Block must be disabled prior to writing this bit
0x20			LRBR0	
[31:16]	RO	16'b0	Reserved	Reserved
[15:0]	RO	16'b0	LRBR0	The left stereo data received serially from the receive channel input is read through this register
0x20			LTHR0	
[31:16]	RO	16'b0	Reserved	Reserved
[15:0]	WO	16'b0	LTHR0	The left stereo to be transmitted serially through the transmit channel output is written through this register
0x24			RRBR0	
[31:16]	RO	16'b0	Reserved	Reserved
[15:0]	RO	16'b0	RRBR0	The right stereo data received serially from the receive channel input is read through this register
0x24			RTHR0	
[31:16]	RO	16'b0	Reserved	Reserved
[15:0]	WO	16'b0	RTHR0	The right stereo to be transmitted serially through the transmit channel output is written through this register
0x28			RER0	
[31:1]	RO	31'b0	Reserved	Reserved
[0]	RW	1'b1	RXCHEN0	Receive channel enable 1'b0: disable 1'b1: enable
0x2c			TER0	
[31:1]	RO	31'b0	Reserved	Reserved
[0]	RW	1'b1	TXCHEN0	Transmit channel enable 1'b0: disable 1'b1: enable

0x30				RCR0
[31:3]	RO	29'b0	Reserved	Reserved These bits are used to program the desired data resolution of the receiver and enables the LSB of the incoming left (or right) word to be placed in the LSB of the LRBR0(or RRBE0) register
[2:0]	RW	3'b010	WLEN	3'b000: Ignore word length 3'b001: 12 bit resolution 3'b010: 16 bit resolution 3'b011: 20 bit resolution 3'b100: 24 bit resolution 3'b101: 32 bit resolution
0x34				TCR0
[31:3]	RO	29'b0	Reserved	Reserved These bits are used to program the data resolution of the transmitter and ensure the MSB of the data is transmitted first
[2:0]	RW	3'b010	WLEN	3'b000: Ignore word length 3'b001: 12 bit resolution 3'b010: 16 bit resolution 3'b011: 20 bit resolution 3'b100: 24 bit resolution 3'b101: 32 bit resolution
0x38				ISR0
[31:6]	RO	26'b0	Reserved	Reserved
[5]	RO	1'b0	TXFO	Status of Data Overrun interrupt for the TX channel 1'b0: TX FIFO write valid 1'b1: TX FIFO write overrun
[4]	RO	1'b1	TXFE	Status of Transmit Empty Trigger interrupt 1'b0: trigger level not reached 1'b1: trigger level reached
[3:2]	RO	2'b0	Reserved	Reserved
[1]	RO	1'b0	RXFO	Status of Data Overrun interrupt for the RX channel 1'b0: RX FIFO write valid 1'b1: RX FIFO write overrun
[0]	RO	1'b0	RXDA	Status of Receive Data Available interrupt 1'b0: trigger level not reached 1'b1: trigger level reached
0x3c				IMR0
[31:6]	RO	26'b0	Reserved	Reserved
[5]	RW	1'b1	TXFOM	Masks TX FIFO Overrun interrupt 1'b0: unmask interrupt 1'b1: mask interrupt
[4]	RW	1'b1	TXFEM	Masks TX FIFO Empty interrupt 1'b0: unmask interrupt 1'b1: mask interrupt
[3:2]	RO	2'b0	Reserved	Reserved
[1]	RW	1'b1	RXFOM	Masks RX FIFO Overrun interrupt 1'b0: unmask interrupt 1'b1: mask interrupt

[0]	RW	1'b1	RXDAM	Masks RX FIFO Data Available interrupt 1'b0: unmasks interrupt 1'b1: masks interrupt
0x40				
[31:1]	RO	31'b0	Reserved	Reserved
[0]	RO	1'b1	RXCHO	Read this bit to clear the RX FIFO Data Overrun interrupt 1'b0: RX FIFO write valid 1'b1: RX FIFO write overrun
0x44				
[31:1]	RO	31'b0	Reserved	Reserved
[0]	RO	1'b1	TXCHO	Read this bit to clear the TX FIFO Data Overrun interrupt 1'b0: TX FIFO write valid 1'b1: TX FIFO write overrun
0x48				
[31:4]	RO	29'b0	Reserved	Reserved
[3:0]	RW	3'b011	RXCHDT	These bits program the trigger level in the RX FIFO at which the Received Data Available interrupt is generated
0x4c				
[31:4]	RO	29'b0	Reserved	Reserved
[3:0]	RW	3'b011	TXCHET	Transmit Channel Empty Trigger;These bits program the trigger level in the TX FIFO at which the Empty Threshold Reached interrupt is generated
0x50				
[31:1]	RO	31'b0	Reserved	Reserved
[0]	WO	1'b0	RXCHFR	Receive Channel FIFO Reset;Writing a 1 to this register flushes an individual RX FIFO,Rx channel or block must be disabled prior to writing this bit
0x54				
[31:1]	RO	31'b0	Reserved	Reserved
[0]	WO	1'b0	TXCHFR	Transmit Channel FIFO Reset;Writing a 1 to this register flushes channel's TX FIFO,Tx channel or block must be disabled prior to writing this bit
0x1c0				
[31:0]	RO	32'b0	RXDMA	Receiver Block DMA Register.Used to cycle repeatedly through the enabled receive channels(from lowest numbered to highest),reading stereo data pairs
0x1c4				
[31:1]	RO	31'b0	Reserved	Reserved
[0]	WO	1'b0	RRXDMA	Reset Receiver Block DMA Register.Writing a 1 to this self-clearing register reset the RXDMA register mid-cycle to point to the lowest enabled Receive channel
0x1c8				
[31:0]	RO	32'b0	TXDMA	Transmitter Block DMA Register.Used to cycle repeatedly through the enabled

receive channels(from lowest numbered to highest),reading stereo data pairs

0x1cc		RTXDMA		
[31:1]	RO	31'b0	Reserved	Reserved
[0]	WO	1'b0	RTXDMA	Reset Transmitter Block DMA Register.Writing a 1 to this self-clearing register reset the TXDMA register mid-cycle to point to the lowest enabled Receive channel
0x1f0		I2S_COMP_PARAM_2		
[31:13]	RO	19'b0	Reserved	Reserved
[12:10]	RO	3'b0	I2S_RX_WORDSIZE_3	3'b000: 12 bit resolution 3'b001: 16 bit resolution 3'b010: 20 bit resolution 3'b011: 24 bit resolution 3'b100: 32 bit resolution 3'b101~111: Reserved
[9:7]	RO	3'b0	I2S_RX_WORDSIZE_2	3'b000: 12 bit resolution 3'b001: 16 bit resolution 3'b010: 20 bit resolution 3'b011: 24 bit resolution 3'b100: 32 bit resolution 3'b101~111: Reserved
[6]	RO	1'b0	Reserved	Reserved
[5:3]	RO	3'b0	I2S_RX_WORDSIZE_1	3'b000: 12 bit resolution 3'b001: 16 bit resolution 3'b010: 20 bit resolution 3'b011: 24 bit resolution 3'b100: 32 bit resolution 3'b101~111: Reserved
[2:0]	RO	3'b0	I2S_RX_WORDSIZE_0	3'b000: 12 bit resolution 3'b001: 16 bit resolution 3'b010: 20 bit resolution 3'b011: 24 bit resolution 3'b100: 32 bit resolution 3'b101~111: Reserved
0x1f4		I2S_COMP_PARAM_1		
[31:28]	RO	4'b0	Reserved	Reserved
[27:25]	RO	3'b0	I2S_TX_WORDSIZE_3	3'b000: 12 bit resolution 3'b001: 16 bit resolution 3'b010: 20 bit resolution 3'b011: 24 bit resolution 3'b100: 32 bit resolution 3'b101~111: Reserved
[24:22]	RO	3'b0	I2S_TX_WORDSIZE_2	3'b000: 12 bit resolution 3'b001: 16 bit resolution 3'b010: 20 bit resolution 3'b011: 24 bit resolution 3'b100: 32 bit resolution 3'b101~111: Reserved

[21:19]	RO	3'b0	I2S_TX_WORDSIZE_1	3'b000: 12 bit resolution 3'b001: 16 bit resolution 3'b010: 20 bit resolution 3'b011: 24 bit resolution 3'b100: 32 bit resolution 3'b101~111: Reserved
[18:16]	RO	3'b0	I2S_TX_WORDSIZE_0	3'b000: 12 bit resolution 3'b001: 16 bit resolution 3'b010: 20 bit resolution 3'b011: 24 bit resolution 3'b100: 32 bit resolution 3'b101~111: Reserved
[15:11]	RO	5'b0	Reserved	Reserved
[10:9]	RO	2'b0	I2S_TX_CHANNELS	2'b00: 1 channel 2'b01: 2 channels 2'b10: 3 channels 2'b11: 4 channels
[8:7]	RO	2'b0	I2S_RX_CHANNELS	2'b00: 1 channel 2'b01: 2 channels 2'b10: 3 channels 2'b11: 4 channels
[6]	RO	1'b0	I2S_RECEIVER_BLOCK	1'b0: FALSE 1'b1: TRUE
[5]	RO	1'b0	I2S_TRANSMITTER_BLOCK	1'b0: FALSE 1'b1: TRUE
[4]	RO	1'b0	I2S_MODE_EN	1'b0: FALSE 1'b1: TRUE
[3:2]	RO	2'b0	I2S_FIFO_DEPTH_GLOVAL	2'b00: 2 2'b01: 4 2'b10: 8 2'b11: 16
[1:0]	RO	2'b0	APB_DATA_WIDTH	2'b00: 8 2'b01: 16 2'b10: 32 2'b11: Reserved

0x1f8 I2S_COMP_VERSION

[31:28]	RO	32'b0	I2S_COMP_VERSION	Specific values for this register are described in the Releases Table in the AMBA 2 release notes
---------	----	-------	------------------	---------------------------------------------------------------------------------------------------

4.10 UART (UART)

The Universal Asynchronous Receiver/Transmitter offers fast, full-duplex, asynchronous serial communication with built-in flow control (CTS, RTS) support in HW up to 1Mbps baud. Parity checking and generation for the 9th data bit are supported.

The GPIOs used for each UART interface line can be chosen from any GPIO on the device and are independently configurable. This enables great flexibility in device pin out and enables efficient use of board space and signal routing.

UART registers are listed below:

Base address: 4000_4000

OFFSET	TYP E	RESET	NAME	DESCRIPTION
0x00			RBR(Receive Buffer Register)	LCR[7] bit = 0
[31:8]	RO	24'b0	Reserved	Reserved
[7:0]	RO	8'b0	Receive Buffer Register	LSR[0] bit = 1,The data in this register is valid
0x00			THR(Transmit Holding Register)	LCR[7] bit = 0
[31:8]	WO	24'b0	Reserved	Reserved
[7:0]	WO	8'b0	Transmit Holding Register	LSR[5] bit = 1,The data should only be written to the THR
0x00			DLL(Divisor Latch Low)	1.When UART_16550 == YES,Then LCR[7] bit = 1 2.When UART_16550 == NO,Then LCR[7] bit = 1,USR[0] = 0
[31:8]	RO	24'b0	Reserved	Reserved
[7:0]	RW	8'b0	Divisor Latch (low)	baud rate = (serial clock freq) / (16 * divisor)
0x04			DLH(Divisor Latch High)	1.When UART_16550 == YES,Then LCR[7] bit = 1 2.When UART_16550 == NO,Then LCR[7] bit = 1,USR[0] = 0
[31:8]	RO	24'b0	Reserved	Reserved
[7:0]	RW	8'b0	Divisor Latch (high)	baud rate = (serial clock freq) / (16 * divisor)
0x04			IER(Interrupt Enable Register)	LCR[7] bit = 0
[31:8]	RO	24'b0	Reserved	Reserved
[7]	RW	1'b0	PTIME	This is used to enable/disable the generation of THRE Interrupt 1'b0: disable 1'b1: enable
[6:4]	RO	3'b0	Reserved	Reserved
[3]	RW	1'b0	EDSSI	This is used to enable/disable the generation of Modem Status Interrupt 1'b0: disable 1'b1: enable
[2]	RW	1'b0	ELSI	This is used to enable/disable the generation of Receiver Line Status Interrupt 1'b0: disable 1'b1: enable
[1]	RW	1'b0	ETBEI	This is used to enable/disable the generation of Transmitter Holding Register Empty Interrupt 1'b0: disable 1'b1: enable

[0]	RW	1'b0	ERBFI	This is used to enable/disable the generation of Received Data Available Interrupt and the Character Timeout Interrupt (if in FIFO mode and FIFOs enabled) 1'b0: disable 1'b1: enable
0x08			IIR(Interrupt Identity Register)	
[31:8]	RO	24'b0	Reserved	Reserved
[7:6]	RO	2'b0	FIFOSE	This is used to indicate whether the FIFOs are enabled or disabled 2'b00: disable 2'b11: enable
[5:4]	RO	2'b0	Reserved	Reserved
[3:0]	RO	4'b0001	IID	This is used to indicates the highest priority pending interrupt which can be one of the following types 4'b0000: modem status 4'b0001: no interrupt pending 4'b0010: THR empty 4'b0100: received data available 4'b0110: receiver line status 4'b0111: busy detect 4'b1100: character timeout
0x08			FCR(FIFO Control Register)	FIFO_MODE != NONE
[31:8]	RO	24'b0	Reserved	Reserved
[7:6]	WO	2'b0	RT	This is used to select the trigger level in the receiver FIFO at which the Received Data Available Interrupt is generated,The following trigger levels are supported: 2'b00: 1 character in the FIFO 2'b01: FIFO ¼ full 2'b10: FIFO ½ full 2'b11: FIFO 2 less than full
[5:4]	WO	2'b0	TET	This is used to select the empty threshold level at which the THRE Interrupts are generated when the mode is active,The following trigger levels are supported: 2'b00: FIFO empty 2'b01: 2 characters in the FIFO 2'b10: FIFO ¼ full 2'b11: FIFO ½ full
[3]	WO	1'b0	DMAM	This determines the DMA signalling mode 1'b0: mode 0 1'b1: mode 1
[2]	WO	1'b0	XFIFOR	This resets the control portion of the transmit FIFO and treats the FIFO as empty

[1]	WO	1'b0	RFIFOR	This resets the control portion of the receive FIFO and treats the FIFO as empty
[0]	WO	1'b0	FIFOE	This enables/disables the transmit (XMIT) and receive (RCVR) FIFOs 1'b0: disable 1'b1: enable
0x0C LCR(Line Control Register)				
[31:8]	RO	24'b0	Reserved	Reserved
[7]	RW	1'b0	DLAB	USR[0]=0,the bit is writeable;This bit is used to enable reading and writing of the Divisor Latch register (DLL and DLH) to set the baud rate of the UART 1'b0: disable 1'b1: enable
[6]	RW	1'b0	Break	This is used to cause a break condition to be transmitted to the receiving device
[5]	RO	1'b0	Reserved	Reserved
[4]	RW	1'b0	EPS	USR[0]=0,the bit is writeable;This is used to select between even and odd parity,when parity is enabled (PEN set to one) 1'b0: an odd number of logic 1s is transmitted or checked 1'b1: an even number of logic 1s is transmitted or checked
[3]	RW	1'b0	PEN	USR[0]=0,the bit is writeable;enable and disable parity generation and detection in transmitted and received serial character respectively 1'b0: disable 1'b1: enable
[2]	RW	1'b0	STOP	USR[0]=0,the bit is writeable;select the number of stop bits per character that the peripheral transmits and receives 1'b0: 1 stop bit 1'b1: 1.5 stop bits when DLS (LCR[1:0]) is zero, else 2 stop bit
[1:0]	RW	2'b0	DLS	USR[0]=0,the bit is writeable;This is used to select the number of data bits per character that the peripheral transmits and receives. The number of bit that may be selected areas follows: 2'b00: 5 bits 2'b01: 6 bits 2'b10: 7 bits 2'b11: 8 bits
0x10 MCR(Modem Control Register)				

[31:7]	RO	25'b0	Reserved	Reserved
[6]	RW	1'b0	SIRE	SIR_MODE == Enabled,the bit is writeable;enable/disable the IrDA SIR Mode 1'b0: disable 1'b1: enable
[5]	RW	1'b0	AFCE	AFCE_MODE == Enabled,the bit is writeable;enable/disable the Auto Flow Control 1'b0: disable 1'b1: enable
[4]	RW	1'b0	LoopBack	This is used to put the UART into a diagnostic mode for test purposes This is used to directly control the user-designated Output2
[3]	RW	1'b0	OUT2	(out2_n) output 1'b0: de-asserted (logic 1) 1'b1: asserted (logic 0)
[2]	RW	1'b0	OUT1	This is used to directly control the user-designated Output1 (out1_n) output 1'b0: de-asserted (logic 1) 1'b1: asserted (logic 0)
[1]	RW	1'b0	RTS	Request to Send. This is used to directly control the Request to Send (rts_n) output 1'b0: de-asserted (logic 1) 1'b1: asserted (logic 0)
[0]	RW	1'b0	DTR	This is used to directly control the Data Terminal Ready (dtr_n) output 1'b0: de-asserted (logic 1) 1'b1: asserted (logic 0)
0x14			LSR(Line Status Register)	
[31:8]	RO	24'b0	Reserved	Reserved
[7]	RO	1'b0	RFE	FIFO_MODE != NONE and FCR[0] = 1,the bit is relevant;This is used to indicate if there is at least one parity error, framing error, or break indication in the FIFO 1'b0: no error 1'b1: error
[6]	RO	1'b1	TEMT	Transmitter Empty bit; FIFO_MODE != NONE and FCR[0] = 1,this bit is set whenever the Transmitter Shift Register and the FIFO are both empty
[5]	RO	1'b1	THRE	FIFO_MODE == NONE and FCR[0] = 0,this bit is set whenever the Transmitter Holding Register and the Transmitter Shift Register are both empty Transmit Holding Register Empty bit

[4]	RO	1'b0	BI	This is used to indicate the detection of a break sequence on the serial input data.
[3]	RO	1'b0	FE	This is used to indicate the occurrence of a framing error in the receiver 1'b0: no framing error 1'b1: framing error
[2]	RO	1'b0	PE	This is used to indicate the occurrence of a parity error in the receiver if the Parity Enable (PEN) bit (LCR[3]) is set 1'b0: no parity error 1'b1: parity error
[1]	RO	1'b0	OE	This is used to indicate the occurrence of an overrun error 1'b0: no overrun error 1'b1: overrun error
[0]	RO	1'b0	DR	This is used to indicate that the receiver contains at least one character in the RBR or the receiver FIFO 1'b0: no data ready 1'b1: data ready
0x18 MSR(Modem Status Register)				
[31:8]	RO	24'b0	Reserved	Reserved
[7]	RO	1'b0	DCD	This is used to indicate the current state of the modem control line dcd_n 1'b0: de-asserted (logic 1) 1'b1: asserted (logic 0)
[6]	RO	1'b0	RI	This is used to indicate the current state of the modem control line ri_n 1'b0: de-asserted (logic 1) 1'b1: asserted (logic 0)
[5]	RO	1'b0	DSR	This is used to indicate the current state of the modem control line dsr_n 1'b0: de-asserted (logic 1) 1'b1: asserted (logic 0)
[4]	RO	1'b0	CTS	This is used to indicate the current state of the modem control line cts_n 1'b0: de-asserted (logic 1) 1'b1: asserted (logic 0)
[3]	RO	1'b0	DDCD	This is used to indicate that the modem control line dcd_n has changed since the last time the MSR was read 1'b0: no change on dcd_n since last read of MSR 1'b1: change on dcd_n since last read of MSR
[2]	RO	1'b0	TERI	This is used to indicate that a change on the input ri_n has occurred since the last time the MSR was read

				1'b0: no change on ri_n since last read of MSR 1'b1: change on ri_n since last read of MSR
[1]	RO	1'b0	DDSR	This is used to indicate that the modem control line dsr_n has changed since the last time the MSR was read 1'b0: no change on dsr_n since last read of MSR 1'b1: change on dsr_n since last read of MSR
[0]	RO	1'b0	DCTS	This is used to indicate that the modem control line cts_n has changed since the last time the MSR was read 1'b0: no change on ctsdsr_n since last read of MSR 1'b1: change on ctsdsr_n since last read of MSR
0x1C				
SCR(Scratchpad Register)				
[31:8]	RO	24'b0	Reserved	Reserved
[7:0]	RW	8'b0	Scratchpad Register	This register is for programmers to use as a temporary storage space
0x20				
LPDLL(Low Power Divisor Latch Low Register)				
[31:8]	RO	24'b0	Reserved	Reserved
[7:0]	RW	8'b0	LPDLL	This register makes up the lower 8-bits of a 16-bit, this register that contains the baud rate divisor for the UART
0x24				
LPDLH(Low Power Divisor Latch High Register)				
[31:8]	RO	24'b0	Reserved	Reserved
[7:0]	RW	8'b0	LPDLH	This register makes up the upper 8-bits of a 16-bit, this register that contains the baud rate divisor for the UART
0x30~0x6c				
SRBR(Shadow Receive Buffer Register)				
[31:8]	RO	24'b0	Reserved	Reserved
[7:0]	RO	8'b0	Shadow Receive Buffer Register	SHADOW == YES and LCR[7] bit = 0 This is a shadow register for the RBR and has been allocated sixteen 32-bit locations so as to accommodate burst accesses from the master
0x30~0x6c				
STHR(Shadow Transmit Holding Register)				
[31:8]	RO	24'b0	Reserved	Reserved

[7:0]	WO	8'b0	Shadow Transmit Holding Register	This is a shadow register for the THR and has been allocated sixteen 32-bit locations so as to accommodate burst accesses from the master
0x70		FAR(FIFO Access Register)		
[31:1]	RO	31'b0	Reserved	Reserved
[0]	RW	1'b0	FIFO Access Register	Writes have no effect when FIFO_ACCESS == No, always readable, This register is use to enable a FIFO access mode for testing 1'b0: disable 1'b1: enable
0x74		TFR(Transmit FIFO Read)		FIFO_ACCESS == YES
[31:8]	RO	24'b0	Reserved	Reserved
[7:0]	RO	8'b0	Transmit FIFO Read	FAR[0] = 1, the bit is valid; Reading this register gives the data at the top of the transmit FIFO or the data in the THR
0x78		RFW(Receive FIFO Write)		FIFO_ACCESS == YES
[31:10]	RO	22'b0	Reserved	Reserved
[9]	WO	1'b0	RFFE	FAR[0] = 1, the bit is valid; This bit is used to write framing error detection information to the receive FIFO or the RBR
[8]	WO	1'b0	RFPE	FAR[0] = 1, the bit is valid; This bit is used to write parity error detection information to the receive FIFO or the RBR
[7:0]	WO	8'b0	RFWD	FAR[0] = 1, the bit is valid; This bit of the data that is written to the RFWD is pushed into the receive FIFO or the RBR
0x7C		USR(UART Status Register)		
[31:5]	RO	27'b0	Reserved	Reserved
[4]	RO	1'b0	RFF	FIFO_STAT == YES, the bit is valid; This is used to indicate that the receive FIFO is completely full 1'b0: not full 1'b1: full
[3]	RO	1'b0	RFNE	FIFO_STAT == YES, the bit is valid; This is used to indicate that the receive FIFO contains one or more entries 1'b0: empty 1'b1: not empty
[2]	RO	1'b1	TFE	FIFO_STAT == YES, the bit is valid; This is used to indicate that the transmit FIFO is completely empty 1'b0: not empty 1'b1: empty

[1]	RO	1'b1	TFNF	FIFO_STAT == YES,the bit is valid;This is used to indicate that the transmit FIFO in not full 1'b0: full 1'b1: not full
[0]	RO	1'b0	BUSY	This indicates that a serial transfer is in progress, when cleared indicates that the DW_apb_uart is idle or inactive 1'b0: idle or inactive 1'b1: busy (actively transferring data)
0x80			TFL(Transmit FIFO Level)	FIFO_STAT == YES;FIFO_ADDR_WIDTH=4
[31:5]	RO	27'b0	Reserved	Reserved
[4:0]	RO	5'b0	Transmit FIFO Level	This indicates the number of data entries in the transmit FIFO
0x84			RFL(Receive FIFO Level)	FIFO_STAT == YES;FIFO_ADDR_WIDTH=4
[31:5]	RO	27'b0	Reserved	Reserved
[4:0]	RO	5'b0	Receive FIFO Level	This indicates the number of data entries in the receive FIFO
0x88			SRR(Software Reset Register)	SHADOW == YES
[31:3]	RO	29'b0	Reserved	Reserved
[2]	WO	1'b0	XFR	FIFO_MODE == None,the written have no effect;XMIT FIFO Reset. This is a shadow register for the XMIT FIFO Reset bit(FCR[2])
[1]	WO	1'b0	RFR	FIFO_MODE == None,the written have no effect;RCVR FIFO Reset. This is a shadow register for the RCVR FIFO Reset bit(FCR[1])
[0]	WO	1'b0	UR	This asynchronously resets the DW_apb_uart and synchronously removes the reset assertion
0x8C			SRTS(Shadow Request to Send)	SHADOW == YES
[31:1]	RO	31'b0	Reserved	Reserved
[0]	RW	1'b0	Shadow Request to Send	This is a shadow register for the RTS bit(MCR[1])
0x90			SBCR(Shadow Break Control Register)	SHADOW == YES
[31:1]	RO	31'b0	Reserved	Reserved
[0]	RW	1'b0	Shadow Break Control Register	This is a shadow register for the Break bit(LCR[6])
0x94			SDMAM(Shadow DMA Mode)	FIFO_MODE != None and SHADOW == YES
[31:1]	RO	31'b0	Reserved	Reserved
[0]	RW	1'b0	Shadow DMA Mode	This is a shadow register for the DMA mode bit(FCR[3]) 1'b0: mode 0

1'b1: mode 1

0x98				SFE(Shadow FIFO Enable)	FIFO_MODE != None and SHADOW == YES
[31:1]	RO	31'b0	Reserved	Reserved	
[0]	RW	1'b0	Shadow FIFO Enable		This is a shadow register for the FIFO enable bit(FCR[0]) 1'b0: disable 1'b1: enable
0x9C				SRT(Shadow RCVR Trigger)	FIFO_MODE != None and SHADOW == YES
[31:2]	RO	30'b0	Reserved	Reserved	
[1:0]	RW	2'b0	Shadow RCVR Trigger		This is a shadow register for the RCVR trigger bits(FCR[7:6]) 2'b00: 1 character in the FIFO 2'b01: FIFO ¼ full 2'b10: FIFO ½ full 2'b11: FIFO 2 less than full
0xA0				STET(Shadow TX Empty Trigger)	FIFO_MODE != None and THRE_MODE_USER == Enabled and SHADOW == YES
[31:2]	RO	30'b0	Reserved	Reserved	
[1:0]	RW	2'b0	Shadow TX Empty Trigger		THRE_MODE_USER == Disabled,the written have no effect;This is a shadow register for the TX empty trigger bits (FCR[5:4]) 2'b00: FIFO empty 2'b01: 2 characters in the FIFO 2'b10: FIFO ¼ full 2'b11: FIFO ½ full
0xA4				HTX(Halt TX)	
[31:1]	RO	31'b0	Reserved	Reserved	
[0]	RW	1'b0	Halt TX		FIFO_MODE == None,the written have no effect;This register is use to halt transmissions for testing 1'b0: disable 1'b1: enable
0xA8				DMASA(DMA Software Acknowledge)	
[31:1]	RO	31'b0	Reserved	Reserved	
[0]	WO	1'b0	DMA Software Acknowledge		DMA_EXTRA == No,the written have no effect;This register is use to perform a DMA software acknowledge if a transfer needs to be terminated due to an error condition
0xF4				CPR(Component Parameter Register)	UART_ADD_ENCODED_PARAMS == YES
[31:24]	RO	8'b0	Reserved	Reserved	

[23:16]	RO	8'b0	FIFO_MODE	8'b0x00: 0 8'b0x01: 16 8'b0x02: 32 8'b0x80: 2048 8'b0x81- 0xff: reserved
[15:14]	RO	2'b0	Reserved	Reserved
[13]	RO	1'b0	DMA_EXTRA	1'b0: FALSE 1'b1: TRUE
[12]	RO	1'b0	UART_ADD_ENCODED_PARAMS	1'b0: FALSE 1'b1: TRUE
[11]	RO	1'b0	SHADOW	1'b0: FALSE 1'b1: TRUE
[10]	RO	1'b0	FIFO_STAT	1'b0: FALSE 1'b1: TRUE
[9]	RO	1'b0	FIFO_ACCESS	1'b0: FALSE 1'b1: TRUE
[8]	RO	1'b0	ADDITIONAL_FEAT	1'b0: FALSE 1'b1: TRUE
[7]	RO	1'b0	SIR_LP_MODE	1'b0: FALSE 1'b1: TRUE
[6]	RO	1'b0	SIR_MODE	1'b0: FALSE 1'b1: TRUE
[5]	RO	1'b0	THRE_MODE	1'b0: FALSE 1'b1: TRUE
[4]	RO	1'b0	AFCE_MODE	1'b0: FALSE 1'b1: TRUE
[3:2]	RO	2'b0	Reserved	Reserved
[1:0]	RO	2'b0	APB_DATA_WIDTH	2'b00: 8 bits 2'b01: 16 bits 2'b10: 32 bits 2'b11: reserved
0xF8			UCV(UART Component Version)	ADDITIONAL_FEATURES == YES
[31:0]	RO	32'b0	UART Component Version	ASCII value for each number in the version, followed by *. For example 32_30_31_2A represents the version 2.01*
0xFC			CTR(Component Type Register)	ADDITIONAL_FEATURES == YES
[31:0]	RO	32'b0x44570110	Peripheral ID	This register contains the peripherals identification code

4.11 Pulse Width Modulation (PWM)

CMT4501 supports 6 channels of Pulse Width Modulation (PWM) outputs. PWM outputs generate waveforms with variable duty cycle or pulse width programmed by registers. And each of the 6 PWM outputs can be individually programmed. Their duty cycles are controlled by programming individual counters associated with each channel.

The master clock is 16MHz. For each PWM outputs, first there is a prescaler (pre-divider) with division

ratio of 2 to 128 (only 2^N division ratios are supported), followed by another 16bit counter with programmable max count, denoted as top_count. When the 16bit counter counts from 0 to top_count, it resets back to 0. So the frequency of the PWM is given by:

$$\text{Freq_PWM} = 16\text{MHz} / (\text{N_prescaler} * \text{N_top_count});$$

A threshold counter number can be programmed, when the 16bit counter reaches the threshold, PWM output toggles. So the duty cycle is:

$$\text{Duty_cycle_PWM} = \text{N_threshold} / \text{N_top_count};$$

The polarity of the PWM can also be programmed, which indicates output 1 or 0 when counter is below/above the threshold. A PWM waveform vs counter values are illustrated in the following Figure 13, where the polarity is positive. Also in this case the counter ramps up and then resets, we call it “up mode”.

There is also a “up and down mode”, where the counter ramps up to count_top and then ramps down, instead of reset.

As discussed above, the key register bits for one PWM channel are: 16bit top_count, 16bit threshold count, 3bit prescaler count, PWM polarity, PWM mode (up or up/down), PWM enable, and PWM load enable (load new settings). All 6 PWM channels can be individually programmed by registers with addresses from 0x4000_E004 to 0x4000_E044. In addition, one should enable registers 0x4000_E000<0><4> to allow all PWM channels can be programmed. For details please refer to documents of CMT4501 register tables.

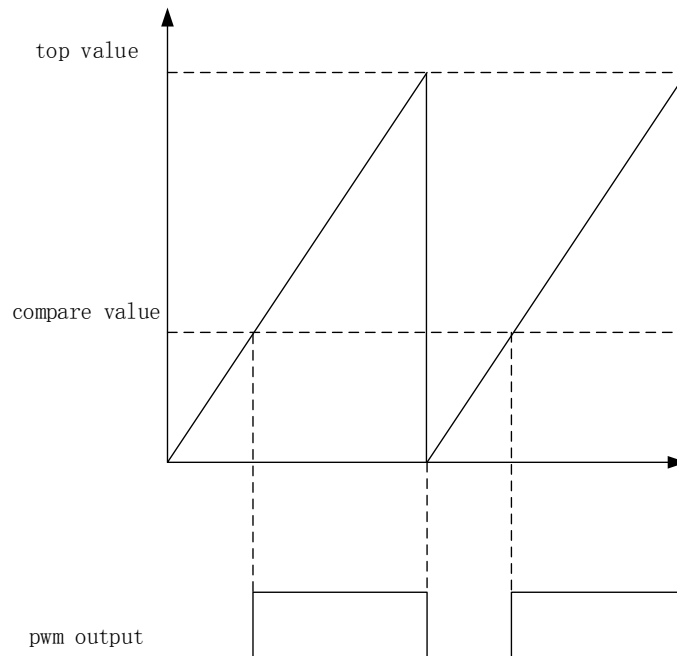

Figure13: PWM operation

PWM related registers are listed below:

Base address: 4000_E000

OFFSET	TYPE	RESET	NAME	DESCRIPTION
0x00			PWMEN	pwm enable
[31 : 18]	RO	14'b0	reserved	Reserved
[17]	RW	1'b0	pwm_load_45	load parameter of PWM channel 4, 5. need to be conjunction with setting bit16 of PWMxCTL0 registers. 1'b0: no load 1'b1: load
[16]	RW	1'b0	pwm_en_45	enable of PWM channel 4, 5. need to be conjunction with setting bit0 of PWMxCTL0 registers. 1'b0: disable 1'b1: enable
[15]	RW	1'b0	pwm_load_23	load parameter of PWM channel 2, 3. need to be conjunction with setting bit16 of PWMxCTL0 registers. 1'b0: no load 1'b1: load
[14]	RW	1'b0	pwm_en_23	enable of PWM channel 2, 3. need to be conjunction with setting bit0 of PWMxCTL0 registers. 1'b0: disable 1'b1: enable
[13]	RW	1'b0	pwm_load_01	load parameter of PWM channel 0, 1. need to be conjunction with setting bit16 of PWMxCTL0 registers. 1'b0: no load 1'b1: load
[12]	RW	1'b0	pwm_en_01	enable of PWM channel 0, 1. need to be conjunction with setting bit0 of PWMxCTL0 registers. 1'b0: disable 1'b1: enable
[11]	RW	1'b0	pwm_load_345	load parameter of PWM channel 3, 4, 5. need to be conjunction with setting bit16 of PWMxCTL0 registers. 1'b0: no load 1'b1: load
[10]	RW	1'b0	pwm_en_345	enable of PWM channel 3, 4, 5. need to be conjunction with setting bit0 of PWMxCTL0 registers. 1'b0: disable 1'b1: enable
[9]	RW	1'b0	pwm_load_012	load parameter of PWM channel 0, 1, 2. need to be conjunction with setting bit16 of PWMxCTL0 registers. 1'b0: no load 1'b1: load
[8]	RW	1'b0	pwm_en_012	enable of PWM channel 0, 1, 2. need to be conjunction with setting bit0 of PWMxCTL0 registers. 1'b0: disable 1'b1: enable
[7 : 5]	RO	3'b0	reserved	Reserved

[4]	RW	1'b0	pwm_load_all	load parameter of all six PWM channels. need to be conjunction with setting bit16 of PWMxCTL0 registers. 1'b0: no load 1'b1: load
[3 : 1]	RO	3'b0	reserved	Reserved
[0]	RW	1'b0	pwm_en_all	enable of all six PWM channels. need to be conjunction with setting bit0 of PWMxCTL0 registers. 1'b0: disable 1'b1: enable

0x04	PWM0CTL0		pwm channel 0 contrl reigister	
------	----------	--	--------------------------------	--

[31]	RW	1'b0	pwm0_load_instant	instant load parameter of PWM channel 0. 1'b0: no load 1'b1: instant load
[30 : 17]	RO	14'b0	reserved	Reserved
[16]	RW	1'b0	pwm0_load	load parameter of PWM channel 0. 1'b0: no load 1'b1: load
[15]	RO	1'b0	reserved	Reserved
[14 : 12]	RW	3'b0	pwm0_clk_div	clock prescaler of PWM channel 0. 3'b000: pwm_clk is divided by 1 for count clock 3'b001: pwm_clk is divided by 2 for count clock 3'b010: pwm_clk is divided by 4 for count clock 3'b011: pwm_clk is divided by 8 for count clock 3'b100: pwm_clk is divided by 16 for count clock 3'b101: pwm_clk is divided by 32 for count clock 3'b110: pwm_clk is divided by 64 for count clock 3'b111: pwm_clk is divided by 128 for count clock
[11 : 9]	RO	3'b0	reserved	Reserved
[8]	RW	1'b0	pwm0_cnt_mode	count mode of PWM channel 0. 1'b0: up mode 1'b1: up and down mode
[7 : 5]	RO	3'b0	reserved	Reserved
[4]	RW	1'b0	pwm0_polarity	output polarity setting of PWM channel 0. 1'b0: rising edge. Second edge within the PWM period is rising 1'b1: falling edge. Second edge within the PWM period is falling
[3 : 1]	RO	3'b0	reserved	Reserved
[0]	RW	1'b0	pwm0_en	enable of PWM channel 0. 1'b0: disable 1'b1: enable

0x08	PWM0CTL1		pwm channel 0 conter value setting	
------	----------	--	------------------------------------	--

[31 : 16]	RW	16'b0	pwm0_cmp_val	the compare value of PWM channel 0
-----------	----	-------	--------------	------------------------------------

[15 : 0] RW 16'b0 pwm0_cnt_top the counter top value of PWM channel 0

0x10 PWM1CTL0 pwm channel 1 contrl reigister

[31] RW 1'b0 pwm1_load_instant instant load parameter of PWM channel 1.
1'b0: no load
1'b1: instant load

[30 : 17] RO 14'b0 reserved Reserved

[16] RW 1'b0 pwm1_load load parameter of PWM channel 1.
1'b0: no load
1'b1: load

[15] RO 1'b0 reserved Reserved

[14 : 12] RW 3'b0 pwm1_clk_div clock prescaler of PWM channel 1.
3'b000: pwm_clk is divided by 1 for count clock
3'b001: pwm_clk is divided by 2 for count clock
3'b010: pwm_clk is divided by 4 for count clock
3'b011: pwm_clk is divided by 8 for count clock
3'b100: pwm_clk is divided by 16 for count clock
3'b101: pwm_clk is divided by 32 for count clock
3'b110: pwm_clk is divided by 64 for count clock
3'b111: pwm_clk is divided by 128 for count clock

[11 : 9] RO 3'b0 reserved Reserved

[8] RW 1'b0 pwm1_cnt_mode count mode of PWM channel 1.
1'b0: up mode
1'b1: up and down mode

[7 : 5] RO 3'b0 reserved Reserved

[4] RW 1'b0 pwm1_polarity output polarity setting of PWM channel 1.
1'b0: rising edge. Second edge within the PWM period is rising
1'b1: falling edge. Second edge within the PWM period is falling

[3 : 1] RO 3'b0 reserved Reserved

[0] RW 1'b0 pwm1_en enable of PWM channel 1.
1'b0: disable
1'b1: enable

0x14 PWM1CTL1 pwm channel 1 conter value setting

[31 : 16] RW 16'b0 pwm1_cmp_val the compare value of PWM channel 1

[15 : 0] RW 16'b0 pwm1_cnt_top the counter top value of PWM channel 1

0x1C PWM2CTL0 pwm channel 2 contrl reigister

[31] RW 1'b0 pwm2_load_instant instant load parameter of PWM channel 2.
1'b0: no load
1'b1: instant load

[30 : 17]	RO	14'b0	reserved	Reserved
[16]	RW	1'b0	pwm2_load	load parameter of PWM channel 2. 1'b0: no load 1'b1: load
[15]	RO	1'b0	reserved	Reserved
[14 : 12]	RW	3'b0	pwm2_clk_div	clock prescaler of PWM channel 2. 3'b000: pwm_clk is divided by 1 for count clock 3'b001: pwm_clk is divided by 2 for count clock 3'b010: pwm_clk is divided by 4 for count clock 3'b011: pwm_clk is divided by 8 for count clock 3'b100: pwm_clk is divided by 16 for count clock 3'b101: pwm_clk is divided by 32 for count clock 3'b110: pwm_clk is divided by 64 for count clock 3'b111: pwm_clk is divided by 128 for count clock
[11 : 9]	RO	3'b0	reserved	Reserved
[8]	RW	1'b0	pwm2_cnt_mode	count mode of PWM channel 2. 1'b0: up mode 1'b1: up and down mode
[7 : 5]	RO	3'b0	reserved	Reserved
[4]	RW	1'b0	pwm2_polarity	output polarity setting of PWM channel 2. 1'b0: rising edge. Second edge within the PWM period is rising 1'b1: falling edge. Second edge within the PWM period is falling
[3 : 1]	RO	3'b0	reserved	Reserved
[0]	RW	1'b0	pwm2_en	enable of PWM channel 2. 1'b0: disable 1'b1: enable

0x20			PWM2CTL1	pwm channel 2 conter value setting
[31 : 16]	RW	16'b0	pwm2_cmp_val	the compare value of PWM channel 2
[15 : 0]	RW	16'b0	pwm2_cnt_top	the counter top value of PWM channel 2

0x28			PWM3CTL0	pwm channel 3 contrl reigister
[31]	RW	1'b0	pwm3_load_instant	instant load parameter of PWM channel 3. 1'b0: no load 1'b1: instant load
[30 : 17]	RO	14'b0	reserved	Reserved
[16]	RW	1'b0	pwm3_load	load parameter of PWM channel 3. 1'b0: no load 1'b1: load
[15]	RO	1'b0	reserved	Reserved

[14 : 12]	RW	3'b0	pwm3_clk_div	clock prescaler of PWM channel 3. 3'b000: pwm_clk is divided by 1 for count clock 3'b001: pwm_clk is divided by 2 for count clock 3'b010: pwm_clk is divided by 4 for count clock 3'b011: pwm_clk is divided by 8 for count clock 3'b100: pwm_clk is divided by 16 for count clock 3'b101: pwm_clk is divided by 32 for count clock 3'b110: pwm_clk is divided by 64 for count clock 3'b111: pwm_clk is divided by 128 for count clock
[11 : 9]	RO	3'b0	reserved	Reserved
[8]	RW	1'b0	pwm3_cnt_mode	count mode of PWM channel 3. 1'b0: up mode 1'b1: up and down mode
[7 : 5]	RO	3'b0	reserved	Reserved
[4]	RW	1'b0	pwm3_polarity	output polarity setting of PWM channel 3. 1'b0: rising edge. Second edge within the PWM period is rising 1'b1: falling edge. Second edge within the PWM period is falling
[3 : 1]	RO	3'b0	reserved	Reserved
[0]	RW	1'b0	pwm3_en	enable of PWM channel 3. 1'b0: disable 1'b1: enable

0x2C			PWM3CTL1	pwm channel 0 conter value setting
-------------	--	--	-----------------	-------------------------------------------

[31 : 16]	RW	16'b0	pwm3_cmp_val	the compare value of PWM channel 3
[15 : 0]	RW	16'b0	pwm3_cnt_top	the counter top value of PWM channel 3

0x34			PWM4CTL0	pwm channel 4 contrl reigister
-------------	--	--	-----------------	---------------------------------------

[31]	RW	1'b0	pwm4_load_instant	instant load parameter of PWM channel 4. 1'b0: no load 1'b1: instant load
[30 : 17]	RO	14'b0	reserved	Reserved
[16]	RW	1'b0	pwm4_load	load parameter of PWM channel 4. 1'b0: no load 1'b1: load
[15]	RO	1'b0	reserved	Reserved

[14 : 12]	RW	3'b0	pwm4_clk_div	clock prescaler of PWM channel 4. 3'b000: pwm_clk is divided by 1 for count clock 3'b001: pwm_clk is divided by 2 for count clock 3'b010: pwm_clk is divided by 4 for count clock 3'b011: pwm_clk is divided by 8 for count clock 3'b100: pwm_clk is divided by 16 for count clock 3'b101: pwm_clk is divided by 32 for count clock 3'b110: pwm_clk is divided by 64 for count clock 3'b111: pwm_clk is divided by 128 for count clock
[11 : 9]	RO	3'b0	reserved	Reserved
[8]	RW	1'b0	pwm4_cnt_mode	count mode of PWM channel 4. 1'b0: up mode 1'b1: up and down mode
[7 : 5]	RO	3'b0	reserved	Reserved
[4]	RW	1'b0	pwm4_polarity	output polarity setting of PWM channel 4. 1'b0: rising edge. Second edge within the PWM period is rising 1'b1: falling edge. Second edge within the PWM period is falling
[3 : 1]	RO	3'b0	reserved	Reserved
[0]	RW	1'b0	pwm4_en	enable of PWM channel 4. 1'b0: disable 1'b1: enable

0x38			PWM4CTL1	pwm channel 4 conter value setting
-------------	--	--	-----------------	-------------------------------------------

[31 : 16]	RW	16'b0	pwm4_cmp_val	the compare value of PWM channel 4
[15 : 0]	RW	16'b0	pwm4_cnt_top	the counter top value of PWM channel 4

0x40			PWM5CTL0	pwm channel 5 contrl reigister
-------------	--	--	-----------------	---------------------------------------

[31]	RW	1'b0	pwm5_load_instant	instant load parameter of PWM channel 5. 1'b0: no load 1'b1: instant load
[30 : 17]	RO	14'b0	reserved	Reserved
[16]	RW	1'b0	pwm5_load	load parameter of PWM channel 5. 1'b0: no load 1'b1: load
[15]	RO	1'b0	reserved	Reserved

[14 : 12]	RW	3'b0	pwm5_clk_div	clock prescaler of PWM channel 5. 3'b000: pwm_clk is divided by 1 for count clock 3'b001: pwm_clk is divided by 2 for count clock 3'b010: pwm_clk is divided by 4 for count clock 3'b011: pwm_clk is divided by 8 for count clock 3'b100: pwm_clk is divided by 16 for count clock 3'b101: pwm_clk is divided by 32 for count clock 3'b110: pwm_clk is divided by 64 for count clock 3'b111: pwm_clk is divided by 128 for count clock
[11 : 9]	RO	3'b0	reserved	Reserved
[8]	RW	1'b0	pwm5_cnt_mode	count mode of PWM channel 5. 1'b0: up mode 1'b1: up and down mode
[7 : 5]	RO	3'b0	reserved	Reserved
[4]	RW	1'b0	pwm5_polarity	output polarity setting of PWM channel 5. 1'b0: rising edge. Second edge within the PWM period is rising 1'b1: falling edge. Second edge within the PWM period is falling
[3 : 1]	RO	3'b0	reserved	Reserved
[0]	RW	1'b0	pwm5_en	enable of PWM channel 5. 1'b0: disable 1'b1: enable

0x44	PWM5CTL1		pwm channel 5 conter value setting	
[31 : 16]	RW	16'b0	pwm5_cmp_val	the compare value of PWM channel 5
[15 : 0]	RW	16'b0	pwm5_cnt_top	the counter top value of PWM channel 5

4.12 Quadrature Decoder (QDEC)

The quadrature decoder provides buffered decoding of quadrature-encoded sensor signals with input debounce filters. It is suitable for mechanical and optical sensors. The sample period and accumulation are configurable to match application requirements. The quadrature decoder has three-axis capability and index channel support. It can be programmed as 4x/2x/1x count mode.

Quadrature decoder related registers are listed below:

Base address: 4000_B000

OFFSET	TYPE	RESET	NAME	DESCRIPTION
0x00				
[31:9]	—	23'b0	reserved	
[8]	RW	1'b0	chnz_en	enable channel z
[7:5]	—	3'b0	reserved	
[4]	RW	1'b0	chny_en	enable channel y
[3:1]	—	3'b0	reserved	
[0]	RW	1'b0	chnx_en	enable channel x
0x04			int_enable	

[31:30]	—	2'b0	reserved	
[29]	RW	1'b0	int_quaz_02f_en	enable interupt, counter addition overflow (from 0 to F)
[28]	RW	1'b0	int_quaz_f20_en	enable interupt, counter subtraction overflow (from F to 0)
[27]	RW	1'b0	int_quay_02f_en	
[26]	RW	1'b0	int_quay_f20_en	
[25]	RW	1'b0	int_quax_02f_en	
[24]	RW	1'b0	int_quax_f20_en	
[23]	—	1'b0	reserved	
[22]	RW	1'b0	incz_int_mode	index counter interupt mode 0 index changes, 1 index equals hit
[21]	—	1'b0	reserved	
[20]	RW	1'b0	int_incz_en	enable index counter interupt
[19]	—	1'b0	reserved	
[18]	RW	1'b0	quaz_int_mode	quadrature counter interupt mode 0 index changes, 1 index equals hit
[17]	—	1'b0	reserved	
[16]	RW	1'b0	int_quaz_en	enable quadrature counter interupt
[15]	—	1'b0	reserved	
[14]	RW	1'b0	incy_int_mode	
[13]	—	1'b0	reserved	
[12]	RW	1'b0	int_incy_en	
[11]	—	1'b0	reserved	
[10]	RW	1'b0	quay_int_mode	
[9]	—	1'b0	reserved	
[8]	RW	1'b0	int_quay_en	
[7]	—	1'b0	reserved	
[6]	RW	1'b0	incx_int_mode	
[5]	—	1'b0	reserved	
[4]	RW	1'b0	int_incx_mode	
[3]	—	1'b0	reserved	
[2]	RW	1'b0	quax_int_mode	
[1]	—	1'b0	reserved	
[0]	RW	1'b0	int_quax_en	

0x08		int_clear		
[31:30]	—	2'b0	reserved	
[29]	WC	1'b0	quaz_02f_clr	clear 0 to F interupt
[28]	WC	1'b0	quaz_f20_clr	clear F to 0 interupt
[27]	WC	1'b0	quay_02f_clr	
[26]	WC	1'b0	quay_f20_clr	
[25]	WC	1'b0	quax_02f_clr	
[24]	WC	1'b0	quax_f20_clr	
[23:21]	—	3'b0	reserved	
[20]	WC	1'b0	incz_clr	clear index counter interupt

[19:17]	—	3'b0	reserved	
[16]	WC	1'b0	quaz_clr	clear quadrature counter interupt
[15:13]	—	3'b0	reserved	
[12]	WC	1'b0	incy_clr	
[11:9]	—	3'b0	reserved	
[8]	WC	1'b0	quay_clr	
[7:5]	—	3'b0	reserved	
[4]	WC	1'b0	incx_clr	
[3:1]	—	3'b0	reserved	
[0]	WC	1'b0	quax_clr	

0x0C			int_status	
[31:30]	—	2'b0	reserved	
[29]	RO	1'b0	int_quaz_02f	0 to F interupt status
[28]	RO	1'b0	int_quaz_f20	F to 0 interupt status
[27]	RO	1'b0	int_quay_02f	
[26]	RO	1'b0	int_quay_f20	
[25]	RO	1'b0	int_quax_02f	
[24]	RO	1'b0	int_quax_f20	
[23:21]	—	3'b0	reserved	
[20]	RO	1'b0	int_inc_z	index counter interupt status
[19:17]	—	3'b0	reserved	
[16]	RO	1'b0	int_qua_z	quadrature counter interupt status
[15:13]	—	3'b0	reserved	
[12]	RO	1'b0	int_inc_y	
[11:9]	—	3'b0	reserved	
[8]	RO	1'b0	int_qua_y	
[7:5]	—	3'b0	reserved	
[4]	RO	1'b0	int_inc_x	
[3:1]	—	3'b0	reserved	
[0]	RO	1'b0	int_qua_x	

0x10				
[31:18]	—	14'b0	reserved	
[17:16]	RW	2'b0	incx_mode	index counter mode 00 high level 01 positive edge 10 negtive edge 11 pos and neg edge
[15:2]	—	14'b0	reserved	
[1:0]	RW	2'b0	quax_mode	quadrature counter mode 01 mode 1x , 10 mode 2x, 11 mode 3x

0x14				
[31:0]	RW	32'b0	quax_hit	to compare with qua_cnt, trigger interupt

0x18				
[31:0]	RW	32'b0	incx_hit	to compare with inc_cnt, trigger interupt

0x1C				
[31:0]	RO	32'b0	quax_cnt	quadrature counter
0x20				
[31:0]	RO	32'b0	incx_cnt	index counter
0x24				
[31:18]	—	14'b0	reserved	
[17:16]	RW	2'b0	incy_mode	
[15:2]	—	14'b0	reserved	
[1:0]	RW	2'b0	quay_mode	
0x28				
[31:0]	RW	32'b0	quay_hit	
0x2C				
[31:0]	RW	32'b0	incy_hit	
0x30				
[31:0]	RO	32'b0	quay_cnt	
0x34				
[31:0]	RO	32'b0	incy_cnt	
0x38				
[31:18]	—	14'b0	reserved	
[17:16]	RW	2'b0	incz_mode	
[15:2]	—	14'b0	reserved	
[1:0]	RW	2'b0	quaz_mode	
0x3C				
[31:0]	RW	32'b0	quaz_hit	
0x40				
[31:0]	RW	32'b0	incz_hit	
0x44				
[31:0]	RO	32'b0	quaz_cnt	
0x48				
[31:0]	RO	32'b0	incz_cnt	
0x3FC				
[31:0]	RW	32'b0	dummy	

4.13 Key Scan (KSCAN)

Keyscan supports key matrix with upto 16 rows by 18 columns. Each individual rows or columns can be enabled or disabled through register settings. GPIO pins can be configured to be used for key scan. A few key scan Parameters can be set through registers, including polarity (low or high indicating key pressed); support multi-key-press or only single-key-press; de-bounce time (the time duration a key press is deemed valid) from 0 to 128mS with 255us step.

A valid key press can trigger an interrupt when keyscan interrupt is enabled. After a keyscan interrupt is serviced, writing 1 to the interrupt state register bit can clear the state bit.

The keyscan has a manual mode and an auto mode. For manual mode, when a keyscan interrupt is received, it is up to the MCU/software to scan the keyscan output pins and check the input pins, to determine which keys have been pressed. Manual mode is relatively slow and need CPU to process. On the contrary, in automode keyscan will automatically scan the output/input pins, and store the row/column info corresponding to the key pressed into read only registers, then trigger an interrupt for software to retrieve key press information.

Key scan related registers are listed below.

Base address: 4002_4000

OFFSET	TYPE	RESET	NAME	DESCRIPTION
0xC0				
[31:24]	RW	8'h00	mkdi	key scan debounce interval, 0-255, unit: 512uS
[23]	RW	1'b0	mk_pol	key matrix polarity, 0: active scan high, active sense high; 1: active scan low, active sense low;
[22]	RO	1'b0	reserved	no use/as
[21]	RW	1'b0	asact	auto scan on activity: 0, no auto scan, 1, auto scan on activity
[20]	RW	1'b0	imkp	ignore multi key press
[19:2]	RW	18'h0	ms	matrix scan outputs enable: 1: enable, 0: disable
[1]	RW	1'b0	ks_ie	key scan interrupt enable
[0]	RW	1'b0	ks_en	key scan enable
0xC4				
[31:18]	RO	14'b0	reserved	
[17]	WC	1'b0	mkp	key pressed indicator, 0: no key press, 1: key pressed, write 1 to clear
[16:1]	RO	16'h0FFF	mr	key scan inputs states
[0]	WC	1'b0	mi	interrupt state, write 1 to clear interrupt, 0: no interrupt, 1: interrupt issued,
0xC8				
[31:13]	RO	19'b0	reserved	
[12]	RO	1'b0	so	scan on: 1: auto scan is on going, 0: scan off
[11:10]	RO	2'b0	mukp	multi key pressed, 00, no key press, 01: 1 key press, 10, more than 1 key pressed
[9:5]	RO	5'h1F	rp	row of key pressed, only for 1 key pressed case
[4:0]	RO	5'h1F	cp	column of key pressed, only for 1 key pressed case
0xCC				
[31:16]	RO	16'h0	mkc1	column 1 key pressed, for multi key pressed case
[15:0]	RO	16'h0	mkc0	column 0 key pressed, for multi key pressed case

0xD0				
[31:16]	RO	16'h0	mkc3	column 3 key pressed, for multi key pressed case
[15:0]	RO	16'h0	mkc2	column 2 key pressed, for multi key pressed case
0xD4				
[31:16]	RO	16'h0	mkc5	column 5 key pressed, for multi key pressed case
[15:0]	RO	16'h0	mkc4	column 4 key pressed, for multi key pressed case
0xD8				
[31:16]	RO	16'h0	mkc7	column 7 key pressed, for multi key pressed case
[15:0]	RO	16'h0	mkc6	column 6 key pressed, for multi key pressed case
0xDC				
[31:16]	RO	16'h0	mkc9	column 9 key pressed, for multi key pressed case
[15:0]	RO	16'h0	mkc8	column 8 key pressed, for multi key pressed case
0xE0				
[31:16]	RO	16'h0	mkc11	column 11 key pressed, for multi key pressed case
[15:0]	RO	16'h0	mkc10	column 10 key pressed, for multi key pressed case
0xE4				
[31:16]	RO	16'h0	mkc13	column 13 key pressed, for multi key pressed case
[15:0]	RO	16'h0	mkc12	column 12 key pressed, for multi key pressed case
0xE8				
[31:16]	RO	16'h0	mkc15	column 15 key pressed, for multi key pressed case
[15:0]	RO	16'h0	mkc14	column 14 key pressed, for multi key pressed case
0xEC				
[31:16]	RO	16'h0	mkc17	column 17 key pressed, for multi key pressed case
[15:0]	RO	16'h0	mkc16	column 16 key pressed, for multi key pressed case
0xF0				
[31:16]	RW	16'h0	reserved	
[15:0]	RW	16'h0FFF	mk_in_en	enable/disable key scan inputs: 0: disable, 1: enable
0xF4				
[31:2]	RW	30'h0	reserved	
[1:0]	RW	2'b0	ks_pena_i	
0xF8				
[31:0]	RW	32'h0	ks_iosel	

4.14 Analog to Digital Converter (ADC) with Programmable Gain Amplifier (PGA)

The 12bit SAR ADC has total 10 inputs. Among them, there are two for PGA inputs, and two differential inputs for the on-chip temperature sensor. The other six inputs can be programmed to 3 pair differential inputs or six single-ended inputs. There is a manual mode with which the ADC can be configured to convert a specific input in single-ended or differential and with a specific ADC clock rate. There is also an auto sweep mode, namely all enabled input channels can be swept automatically in order by the ADC and the converted data will be stored at corresponding memory locations.

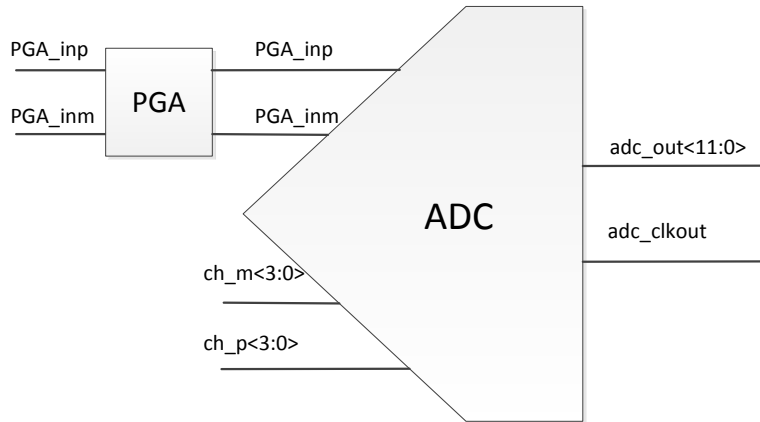

Figure 12: ADC

4.14.1 PGA Path

The PGA provides 42dB gain range from 0dB to 42dB in 3dB steps.

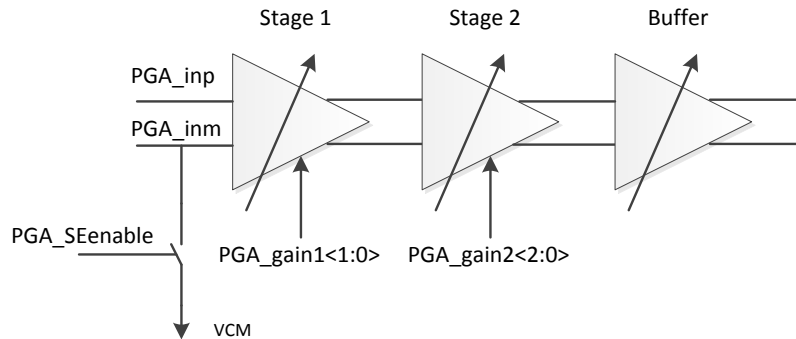

Figure 13: PGA path

pga_gain1<1>	pga_gain1<0>	Stage1 gain (dB)	pga_gain2<2>	pga_gain2<1>	pga_gain2<0>	Stage2 gain (dB)
0	0	0	0	0	0	0
0	1	12	0	0	1	3
1	0	24	0	1	0	6
			0	1	1	9
			1	0	0	12
			1	0	1	15

1 1 0 18

Table 12: PGA gain

Set PGA_SEenable to “1”, PGA will be set to Single-ended mode by pulling the PGA into its Common-mode voltage.

4.14.2 ADC Path

By default the ADC is configured in manual mode. In this mode, the ADC clock rate can be configured to 80k/160k/320k sample per second. Select the pair of inputs and configure it to differential or single-ended (positive or negative). By default it is differential. After enabling, the ADC will take samples with the configured clock rate and store the data to a channel dependent memory location. For each channel a memory size of 128Byte is allocated, when it is full an interrupt bit will be flagged. Each sample of 12bits takes 2 Byte memory space.

0x4000_F07C		Register Description
[4]	adc_ctrl_override	Set manual mode: 1: manual, 0: auto. Default 1
[3]	adc_tconv_sel	For auto mode only, adc conversion time sel: 0: 1.56us, 1: 2.34us
[2:1]	adc_clk_sel	For manual mode only, clkssel: 00: 80k, 01: 160k, 10: 320k
[0]	max_rate_256k_320k	For auto mode only, max rate base: 0, 256k, 1, 320k

0x4000_F048		Register Description
[11]	adc12b_semode_enm	For manual mode only: 12-bit ADC single-ended mode negative side enable. Bit<11> Bit<8> cannot both be 1; 1: Enable single-ended mode 0: Differential mode
[8]	Adc12b_semode_epm	For manual mode only: 12 bit ADC single-ended mode positive side enable. Bit<8> Bit<11> cannot both be 1; 1: Enable single-ended mode 0: Differential mode
[7:5]	Channel configure	For manual mode only: 12 bit ADC input channel select control bits. adc12_ctrl<3:1> Selected channel 000 PGA inputs, differential 001 Temperature sensing inputs, differential 010 input A, positive and negative 011 input B, positive and negative 100 input C, positive and negative
[3]	ADC enable	12b ADC power up control. 1: Power up ADC 0: Power down ADC

Memory start/end addresses	ADC channels
4005_0400 – 4005_047F	PAG inputs, differential
4005_0480 – 4005_04FF	Temperature sensing, differential
4005_0500 – 4005_057F	Input A, positive or differential
4005_0580 – 4005_05FF	Input A, negative

4005_0600 – 4005_067F	Input B, positive or differential
4005_0680 – 4005_06FF	Input B, negative
4005_0700 – 4005_077F	Input C, positive or differential
4005_0780 – 4005_07FF	Input C, negative

0x4005_003C	ADC interrupt status	Register Description
[7]		input C, negative
[6]		Input C, positive or differential
[5]		Input B, negative
[4]		Input B, positive or differential
[3]		Input A, negative
[2]		Input A, positive or differential
[1]		Temperature sensing, differential
[0]		PGA inputs, differential

0x4005_0038	ADC interrupt write clear	Register Description
[7]		input C, negative, write 1 to clear
[6]		Input C, positive or differential, write 1 to clear
[5]		Input B, negative, write 1 to clear
[4]		Input B, positive or differential, write 1 to clear
[3]		Input A, negative, write 1 to clear
[2]		Input A, positive or differential, write 1 to clear
[1]		Temperature sensing, differential, write 1 to clear
[0]		PGA inputs, differential, write 1 to clear

ADC can also be configured into auto channel sweep mode by setting the “adc_ctrl_override” bit to 0, with which the enabled channels will be sampled in the configured order automatically. The ten ADC input channels can be configured by programming their corresponding registers. Their configurations include sampling time, enable/disable, differential/single-ended, and continuous sampling/single-shot, based on the following register table. The sampled data is stored in the corresponding memory locations as in manual mode.

0x4000_F06C	ADC_CTL0	Register Description
[31:16]	Temperature sensing, auto mode, differential	channel config: [3:0] sample time, for max rate 320k: 2T to 62T, step 4T; for max rate 256k, 3T to 63T, step 4T, T is period of 1.28MHz; [4] channel enable; [5] differential 1 or single-ended 0; [6] continuous 0 or one shot 1. For auto channel sweep mode only
[15:0]	PGA inputs, differential	channel config: [3:0] sample time, for max rate 320k: 2T to 62T, step 4T; for max rate 256k, 3T to 63T, step 4T, T is period of 1.28MHz; [4] channel enable; [5] differential 1 or single-ended 0; [6] continuous 0 or one shot 1. For auto channel

sweep mode only

0x4000_F070	ADC_CTL1	Register Description
-------------	----------	----------------------

[31:16]	Inputs A, negative	channel config: [3:0] sample time, for max rate 320k: 2T to 62T, step 4T; for max rate 256k, 3T to 63T, step 4T, T is period of 1.28MHz; [4] channel enable; [5] differential 1 or single-ended 0; [6] continuous 0 or one shot 1. For auto channel sweep mode only
---------	--------------------	---------------------------------------------------------------------------------------------------------------------------------------------------------------------------------------------------------------------------------------------------------------------

[15:0]	Input A, positive or differential	channel config: [3:0] sample time, for max rate 320k: 2T to 62T, step 4T; for max rate 256k, 3T to 63T, step 4T, T is period of 1.28MHz; [4] channel enable; [5] differential 1 or single-ended 0; [6] continuous 0 or one shot 1. For auto channel sweep mode only
--------	-----------------------------------	---------------------------------------------------------------------------------------------------------------------------------------------------------------------------------------------------------------------------------------------------------------------

0x4000_F074	ADC_CTL2	Register Description
-------------	----------	----------------------

[31:16]	Input B, negative	channel config: [3:0] sample time, for max rate 320k: 2T to 62T, step 4T; for max rate 256k, 3T to 63T, step 4T, T is period of 1.28MHz; [4] channel enable; [5] differential 1 or single-ended 0; [6] continuous 0 or one shot 1. For auto channel sweep mode only
---------	-------------------	---------------------------------------------------------------------------------------------------------------------------------------------------------------------------------------------------------------------------------------------------------------------

[15:0]	Input B, positive or differential	channel config: [3:0] sample time, for max rate 320k: 2T to 62T, step 4T; for max rate 256k, 3T to 63T, step 4T, T is period of 1.28MHz; [4] channel enable; [5] differential 1 or single-ended 0; [6] continuous 0 or one shot 1. For auto channel sweep mode only
--------	-----------------------------------	---------------------------------------------------------------------------------------------------------------------------------------------------------------------------------------------------------------------------------------------------------------------

0x4000_F078	ADC_CTL3	Register Description
-------------	----------	----------------------

[31:16]	Input C, negative	channel config: [3:0] sample time, for max rate 320k: 2T to 62T, step 4T; for max rate 256k, 3T to 63T, step 4T, T is period of 1.28MHz; [4] channel enable; [5] differential 1 or single-ended 0; [6] continuous 0 or one shot 1. For auto channel sweep mode only
---------	-------------------	---------------------------------------------------------------------------------------------------------------------------------------------------------------------------------------------------------------------------------------------------------------------

[15:0]	Input C, positive or differential	channel config: [3:0] sample time, for max rate 320k: 2T to 62T, step 4T; for max rate 256k, 3T to 63T, step 4T, T is period of 1.28MHz; [4] channel enable; [5] differential 1 or single-ended 0; [6]
--------	-----------------------------------	--------------------------------------------------------------------------------------------------------------------------------------------------------------------------------------------------------

continuous 0 or one shot 1. For auto channel sweep mode only

Table 13: ADCchannel configurations

4.14.3 ADC Channel <3:0> Connectivity

PGA inputs	hardwired
temp sensing	hardwired
aio<0>	Input A positive
aio<1>	Input A negative
aio<2>	Input B positive
aio<3>	Input B negative
aio<4>	Input C positive
aio<9>	Input C negative

Table 15: ADC channel connectivity

Aio<9, 4:0> and PGA inputs(Aio<7:8>) can be selected through an analog Mux by programming aio_pass<7:0> or aio_attn<7:0>. For example, register 0x4000_F020<8><0> set to 01, then Aio<0> is connected to ADC input A positive node.

0x4000_F020		Register Description
[13:8]	Attenuation ctrl	attn[5:0]. analogIO control for {aio<9>, aio<4>, aio<3>, aio<2>, aio<1>, aio<0>}. {attn[x], pass[x]}: 00 switch off 01 pass 10 attenuate to 1/4 11 NC
[5:0]	pass ctrl	pass[5:0]. analogIO control for {aio<9>, aio<4>, aio<3>, aio<2>, aio<1>, aio<0>}. {attn[x], pass[x]}: 00 switch off 01 pass 10 attenuate to 1/4 11 NC note: analog IO sharing gpio<11>/aio<0> gpio<12>/aio<1> gpio<13>/aio<2> gpio<14>/aio<3> gpio<15>/aio<4> gpio<16>/aio<5>/32K XTAL input gpio<17>/aio<6>/32K XTAL output gpio<18>/aio<7>/pga in+ gpio<19>/aio<8>/pga in- gpio<20>/aio<9>/mic bias

5 Absolute Maximum Ratings

Maximum ratings are the extreme limits to which CMT4501 can be exposed without permanently damaging it. Exposure to absolute maximum ratings for prolonged periods of time may affect the reliability of the CMT4501. **Table 16** specifies the absolute maximum ratings for CMT4501.

Symbol	Parameter	Min.	Max.	Unit
Supply voltages				
VDD3		-0.3	+3.6	V
DEC			1.32	V
VSS			0	V
I/O pin voltage				
VIO		-0.3	VDD + 0.3	V
Environmental				
	Storage temperature	-40	+125	°C
MSL	Moisture Sensitivity Level		3	
ESD HBM	Human Body Model Class 2		2	kV
ESD CDMQF	Charged Device Model		500	V
Flash memory				
	Endurance		20 000	write/erase cycles
	Retention		10 years at 40 °C	
	Number of times an address can be written between erase cycles		2	times

Table 16: Absolute maximum ratings



6 Operating Conditions

The operating conditions are the physical Parameters that CMT4501 can operate within as defined in Table 17.

Symbol	Parameter	Min.	Typ.	Max.	Units
VDD3	Supply voltage, normal mode	1.8	3	3.6	V
tr_VDD	Supply rise time (0 V to 1.8 V)			100	ms
TA	Operating temperature	-40	27	125	°C

Table 17: Operating conditions

7 Radio Transceiver

7.1 Radio Current Consumption

Parameter	Description	MIN	TYP	MAX	UNIT
Tx only at 0dBm	with internal DC-DC @3V		8		mA
Rx Only	with internal DC-DC @3V		8		mA

Table 18: Radio current consumption

7.2 Transmitter Specification

Parameter	Description	MIN	TYP	MAX	UNIT
RF Max Output Power			10		dBm
RF Min Output Power			-20		dBm
OBW for BLE 1Mbps	20dB occupy-bandwidth for BLE modulation 1Mbps		1100		KHz
OBW for BLE 2Mbps	20dB occupy-bandwidth for BLE modulation 2Mbps		2300		KHz
OBW for GFSK 500Kbps	20dB occupy-bandwidth for GFSK modulation 2Mbps		1100		KHz
OBW for GFSK 125bps	20dB occupy-bandwidth for GFSK modulation 2Mbps		1100		KHz
Error Vector Measure	Offset EVM for OQPSK modulation		0.02		
FDEV for BLE 1Mbps	Frequency deviation for GFSK modulation 1Mbps	160		250	KHz
FDEV for BLE 2Mbps	Frequency deviation for GFSK modulation 2Mbps	320		500	KHz

Table 19: Transmitter specification

7.3 Receiver Specification

7.3.1 RX BLE 1Mbps GFSK

Parameter	Description	MIN	TYP	MAX	UNIT
Rx Sensitivity	Sensitivity test 1Mbps BLE ideal transmitter, 37 Byte BER=1E-3		-97		dBm
co-channel rejection	modulated interferer in channel, 37 Byte BER=1E-3		-6		I/C dB
Selectivity +-1MHz	Wanted signal at -67dBm, modulated interferer at +/- 1MHz, 37 Byte BER=1E-3		7		I/C dB
Selectivity +-2MHz	Wanted signal at -67dBm, modulated interferer at +/- 2MHz, 37 Byte BER=1E-3		45		I/C dB
Selectivity +-3MHz	Wanted signal at -67dBm, modulated interferer at +/- 3MHz, 37 Byte BER=1E-3		50		I/C dB
Selectivity +-4MHz	Wanted signal at -67dBm, modulated interferer at +/- 4MHz, 37 Byte BER=1E-3		50		I/C dB
Selectivity +-5MHz or More	Wanted signal at -67dBm, modulated interferer at >= +/- 5MHz, 37 Byte BER=1E-3		55		I/C dB
Selectivity Imag frequency	Wanted signal at -67dBm, modulated interferer at imagefrequency, 37 Byte BER=1E-3		22		I/C dB
Intermodulation	Wanted signal at 2402MHz, -64dBm, Two interferers at 2405 and 2408 MHz respectively, at the given power level, 37 Byte BER=1E-3		-20		dBm
Carrier Frequency Offset Tolerance			+/- 350		KHz
Sample Clock Offset Tolerance			+/- 120		ppm

Table 20: RX BLE 1Mbps GFSK

7.3.2 RX BLE 2Mbps GFSK

Parameter	Description	MIN	TYP	MAX	UNIT
Rx Sensitivity	Sensitivity test 2Mbps BLE ideal transmitter, 37 Byte BER=1E-3		-94		dBm
co-channel rejection	modulated interferer in channel, 37 Byte BER=1E-3		-6		I/C dB
Selectivity +-1MHz	Wanted signal at -67dBm, modulated interferer at +/- 1MHz, 37 Byte BER=1E-3		-5		I/C dB
Selectivity +-2MHz	Wanted signal at -67dBm, modulated interferer at +/- 2MHz, 37 Byte BER=1E-3		9		I/C dB
Selectivity +-3MHz	Wanted signal at -67dBm, modulated interferer at +/- 3MHz, 37 Byte BER=1E-3		30		I/C dB
Selectivity +-4MHz	Wanted signal at -67dBm, modulated interferer at +/- 4MHz, 37 Byte BER=1E-3		40		I/C dB
Selectivity +-5MHz or More	Wanted signal at -67dBm, modulated interferer at >= +/- 5MHz, 37 Byte BER=1E-3		55		I/C dB
Selectivity Imag frequency	Wanted signal at -67dBm, modulated interferer at imagefrequency, 37 Byte BER=1E-3		22		I/C dB

Intermodulation	Wanted signal at 2402MHz, -64dBm, Two interferers at 2405 and 2408 MHz respectively, at the given power level, 37 Byte BER=1E-3	-20			dBm
Carrier Frequency Offset Tolerance		+/- 350			KHz
Sample Clock Offset Tolerance		+/- 120			ppm

Table 21: RX BLE 2Mbps GFSK

7.3.3 RX 500Kbps GFSK

Parameter	Description	MIN	TYP	MAX	UNIT
Rx Sensitivity	Sensitivity test 500Kbps BLE ideal transmitter, 37 Byte BER=1E-3		-98		dBm
co-channel rejection	modulated interferer in channel, 37 Byte BER=1E-3		-4		I/C dB
Selectivity +/- 1MHz	Wanted signal at -67dBm, modulated interferer at +/- 1MHz, 37 Byte BER=1E-3		10		I/C dB
Selectivity +/- 2MHz	Wanted signal at -67dBm, modulated interferer at +/- 2MHz, 37 Byte BER=1E-3		45		I/C dB
Selectivity +/- 3MHz	Wanted signal at -67dBm, modulated interferer at +/- 3MHz, 37 Byte BER=1E-3		50		I/C dB
Selectivity +/- 4MHz	Wanted signal at -67dBm, modulated interferer at +/- 4MHz, 37 Byte BER=1E-3		50		I/C dB
Selectivity +/- 5MHz or More	Wanted signal at -67dBm, modulated interferer at >= +/- 5MHz, 37 Byte BER=1E-3		55		I/C dB
Selectivity Imag frequency	Wanted signal at -67dBm, modulated interferer at imagefrequency, 37 Byte BER=1E-3		24		I/C dB
Intermodulation	Wanted signal at 2402MHz, -64dBm, Two interferers at 2405 and 2408 MHz respectively, at the given power level, 37 Byte Ber=1E-3		-19		dBm
Carrier Frequency Offset Tolerance			+/-350		KHz
Sample Clock Offset Tolerance			+/-120		ppm

Table 22: RX 500Kbps GFSK

7.3.4 RX 125Kbps GFSK

Parameter	Description	MIN	TYP	MAX	UNIT
Rx Sensitivity	Sensitivity test 125Kbps BLE ideal transmitter, 37 Byte BER=1E-3		-103		dBm
co-channel rejection	modulated interferer in channel, 37 Byte BER=1E-3		-1		I/C dB
Selectivity +/- 1MHz	Wanted signal at -67dBm, modulated interferer at +/- 1MHz, 37 Byte BER=1E-3		-11		I/C dB
Selectivity +/- 2MHz	Wanted signal at -67dBm, modulated interferer at +/- 2MHz, 37 Byte BER=1E-3		45		I/C dB
Selectivity +/- 3MHz	Wanted signal at -67dBm, modulated interferer at +/- 3MHz, 37 Byte BER=1E-3		50		I/C dB

Selectivity +/- 4MHz	Wanted signal at -67dBm, modulated interferer at +/- 4MHz, 37 Byte BER=1E-3	50		I/C dB
Selectivity +/- 5MHz or More	Wanted signal at -67dBm, modulated interferer at >= +/- 5MHz, 37 Byte BER=1E-3	55		I/C dB
Selectivity Imag frequency	Wanted signal at -67dBm, modulated interferer at imagefrequency, 37 Byte BER=1E-3	28		I/C dB
Intermodulation	Wanted signal at 2402MHz, -64dBm, Two interferers at 2405 and 2408 MHz respectively, at the given power level, 37 Byte BER=1E-3	-18		dBm
Carrier Frequency Offset Tolerance		+/- 350		KHz
Sample Clock Offset Tolerance		+/- 120		ppm

Table 23: RX 125Kbps GFSK

7.4 RSSI Specifications

Parameter	Description	MIN	TYP	MAX	UNIT
RSSI Dynamic Range			70		dB
RSSI Accuracy	RSSI Accuracy Valid in range -100 to -30dBm		+/-2		dB
RSSI Resolution	Totally 7bit, from 0 to 127		1		dB
RSSI Period			8		us

Table 24: RSSI specifications

8 Glossary

Term	Description
AHB	Advanced High-performance Bus (ARM bus standard)
AHB-AP	DAP AHB Port for debug component access thru AHB bus
AMBA	Advanced Microcontroller Bus Architecture
AON	Always-on power domain
APB	Advanced Peripheral Bus (ARM bus standard)
APB-AP	DAP APB Port for debug component access thru APB bus
BROM	Boot ROM
DAP	Debug Access Port (ARM bus standard)
ETM	Embedded trace module
FPU	Floating Point Unit
I2C	Inter-Integrated Circuit
I2S	Inter-IC Sound, Integrated Interchip Sound
ITM	Instrumentation Trace Macrocell Unit
JTAG	Joint Test Access Group (IEEE standard)
JTAG-AP	DAP's JTAG Access Port to access debug components
JTAG-DP	DAP's JTAG Debug Port used by external debugger
J&M	Jun and Marty LLC
MPU	Memory Protection Unit
NVIC	Nested vector Interrupt Controller
PCR	Power Clock Reset controller
POR	Power on reset, it is active low in this document
RFIF	APB peripheral to interface RF block
SWD	Serial Wire DAP (ARM bus standard)
SoC	System on chip
SPI	Serial Peripheral Interface
SRAM	Static Random Access memory
TWI	Two-Wire Interface
UART	Universal Asynchronous Receiver and Transmitter
WDT	Watchdog Timer

Table 25: Glossary

9 Ordering information

Part No.	Package	Packing	MOQ(PCS)
CMT4501AAQA	QFN32	Tray	490
	QFN32	Tape&Reel	4500

10 Chip Marking

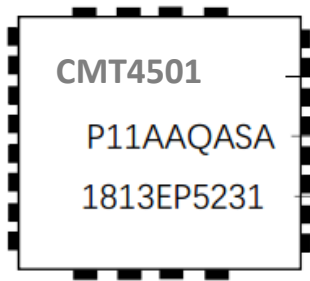

- 45** --4500 series
- 02** -- M0 processor
- P11** -- CMT internal wafer version
- AA** --CMT internal setting
- QA** --Package QA --QFN32
- S** -- CMT foundry ID
- A** -- CMT assembly house ID
- 18** --Year of date code
- 13** --Week of date code
- EP5231** --lot number

11 Package dimensions

QFN32 package dimensions:

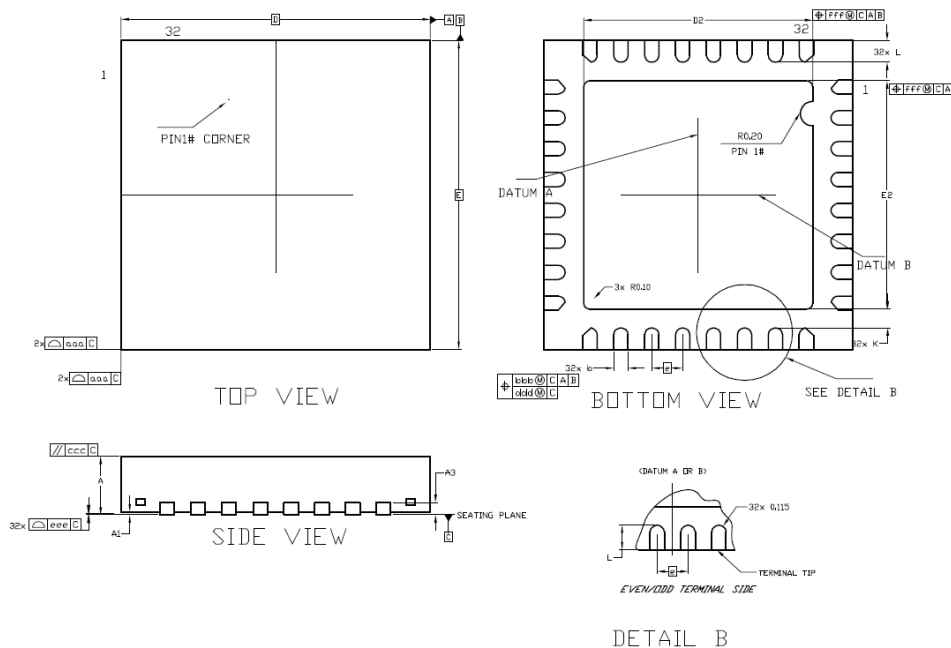

DIM SYMBOL	MIN.	NOM.	MAX.
A	0.70	0.75	0.80
A1	0.85	0.90	0.95
A3	0	0.02 REF	0.05
b	0.18	0.23	0.28
D	5.00BSC		
E	5.00BSC		
D2	3.55	3.65	3.75
E2	3.55	3.65	3.75
e	0.50BSC		
L	0.30	0.35	0.40
K	0.20	-	-
aaa	0.15		
bbb	0.10		
ccc	0.10		
ddd	0.05		
eee	0.08		
fff	0.10		

NOTES:
1. DIMENSIONING AND TOLERANCING CONFIRM TO ASME Y14.5M-1994

Note: dimensions are in mm, angels are in degree.

12 Sample Application and Layout Guide

1) Sample Application

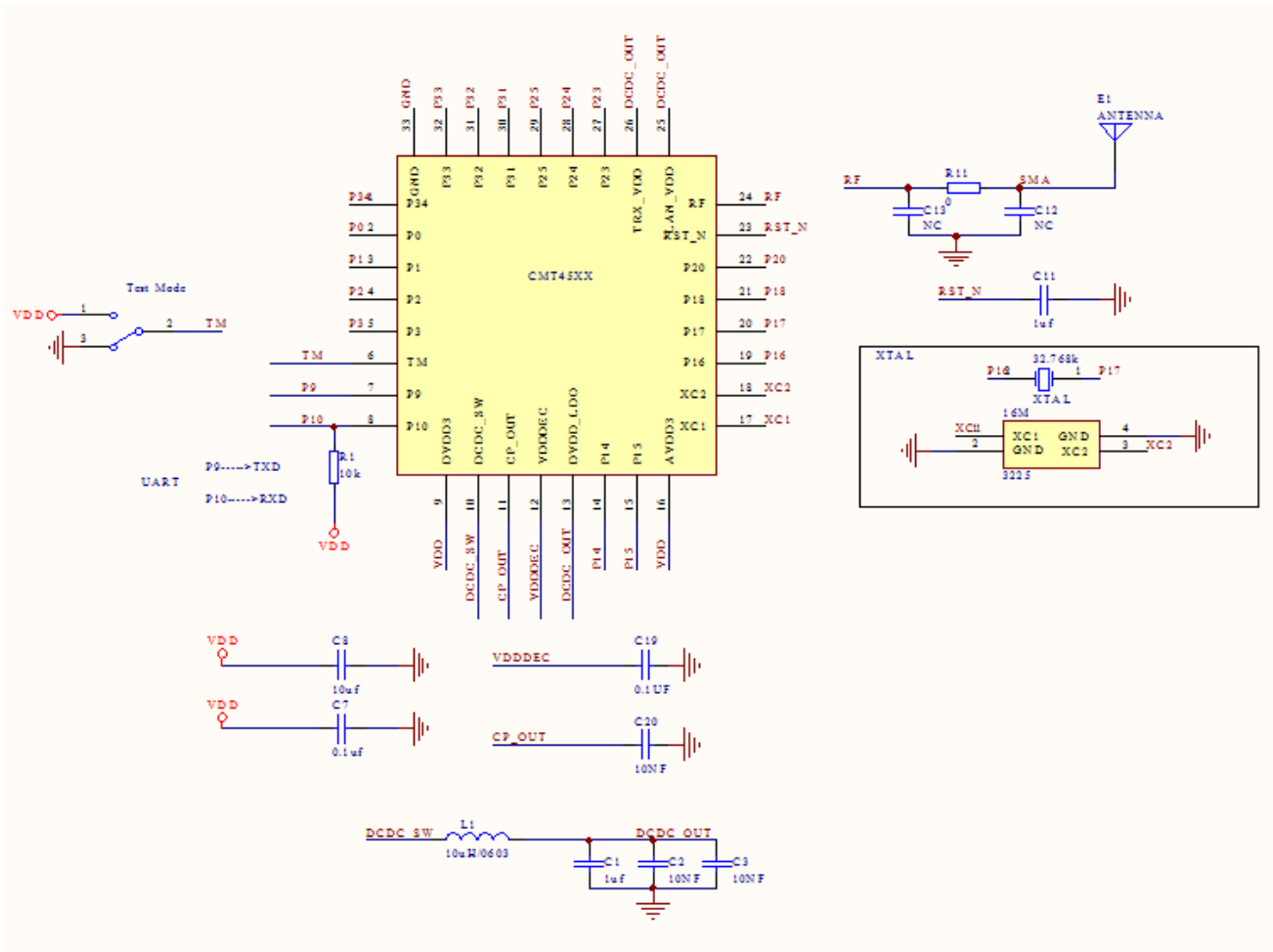

2) Layout Guide

Placement

1. RF matching/Loop filter leading to antenna should be isolated from any other AC/DC signal as much as possible;
2. Xtal/OSC clock is a noise source to other circuits, keep clock trace as short as possible and away from any important area;
3. LDO's are sensitive and could be easily contaminated, care should be taken for the environment;
4. Antenna is the main RF radiation point, other important blocks should be shielded or away from this area.

RF traces

1. Define RF line width with given dielectric thickness (thickness of PCB dielectric layer to ground plane) to achieve 50ohm impedance; this is mainly for the RF line connecting to matching/loop filter and antenna.
2. Differential traces should be kept in the same length and component should be placed symmetrically;
3. Certain length of RF trace should be treated as part of RF matching.

Bypass Capacitor

1. Each VDD pin needs a bypass capacitor to release chip internal noise and block noise from power supply.

2. For power traces, bypass capacitors should be placed as close as possible to VDD pins.
3. Use one large and one small capacitor when the pin needs two capacitors. Typically the capacitance of the larger capacitor is about 100 times of that of the smaller one. The smaller capacitor usually has better quality factor than the larger one. Place the larger capacitor closer to the pin.
4. The capacitors of Loop filter need to have larger clearance to prevent EMC/EMI issue.
5. Ground via should be close to the Capacitor GND side, and away from strong signals.

Layer Definition

1. Normally 4 layer PCB is recommended.
2. RF trace must be on the surface layer, i.e. top layer or bottom.
3. The second layer of RF PCB must be "Ground" layer, for both signal ground and RF reference ground, DO NOT put any other trace or plane on second layer, otherwise "antenna effect" will complicate debug process.
4. Power plane generally is on the 3rd layer.
5. Bottom layer is for "signal" layer.
6. If two layer PCB is used, quality will degrade in general. More care needs to be taken. Try to maximize ground plane, avoid crossing of signal trace with other noise lines or VDD, shield critical signal line with ground plane, maximize bypass capacitor and number of ground vias.

Reference clock and trace

1. Oscillator signal trace is recommended to be on the 1st layer;
2. DO NOT have any trace around or across the reference clock (oscillator) trace.
3. Isolate the reference clock trace and oscillator by having more GND via around.
4. DO NOT have any other traces under the Oscillator.

Power line or plane

1. Whether to use power plain or power line depend on the required current, noise and layout condition. For RF chip, we generally suggest to use power line to bring power into IC pin. Line has parasitic inductance, which forms a low pass filter to reduce the noise traveling around PCB.
2. Add more conductive via on the current source, it will increase max current limit and reduce inductance of via.
3. Add some capacitor alone the power trace when power line travels a long distance.
4. DO NOT place power line or any plane under RF trace or oscillator and its clock trace, the strong clock or RF signal would travel with power line.

Ground Via

1. Ground Via must be as close to the ground pad of bypass capacitor as possible, too much distance between via and ground pad will reduce the effect of bypass capacitor.
2. Having as many ground via as possible.
3. Place ground via around RF trace, the RF trace should be shielded with via trail.

Contact Details

Shenzhen Office

CMOSTEK Microelectronics Co., Ltd. Shenzhen Branch

Address: Room 202-203, Honghai Building, Qianhai Road, Nanshan District, Shenzhen, Guangdong, China

Post Code: 518052

Tel: +86-755-83235017

Fax: +86-755-82761326

E-mail: sales@cmostek.com

Hope Microelectronics Co., Ltd

Address: 2/F, Building 3, Pingshan Private Enterprise Science and Technology Park, Xili Town, Nanshan District, Shenzhen, China

Tel: +86-755-82973805

Fax: +86-755-82973550

Email: sales@hoperf.com

hoperf@gmail.com

Website: <http://www.hoperf.com>

<http://www.hoperf.cn>