High Sensitivity Digital-Unipolar Hall-effect Sensor

FEATURES

- Digital Unipolar Hall-Effect sensor
- High chopping frequency
- Very high sensitivity
- Superior temperature stability
- Supports a wide voltage range
 - 2.5 to 24V
 - Operating from unregulated supply
- Reverse battery protection (up to 28V)
- Over-voltage protection at all pins
- Robust EMC performance
- Solid-state reliability
- Small package
 - 3-pin SOT23 -(SO)

APPLICATIONS

- Flow meters
- Valve and solenoid status
- BLDC motors with sensors
- Proximity sensing
- Tachometers

DESCRIPTION

The SC245X family, produced with BiCMOS technology, is a chopper-stabilized Hall Effect Sensor that offers a magnetic sensing solution with superior sensitivity stability over temperature and integrated protection features.

Superior high-temperature performance is made possible through dynamic offset cancellation, which reduces the residual offset voltage normally caused by device over molding, temperature dependencies, and thermal stress. Each device includes on a single silicon chip a voltage regulator, Hall-voltage generator, small-signal amplifier, chopper stabilization, Schmitt trigger, and an open-drain output to sink up to 20mA.

An onboard regulator permits with supply voltages of 2.5 to 24V which makes the device suitable for a wide range of industrial and automotive applications

The SC2455 is available in SOT23-3 surface mount package. package is lead (Pb) free, with 100% matte tin lead frame plating.



CONTENTS

FEATURES	- 1 -	<i>Magnetic Characteristics</i>	- 6 -
APPLICATIONS	- 1 -	TYPICAL CHARACTERISTIC	- 7 -
DESCRIPTION	- 1 -	TYPICAL CHARACTERISTIC (Continued)	- 8 -
BLOCK DIAGRAM	- 3 -	FUNCTIONAL DESCRIPTION	- 9 -
ORDERING INFORMATION	- 3 -	<i>Field Direction Definition</i>	- 9 -
TERMINAL CONFIGURATION	- 4 -	<i>Transfer function</i>	- 10 -
ABSOLUTE MAXIMUM RATINGS	- 5 -	TYPICAL APPLICATION	- 11 -
ESD PROTECTION	- 5 -	PACKAGE INFORMATION (SO)	- 12 -
THERMAL CHARACTERISTICS	- 5 -	REVISION HISTORY	- 13 -
OPERATING CHARACTERISTICS	- 6 -		
<i>Electrical Characteristics</i>	- 6 -		

BLOCK DIAGRAM

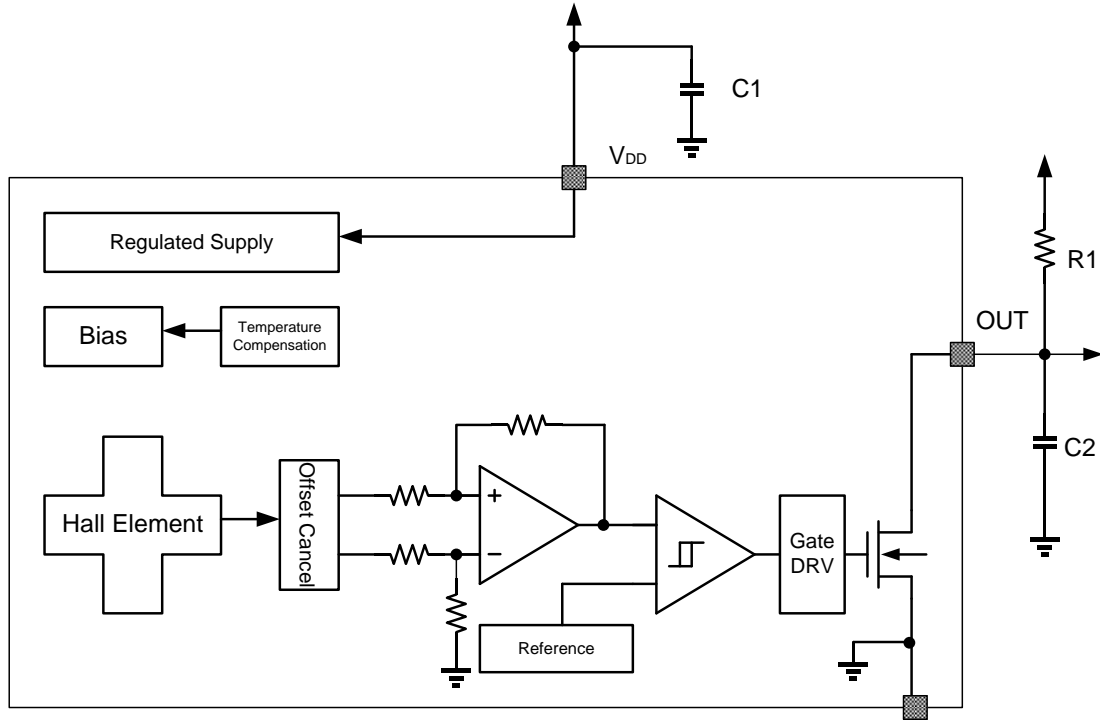

ORDERING INFORMATION

Part Number	Packing	Mounting	Ambient, T _A	B _{OP} (Typ.)	B _{RP} (Typ.)
SC2455SO	Reel, 3000pieces/reel	SOT-23	-40°C to 150°C	+25.5mT	+20.0mT
SC2455SO-N	Reel, 3000pieces/reel	SOT-23		-25.5mT	-20.0mT

TERMINAL CONFIGURATION

3-Terminal SOT-23 SO Package (Top View)

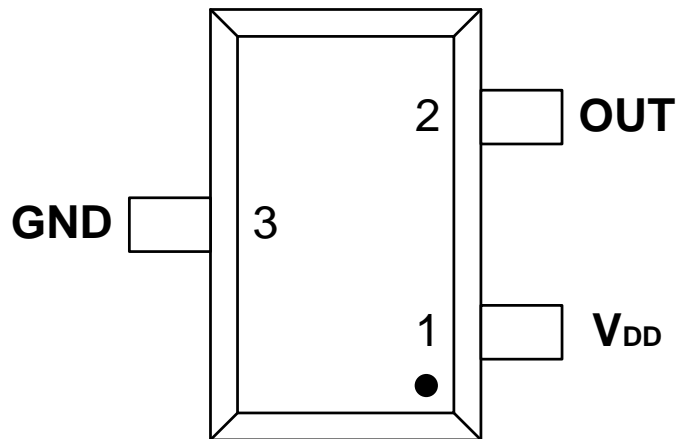

Terminal			Type	Description
Name	Number			
	UA	SO		
V _{DD}	1	1	PWR	2.5V ~ 24 V power supply
GND	2	3	Ground	Ground terminal
OUT	3	2	Output	Open-drain output

ABSOLUTE MAXIMUM RATINGS

over operating free-air temperature range (unless otherwise noted) ⁽¹⁾

Parameter	Symbol	Min.	Max.	Units
Power supply voltage	V _{DD}	-28 ⁽²⁾	28	V
Output terminal voltage	V _{OUT}	-0.5	28	V
Output terminal current sink	I _{SINK}	0	30	mA
Operating ambient temperature	T _A	-40	150	°C
Maximum junction temperature	T _J	-55	165	°C
Storage temperature	T _{STG}	-65	175	°C

⁽¹⁾ Stresses above those listed here may cause permanent damage to the device. Exposure to absolute maximum rating conditions for extended periods may affect device reliability.

⁽²⁾ Ensured by design.

ESD PROTECTION

Human Body Model (HBM) tests according to: standard AEC-Q100-002

Parameter	Symbol	Min.	Max.	Units
ESD-Protection	V _{ESD}	-4	4	kV

THERMAL CHARACTERISTICS

Symbol	Parameter	Test Conditions	Rating	Units
R _{θJA}	SO Package thermal resistance	Single-layer PCB, with copper limited to solder pads	228	°C/W

OPERATING CHARACTERISTICS

Electrical Characteristics

over operating free-air temperature range ($V_{DD} = 5.0V$, unless otherwise noted)

Symbol	Parameter	Test Conditions	Min.	Typ.	Max.	Units
V_{DD}	Operating voltage ⁽¹⁾	$T_J < T_{J(Max.)}$	2.5	--	24	V
V_{DDR}	Reverse supply voltage		-28	--	--	V
I_{DD}	Operating supply current	$V_{DD}=2.5$ to 24 V, $T_A=25^\circ C$	0.8	1.6	2.0	mA
		$V_{DD}=2.5$ to 24 V, $T_A=125^\circ C$	0.8	1.8	2.0	mA
t_{on}	Power-on time		--	35	50	μS
I_{QL}	Off-state leakage current	Output Hi-Z	--	--	3	μA
$R_{DS(on)}$	FET on-resistance	$V_{DD}=5V$, $I_o=10mA$, $T_A=25^\circ C$	--	20	--	Ω
		$V_{DD}=5V$, $I_o=10mA$, $T_A=125^\circ C$	--	30	--	Ω
t_d	Output delay time	$B=B_{RP}$ to B_{OP}	--	15	25	μS
t_r	Output rise time (10% to 90%)	$R1=1Kohm$ $Co=50pF$	--	--	0.5	μS
t_f	Output fall time (90% to 10%)	$R1=1Kohm$ $Co=50pF$	--	--	0.2	μS

⁽¹⁾ Maximum voltage must be adjusted for power dissipation and junction temperature, see Thermal Characteristics

Magnetic Characteristics

over operating free-air temperature range (unless otherwise noted)

Symbol	Parameter	Test Conditions	Min.	Typ.	Max.	Units
f_{BW}	Bandwidth		20	--	--	kHz
B_{OP}	Operated point	$T_A=-40^\circ C$ to $125^\circ C$	23.5	25.5	27.5	mT
B_{RP}	Release point		18.0	20.0	22.0	mT
B_{HYS}	Hysteresis		--	5.5	--	mT

$1mT=10Gs$

Magnetic flux density, B , is indicated as a negative value for North-polarity magnetic fields, and as a positive value for South-polarity magnetic fields.

TYPICAL CHARACTERISTIC

I_{DD} vs V_{DD}

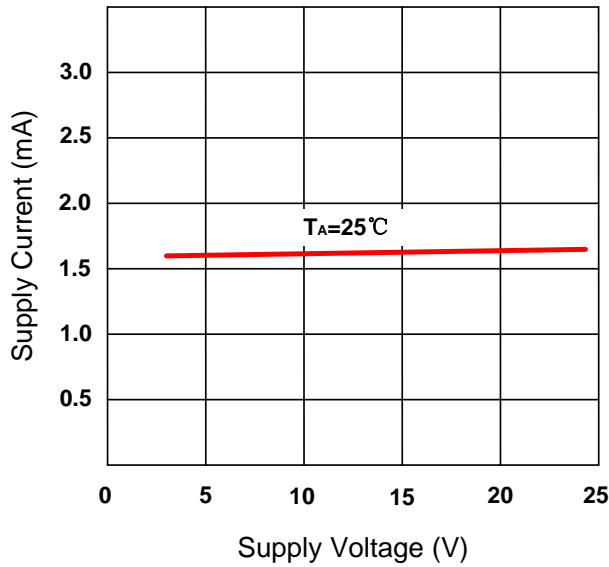

I_{DD} vs T_A

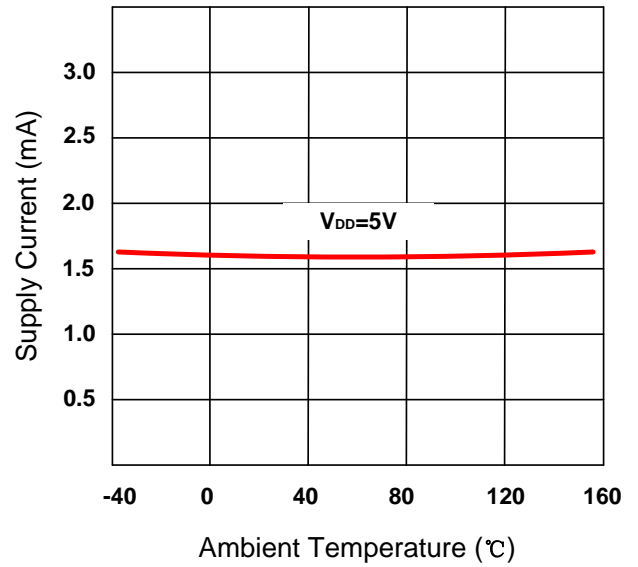

$V_{Q(sat)}$ vs V_{DD}

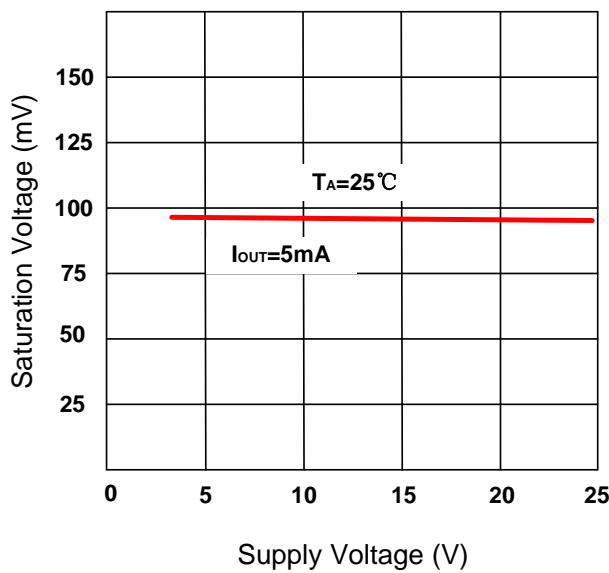

$V_{Q(sat)}$ vs T_A

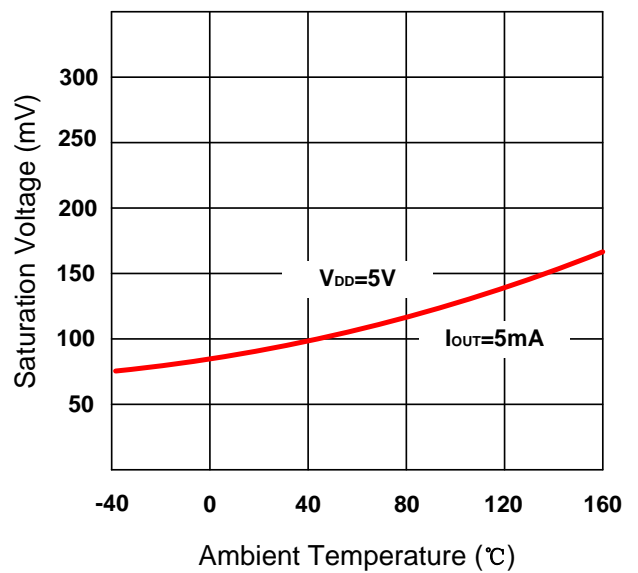

TYPICAL CHARACTERISTIC (Continued)

SC2455
B_{OP} and B_{RP} vs T_A

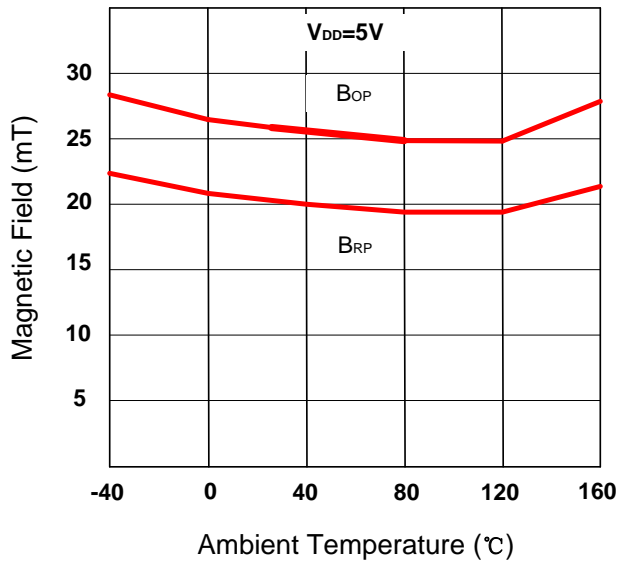

SC2455
B_{HYS} vs T_A

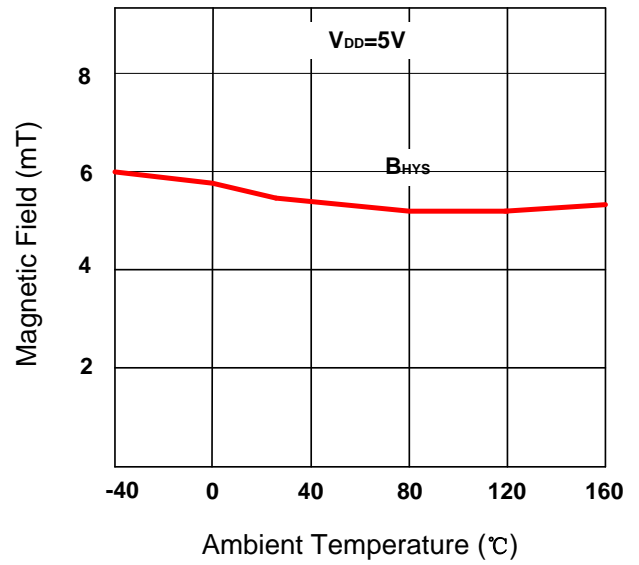

FUNCTIONAL DESCRIPTION

The SC2455 device is a chopper-stabilized Hall sensor with a digital latched output for magnetic sensing applications. The device can be powered with a supply voltage between 2.5 and 24V, and continuously survives continuous -28V reverse-battery conditions. The device does not operate when -28 to 2.2V is applied to the V_{DD} terminal (with respect to the GND terminal). In addition, the device can withstand voltages up to 40V for transient durations.

The output of SC2455 switches low (turns on) when a magnetic field (South or North polarity) perpendicular to the Hall element exceeds the operate point threshold, B_{OP} . After turn-on, the output is capable of sinking 20mA and the output voltage is $V_{Q(sat)}$. When the magnetic field is reduced below the release point, B_{RP} , the device output goes high (turns off). The difference in the magnetic operate and release points is the hysteresis, B_{HYS} , of the device. This built-in hysteresis allows clean switching of the output even in the presence of external mechanical vibration and electrical noise.

An external output pull-up resistor is required on the OUT terminal. The OUT terminal can be pulled up to V_{DD} or to a different voltage supply. This allows for easier interfacing with controller circuits.

Field Direction Definition

A positive magnetic field is defined as a South pole near the marked side of the package.

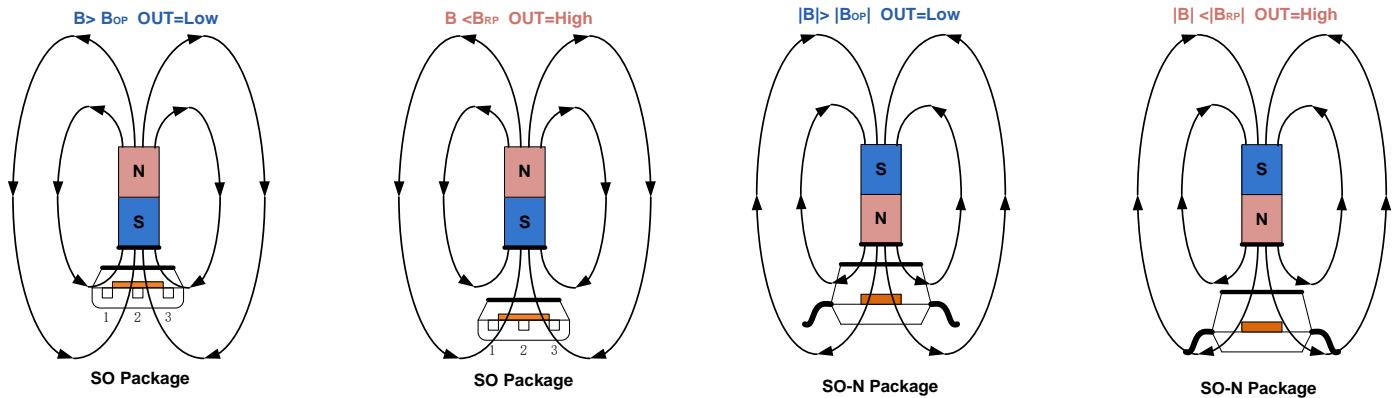

Transfer function

Powering-on the device in the hysteresis region, less than B_{OP} and higher than B_{RP} , allows an indeterminate output state. The correct state is attained after the first excursion beyond B_{OP} or B_{RP} . If the field strength is greater than B_{OP} , then the output is pulled low. If the field strength is less than B_{RP} , the output is released.

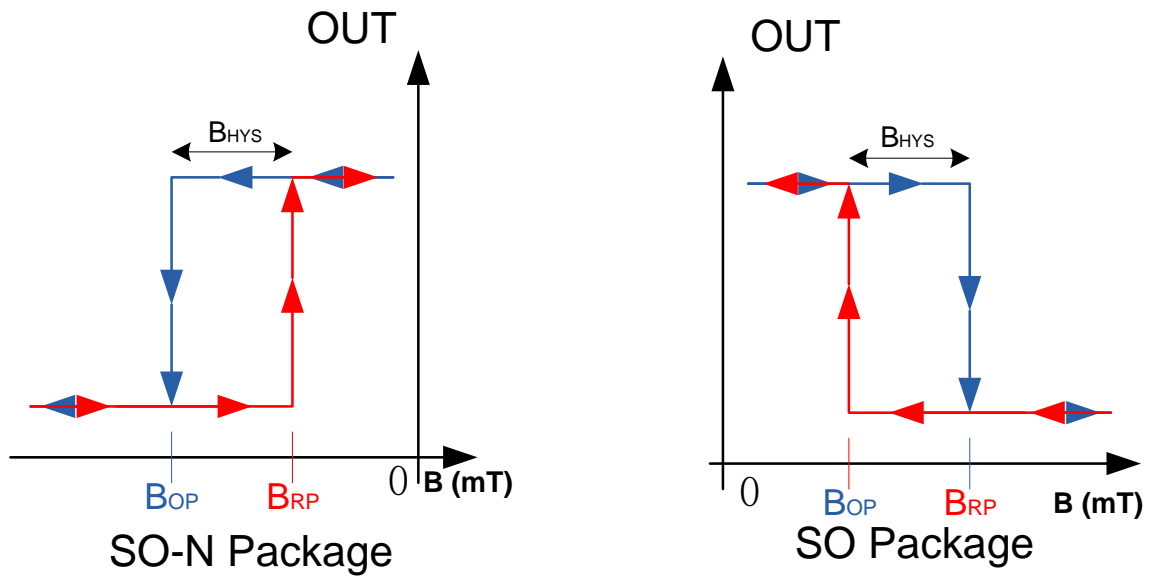

TYPICAL APPLICATION

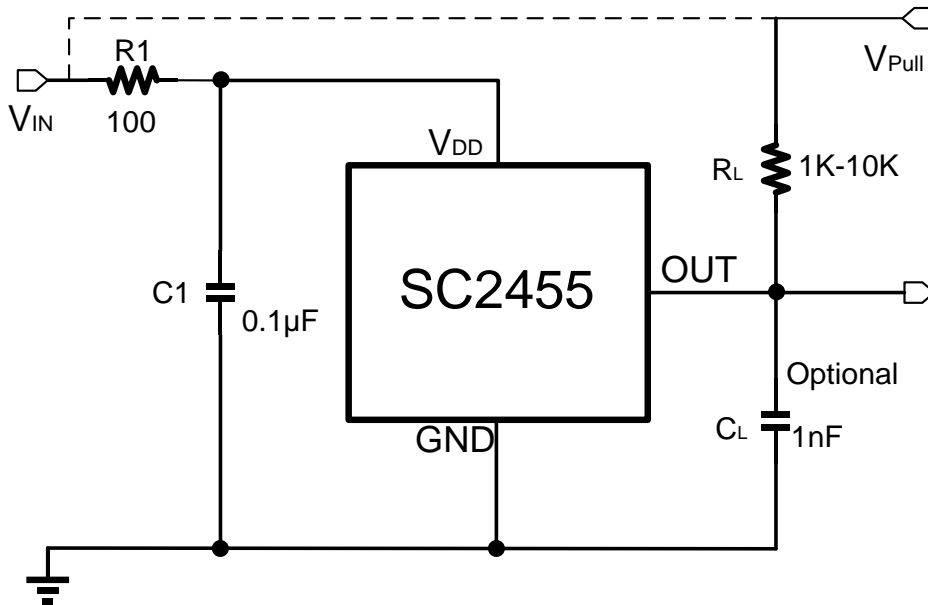

The SC2455 contains an on-chip voltage regulator and can operate over a wide supply voltage range. In applications that operate the device from an unregulated power supply, transient protection must be added externally. For applications using a regulated line, EMI/RFI protection may still be required. It is recommended to shunt C1 capacitors to the ground near the chip V_{DD} power supply, with a typical value of 0.1 μF. At the same time in the external optional series resistor R1 their typical values for 100 Ω. The output capacitor C_L is used as the output filter, typically 1 nF.

Select a value for C_L based on the system bandwidth specifications as:

$$C_L = \frac{1}{2\pi \times R \times f \text{ (Hz)}}$$

The output stage of the SC2455 device is a drain open-circuit NMOS tube, which provides a load capacity of 20mA. Adjust the pull-up resistor R_L to make it work properly. The R_L provides a high level for the leak-opening output. In general, less current is better, but faster transient response and bandwidth are required, with a smaller resistor R_L for faster switching.

V_{PULL} is not restricted to V_{DD}, and could be connected to other voltage reference. The allowable voltage range of this terminal is specified in the Absolute Maximum Ratings.

PACKAGE INFORMATION (SO)

**3-Terminal
SO Package**

Dimension:mm

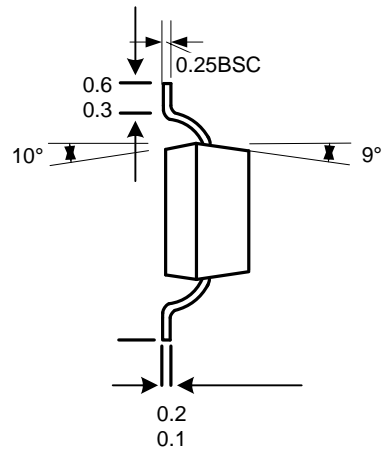
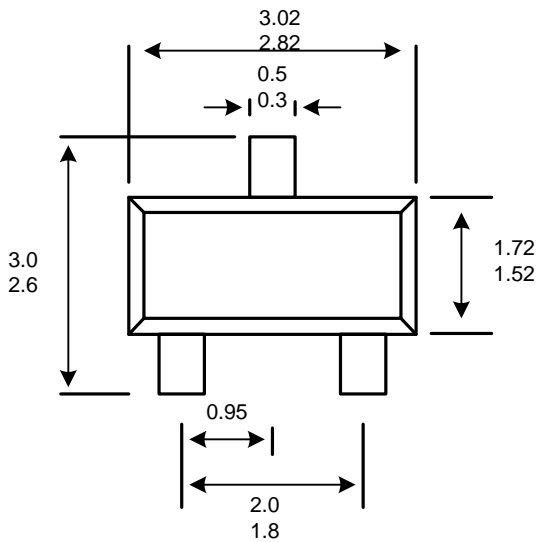
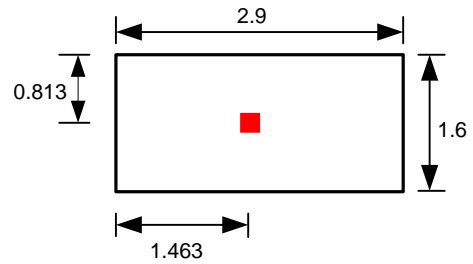
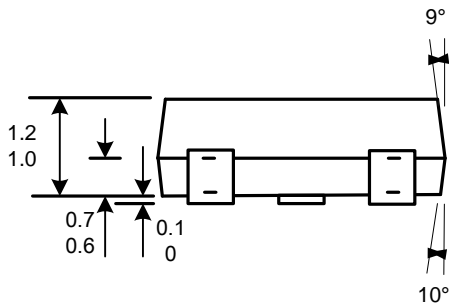

Notes:

1. Exact body and lead configuration at vendor's option within limits shown.
2. Height does not include mold gate flash.

Where no tolerance is specified, dimension is nominal.

REVISION HISTORY

Revision	Date	Description
Rev0.1	2018-07-18	Preliminary datasheet
Rev2.3	2019-11-10	The final revision of old datasheet
RevA/1.0	2020-11-19	Unified datasheet format