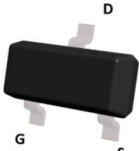
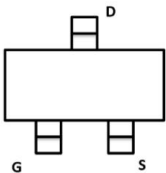
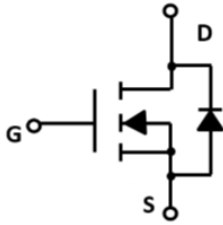

<p>Features</p> <ul style="list-style-type: none"> • 30V, 3.6A • $R_{DS(ON)} = 39m\Omega$ (Max.) @ $V_{GS} = 10V, I_D = 3.6A$ • High Power and Current Handling Capability • Lead Free Product is Acquired • Surface Mount Package 	<p>Application</p> <ul style="list-style-type: none"> • PWM Application • Load Switch • Power Management
--	--

Package

SOT-23
SFY2304AT

Absolute Maximum Ratings $T_C=25^\circ C$ unless otherwise specified

Symbol	Parameter	Max.	Units	
V_{DSS}	Drain-Source Voltage	30	V	
V_{GSS}	Gate-Source Voltage	± 20	V	
I_D	Continuous Drain Current	$T_C = 25^\circ C$	3.6	A
		$T_C = 70^\circ C$	2.9	A
I_{DM}	Pulsed Drain Current ^{note1}	15	A	
P_D	Power Dissipation	$T_C = 25^\circ C$	1.0	W
$R_{\theta JA}$	Thermal Resistance, Junction to Ambient	125	$^\circ C/W$	
T_J, T_{STG}	Operating and Storage Temperature Range	-55 to +150	$^\circ C$	

*Drain current limited by maximum junction temperature

Electrical Characteristics $T_c=25^\circ\text{C}$ unless otherwise specified

Symbol	Parameter	Test Condition	Min.	Typ.	Max.	Units
Off Characteristic						
$V_{(BR)DSS}$	Drain-Source Breakdown Voltage	$V_{GS} = 0V, I_D = 250\mu A$	30	-	-	V
I_{DSS}	Zero Gate Voltage Drain Current	$V_{DS} = 30V, V_{GS} = 0V$	-	-	1	μA
I_{GSS}	Gate to Body Leakage Current	$V_{DS} = 0V, V_{GS} = \pm 20V$	-	-	± 100	nA
On Characteristics						
$V_{GS(th)}$	Gate Threshold Voltage	$V_{DS} = V_{GS}, I_D = 250\mu A$	1.0	1.5	2.2	V
$R_{DS(on)}$	Static Drain-Source On-Resistance ^{note2}	$V_{GS} = 10V, I_D = 3.6A$	-	30	39	m Ω
		$V_{GS} = 4.5V, I_D = 3A$	-	40	52	
Dynamic Characteristics						
C_{iss}	Input Capacitance	$V_{DS} = 15V, V_{GS} = 0V,$ $f = 1.0MHz$	-	390	-	pF
C_{oss}	Output Capacitance		-	67	-	pF
C_{rss}	Reverse Transfer Capacitance		-	41	-	pF
Q_g	Total Gate Charge	$V_{DD} = 15V, I_D = 3.6A,$ $V_{GS} = 4.5V$	-	4.2	-	nC
Q_{gs}	Gate-Source Charge		-	1.0	-	nC
Q_{gd}	Gate-Drain("Miller") Charge		-	1.3	-	nC
Switching Characteristics						
$t_{d(on)}$	Turn-On Delay Time	$V_{DD} = 15V, R_L = 3.6\Omega,$ $R_{GEN} = 6\Omega, V_{GS} = 4.5V$	-	11	-	ns
t_r	Turn-On Rise Time		-	4.8	-	ns
$t_{d(off)}$	Turn-Off Delay Time		-	14	-	ns
t_f	Turn-Off Fall Time		-	9	-	ns
Drain-Source Diode Characteristics and Maximum Ratings						
I_S	Maximum Continuous Drain to Source Diode Forward Current	-	-	3.6	-	A
I_{SM}	Maximum Pulsed Drain to Source Diode Forward Current	-	-	15	-	A
V_{SD}	Drain to Source Diode Forward Voltage	$V_{GS} = 0V, I_S = 3.6A$	-	-	1.2	V

Notes:

1. Repetitive Rating: Pulse width limited by maximum junction temperature
2. Pulse width $\leq 300\mu s$; duty cycle $\leq 2\%$.

Typical Performance Characteristics

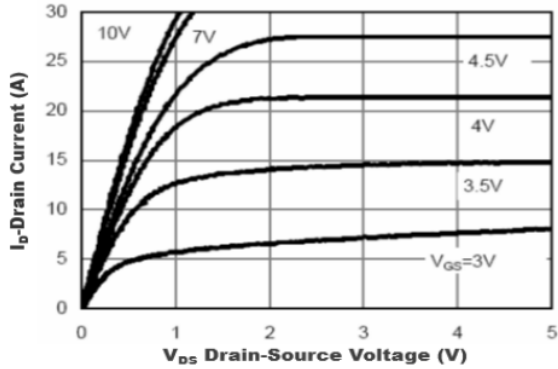

Figure 1. Output Characteristics

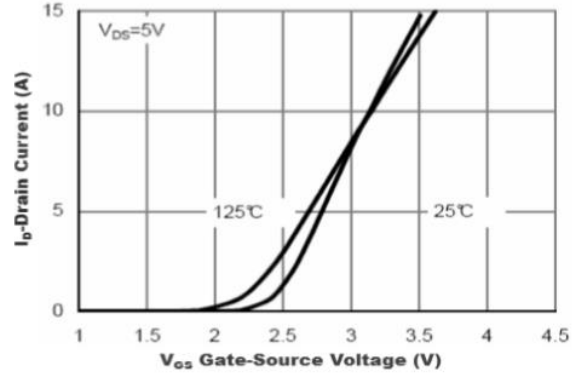

Figure 2. Transfer Characteristics

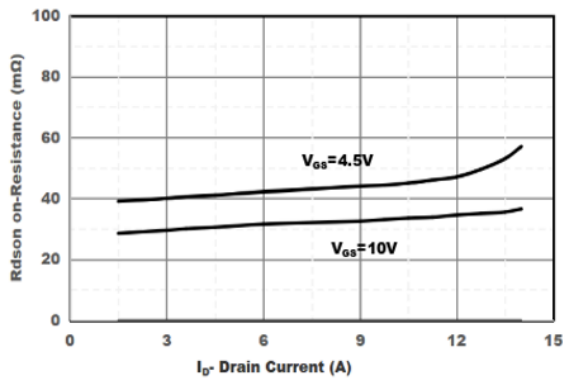

Figure 3. Drain-to-Source On Resistance

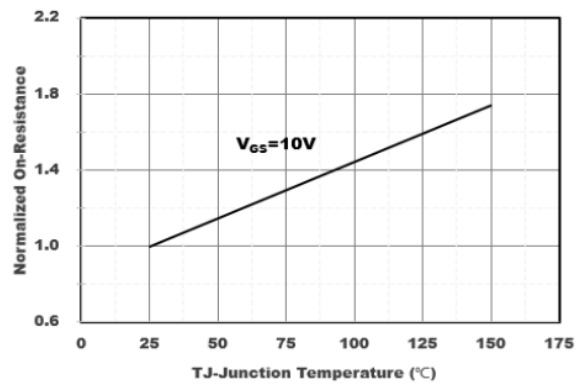

Figure 4. Drain-to-Source On Resistance

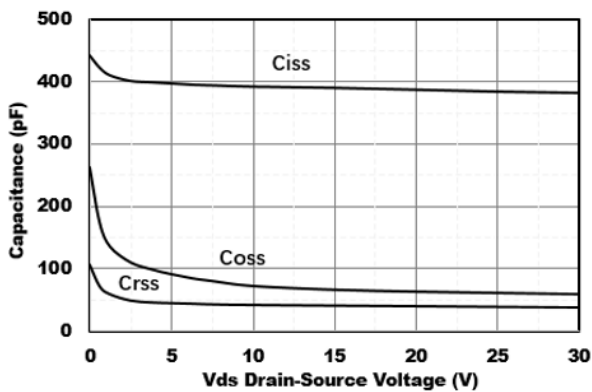

Figure 5. Capacitance Characteristics

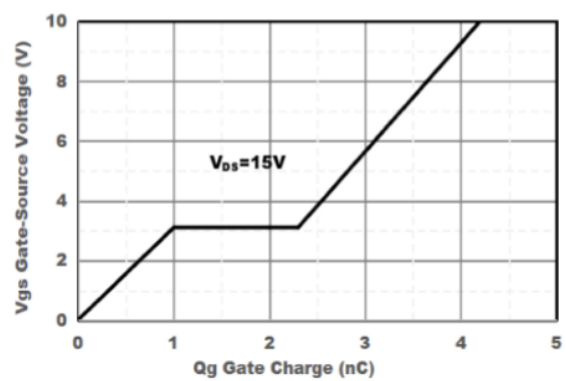

Figure 6. Gate Charge Characteristics

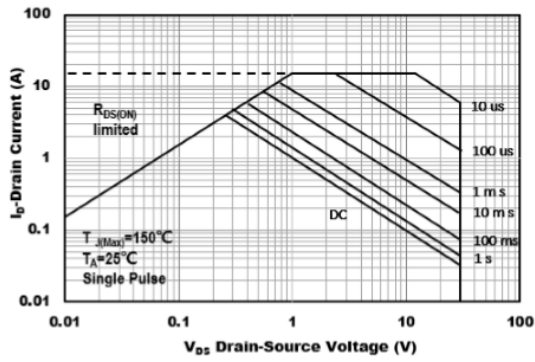

Figure 7. Maximum Safe Operating Area

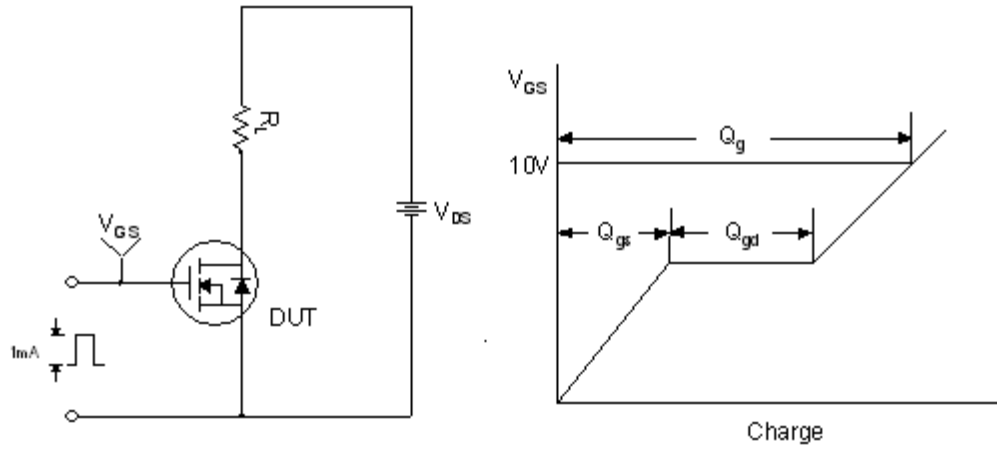

Figure 8. Gate Charge Test Circuit & Waveform

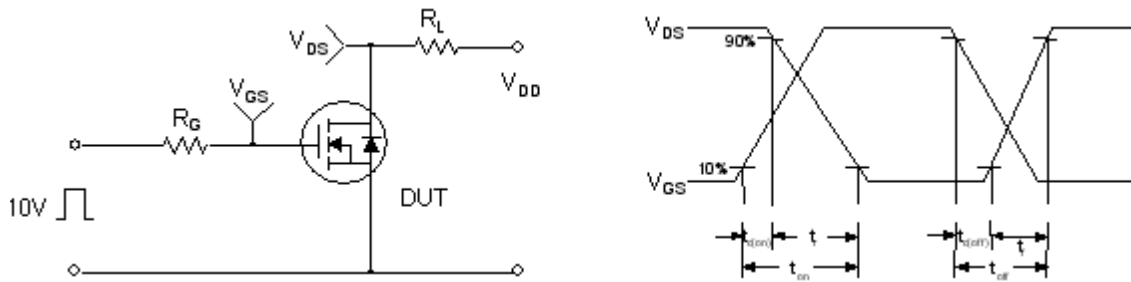

Figure 9. Resistive Switching Test Circuit & Waveforms

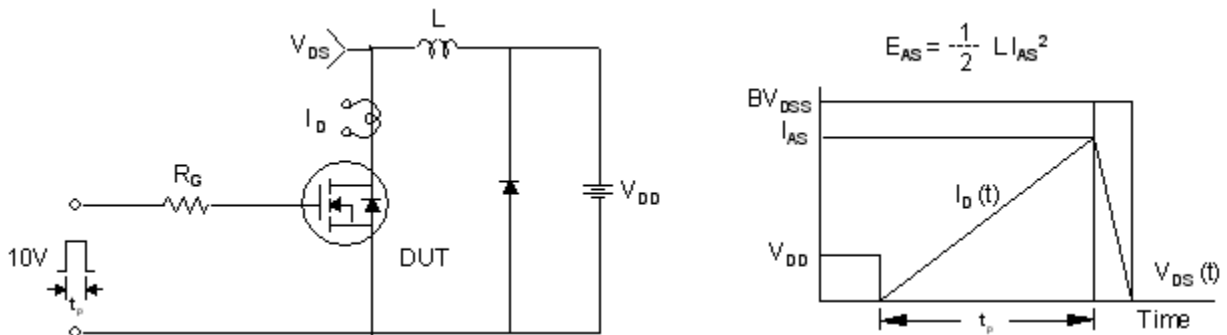

Figure 10. Unclamped Inductive Switching Test Circuit & Waveforms

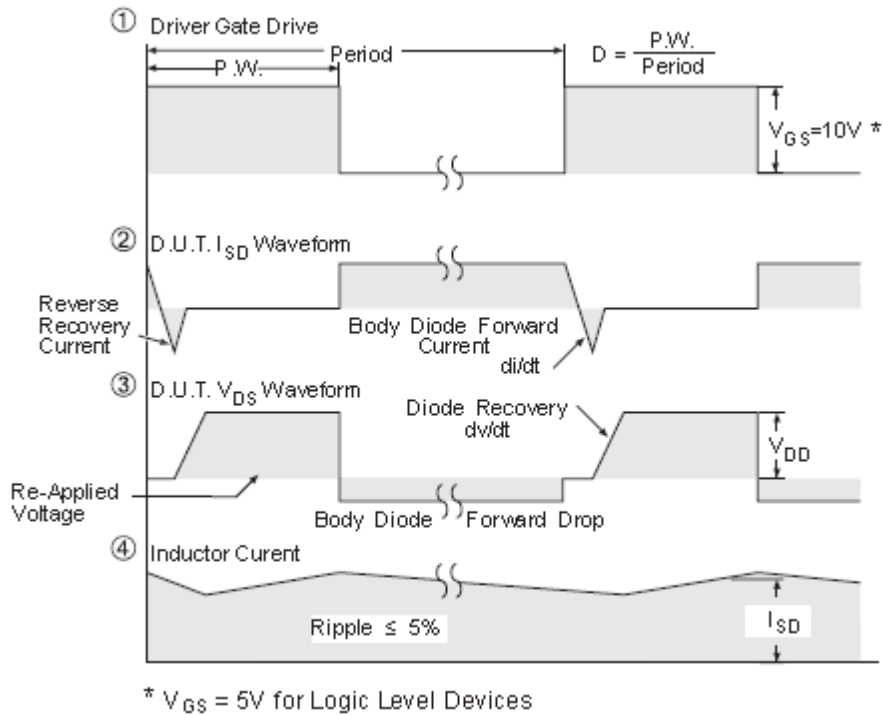
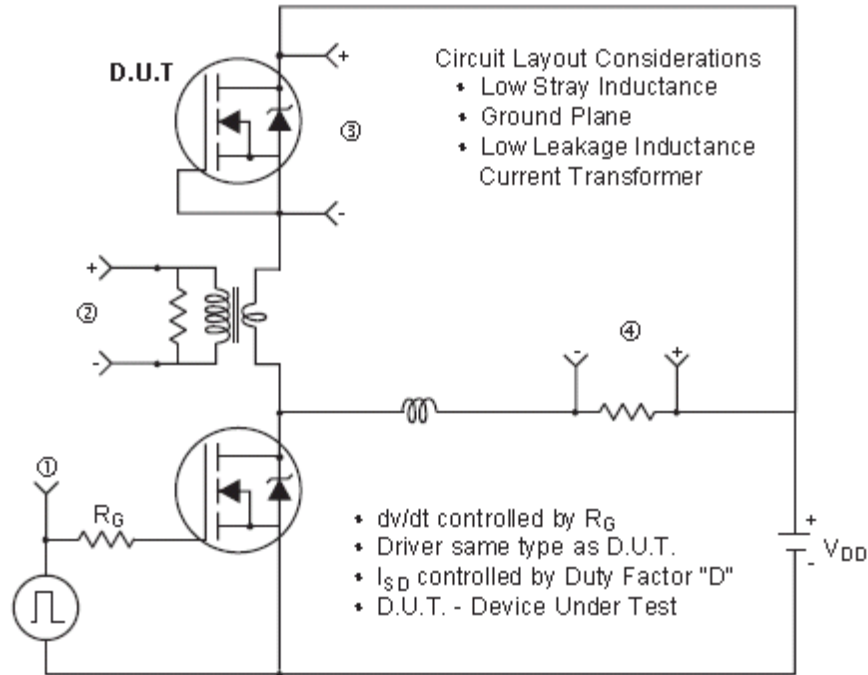
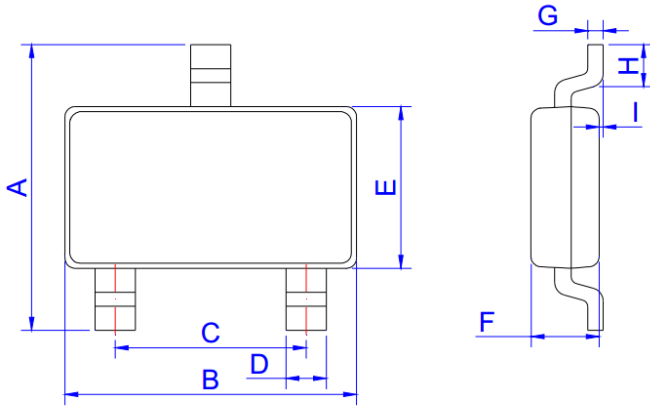

Figure 11. Peak Diode Recovery dv/dt Test Circuit & Waveforms (For N-channel)



SOT-23

Ref.	Dimensions					
	Millimeters			Inches		
	Min.	Typ.	Max.	Min.	Typ.	Max.
A	2.30	2.40	2.50	0.091	0.095	0.098
B	2.80	2.90	3.00	0.110	0.114	0.118
C	1.90 REF			0.075 REF		
D	0.35	0.40	0.45	0.014	0.016	0.018
E	1.20	1.30	1.40	0.047	0.051	0.055
F	0.90	1.00	1.10	0.035	0.039	0.043
G		0.10	0.15		0.004	0.006
H	0.20			0.008		
I	0		0.10	0		0.004

SFY2304AT Product Description

Silicon N-Channel MOSFET



NOTE:

1. We strongly recommend customers check carefully on the trademark when buying our product, if there is any question, please don't be hesitate to contact us.
2. Please do not exceed the absolute maximum ratings of the device when circuit designing.
3. Winsemi Microelectronics Co., Ltd reserved the right to make changes in this specification sheet and is subject to change without prior notice.

CONTACT:

Winsemi Microelectronics Co., Ltd.

ADD: Room 1002, East, Phase 2, HighTech Plaza, Tian-An Cyber Park, Che gong miao, FuTian, Shenzhen, P.R. China.

Post Code : 518040

Tel : +86-755-8250 6288

FAX : +86-755-8250 6299

Web Site : www.winsemi.com