

## Boost Power Factor Corrector LED Driver Power Switch

### FEATURES

- Low Cost Boost APFC Solution
- Support Single Windings Design
- PF>0.95 and THD<10% with Universal Input
- Fast Startup < 200ms
- $\pm 3\%$  CC Regulation
- Built-in HV MOSFET and Power Supply Circuit
- Quasi-Resonant for High Efficiency
- Very Low VDD Operation Current
- Excellent Line and Load Regulation
- Built-in Protections:
  - Output Over Voltage Protection (OVP)
  - Cycle-by-Cycle Current Limiting (OCP)
  - Leading Edge Blanking (LEB)
  - On-Chip Thermal Foldback (OTP)
- Available in SOP-7 Package

### APPLICATIONS

- High Power LED driver

### TYPICAL APPLICATION CIRCUIT

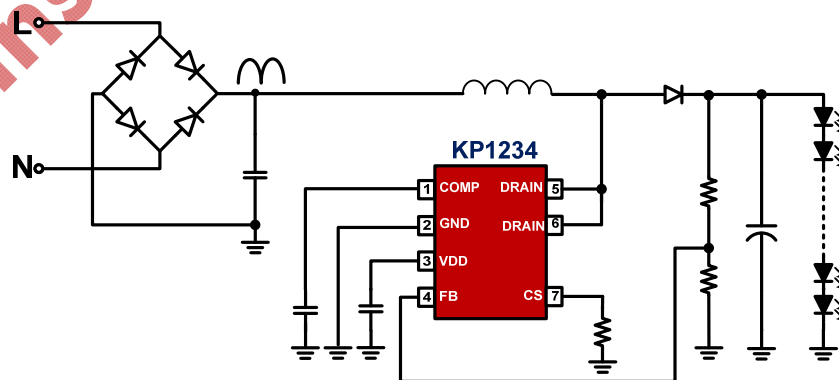

### GENERAL DESCRIPTION

KP1234 is a highly integrated LED Power Switch for LED lighting applications. The IC utilizes Quasi-Resonant (QR) Boost topology with active PFC control for high PF, low THD, and high efficiency.

KP1234 integrates with demagnetization signal detection technology, high voltage startup and IC power supply circuit, which eliminates auxiliary windings for demagnetization detection and power supply, simplifies system design and lower cost. The IC also integrates high precision current sampling technology, high precision output reference and Line voltage compensation for good output current regulation.

KP1234 integrates functions and protections of Under Voltage Lockout (UVLO), Cycle-by-cycle Current Limiting (OCP), Thermal Foldback (OTP), Output Over Voltage Protection (OVP), etc.