

## High Efficiency Non-isolated Buck LED Power Switch

### FEATURES

- Built-in HV Power Supply Circuit
- No VDD Capacitor Design
- Built-in CC Closed-loop Control
- $\pm 5\%$  CC Regulation
- Built-in AC Line and Load Compensation
- CCM Mode for Low Output Current Ripple
- Adjustable Output Current Ripple
- Built in protections:
  - Cycle-by-Cycle Current Limiting (OCP)
  - Leading Edge Blanking (LEB)
  - LED Load Hot-Plug Protection
  - LED Short Protection
  - On-Chip Thermal Foldback (OTP)
  - Hot Plug-in Protection
- Available in SOP-7 Package

### APPLICATIONS

- LED Bulb, LED Tube

### TYPICAL APPLICATION CIRCUIT

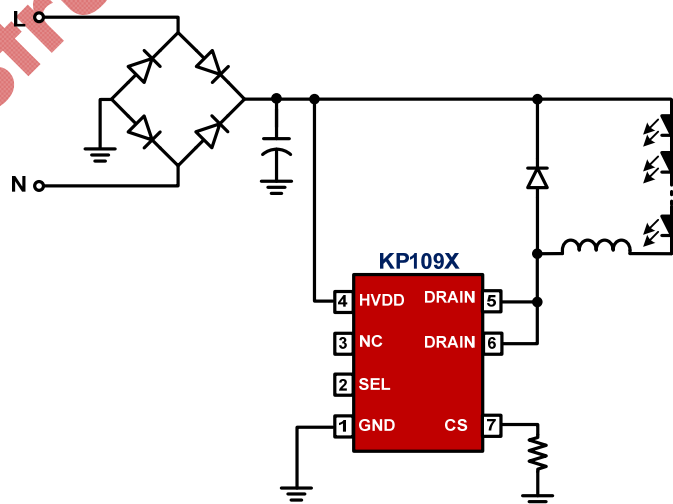

### GENERAL DESCRIPTION

KP109X is a highly integrated power switch for LED lighting applications, which adopts inductance current Continuous Conduction Mode (CCM) CC control to reduce output current ripple. The IC also integrates high precision inductance current sampling technology and high precision current reference for accurate output; additionally, line voltage compensation is integrated with for good constant current output regulation.

KP109X integrates HV power supply circuit and high precision CC closed-loop control without VDD Cap, loop compensation Cap and output capacitor, which greatly simplifies the system design.

KP109X integrates functions and protections of Under Voltage Lockout (UVLO), Cycle-by-cycle Current Limiting (OCP), Thermal Foldback (OTP), LED Short Protection, etc.