



TC7461 Dual Display Thermometer

General Description:

TC7461 is a high-performance Dual Display Thermometer CMOS IC. It will be used to measure Indoor and Outdoor Temperature, the temperature of environment can be measured from -50 (-58) to 70 (158), and it also can be set in or mode.

Features

- Range of Temperature : -50 (-58) 70 (158)
 If temperature > 70 (158), display H ()
 If temperature < -50 (-58), display L ()
- Number of channel : 2 channels , one for Indoor and one for Outdoor
- Battery operation : 1.3 V 1.65 V
- Resolution : 0.1° for the whole range -50 (-58) 70 (158)
- Accuracy : ±1 (±2)
- Sensor : 103AT-2B × 2 , will use a 3M wire for the outdoor sensor
- Oscillator : RC Oscillator only
- Sampling period : 10 sec approximate
- Change unit : NC - and Bond to VDD -
- LCD self -test : Power On full segment test 2 second
- LCD driver : 1/2 bias, 1/3 duty.
- Not-measuring current : Current is less than 15 uA

Block Diagram:

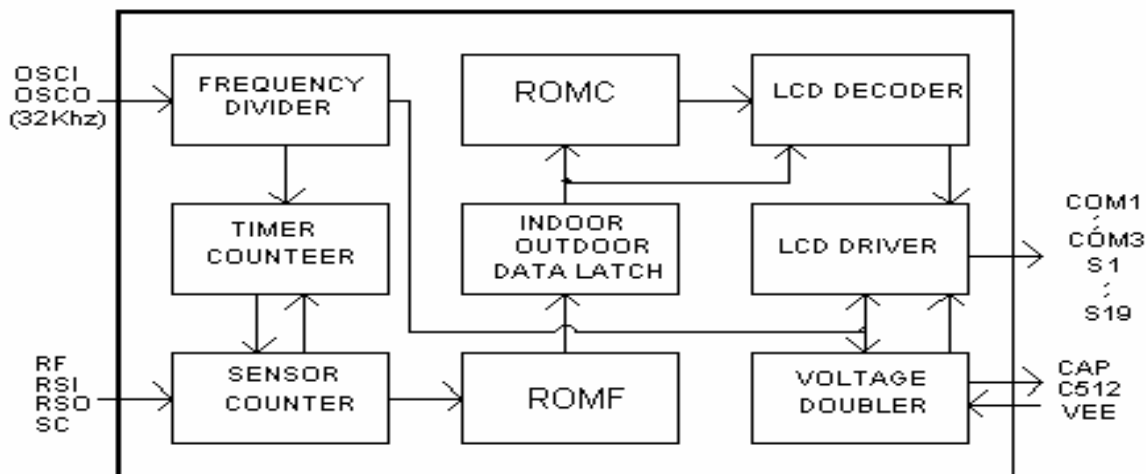

PAD DESCRIPTION:

Pad No.	Pad Name	I/O	DESCRIPTION
1	OSCI	I	Oscillator generator input pad.
2	OSCO	O	Oscillator generator output pad.
3	COM1	O	LCD common pad.
4	S1	O	LCD segment pad.
5	S2	O	LCD segment pad.
6	S3	O	LCD segment pad.
7	S4	O	LCD segment pad.
8	S5	O	LCD segment pad.
9	S6	O	LCD segment pad.
10	S7	O	LCD segment pad.
11	S8	O	LCD segment pad.
12	S9	O	LCD segment pad.
13	S10	O	LCD segment pad.
14	S11	O	LCD segment pad.
15	S12	O	LCD segment pad.
16	S13	O	LCD segment pad.
17	S14	O	LCD segment pad.
18	S15	O	LCD segment pad.
19	S16	O	LCD segment pad.
20	S17	O	LCD segment pad.
21	S18	O	LCD segment pad.
22	S19	O	LCD segment pad.
23	COM2	O	LCD common pad.
24	COM3	O	LCD common pad.
25	C512	O	Doubler voltage capacitor input pad.
26	CAP	I	Doubler voltage capacitor output pad.
27	VEE	O	Doubler voltage (3V) output pad.
28	VDD	I	IC Vdd pad.
29	TC	I	IC Test Pad
30	SFC	I	/ select pad, (bonding to Vss → ,bonding to Vdd→)
31	VSS	I	IC Vss pad.
32	SC	I	PAD 1 is sensor clock generator input pad.
33	RF	O	PAD 2 is reference resistor output pad.
34	RSI	O	PAD 3 is indoor sensor resistor output pad.
35	RSO	O	PAD 4 is outdoor sensor resistor output pad.
36	TA	I	IC test pad.inner pull low resistor.

ELECTRICAL DESCRIPTION:

ITEM	PARAMETER	TEST CONDITION	STAND VALUE			UNIT
			MIN.	TYP.	MAX.	
Vdd	Supply Voltage		1.30	1.5	1.65	V
VIL	Input Low Voltage	Vdd=1.5V		0	0.2	V
VIH	Input High Voltage	Vdd=1.5V	1.3	1.5		V
VOL	Output Low Voltage	Vdd=1.5V		0	0.1	V
VOH	Output High Voltage	Vdd=1.5V	1.4	1.5		V
Inm	Current No Measurement	Vdd=1.5V, LCD Display			15	uA
Irf	RF Pad Driving Current	Vdd=1.5V, Vds=-0.75V			-1	mA
Irsi	RSI Pad Driving Current	Vdd=1.5V, Vds=-0.75V			-1	mA
Irso	RSO Pad Driving Current	Vdd=1.5V, Vds=-0.75V			-1	mA

SFC PAD FUNCTION :

- If SFC is open , it display Temp in .
If SFC is switch to VDD , it displays Temp in .
- When the SFC state is changed no matter it is displaying the current Temp , the temperature will be converted and display in the corresponding scale (or) at a delay time less than 0.2 second.

TC7461 PAD'S DIAGRAM

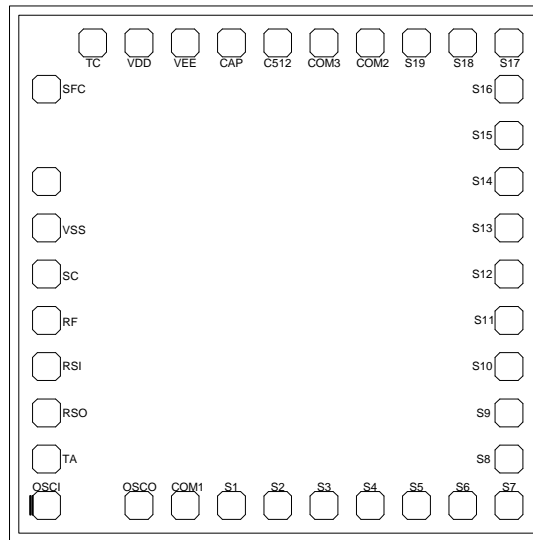

CHIP SIZE : X= 1610 um Y= 1730 um

PAD NAME	PAD No.	COORDINATE (X,Y)	PAD NAME	PAD No.	COORDINATE (X,Y)
OSCI	1	(-677.00, -712.00)	S16	19	(677.00, 562.00)
OSCO	2	(-387.00, -712.00)	S17	20	(677.00, 712.00)
COM1	3	(-257.00, -712.00)	S18	21	(527.00, 712.00)
S1	4	(-127.00, -712.00)	S19	22	(397.00, 712.00)
S2	5	(5.00, -712.00)	COM2	23	(267.00, 712.00)
S3	6	(137.00, -712.00)	COM3	24	(127.00, 712.00)
S4	7	(267.00, -712.00)	C512	25	(-5.00, 712.00)
S5	8	(397.00, -712.00)	CAP	26	(-137.00, 712.00)
S6	9	(527.00, -712.00)	VEE	27	(-267.00, 712.00)
S7	10	(677.00, -712.00)	VDD	28	(-397.00, 712.00)
S8	11	(677.00, -562.00)	TC	29	(-527.00, 712.00)
S9	12	(677.00, -422.00)	SFC	30	(-677.00, 562.00)
S10	13	(677.00, -282.00)	VSS	31	(-677.00, 142.00)
S11	14	(677.00, -142.00)	SC	32	(-677.00, 0.00)
S12	15	(677.00, 0.00)	RF	33	(-677.00, -142.00)
S13	16	(677.00, 142.00)	RSI	34	(-677.00, -282.00)
S14	17	(677.00, 282.00)	RSO	35	(-677.00, -422.00)
S15	18	(677.00, 422.00)	TA	36	(-677.00, -562.00)

NOTICE: On PCB, IC Substrate should not connect directly with VDD or Vss.

22 21 20 19 18 17 16 15 14 13 12 11 10 9 8 7 6 5 4 3 2 1

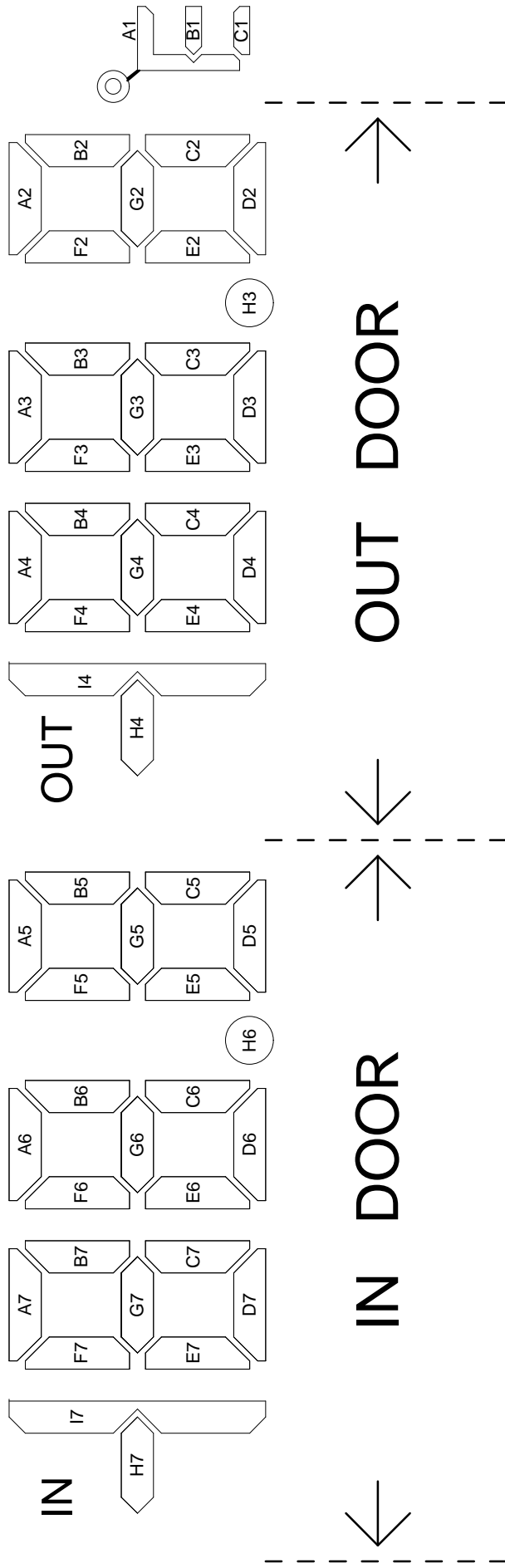

	S19	S18	S17	S16	S15	S14	S13	S12	S11	S10	S9	S8	S7	S6	S5	S4	S3	S2	S1
22	21	F7	A7	B7	F6	A6	B6	F5	A5	F4	A4	B4	F3	A3	B3	F2	A2	B2	A1
		COM2	E7	G7	E6	G6	E5	G5	E4	G4	E3	G3	E2	G2	E1	G1			COM1
COM3		I7	D7	H7	I4	D6	H6	I4	D5	H4	D4	H4	OUT	D3	H3				C1

SPEC : A. 1/3 DUTY , 1/2 BIAS. (LCD USES 3V)
 B. $V_{TH} = 1.5V$

TC7461 THERMOMETER APPLLLICATION

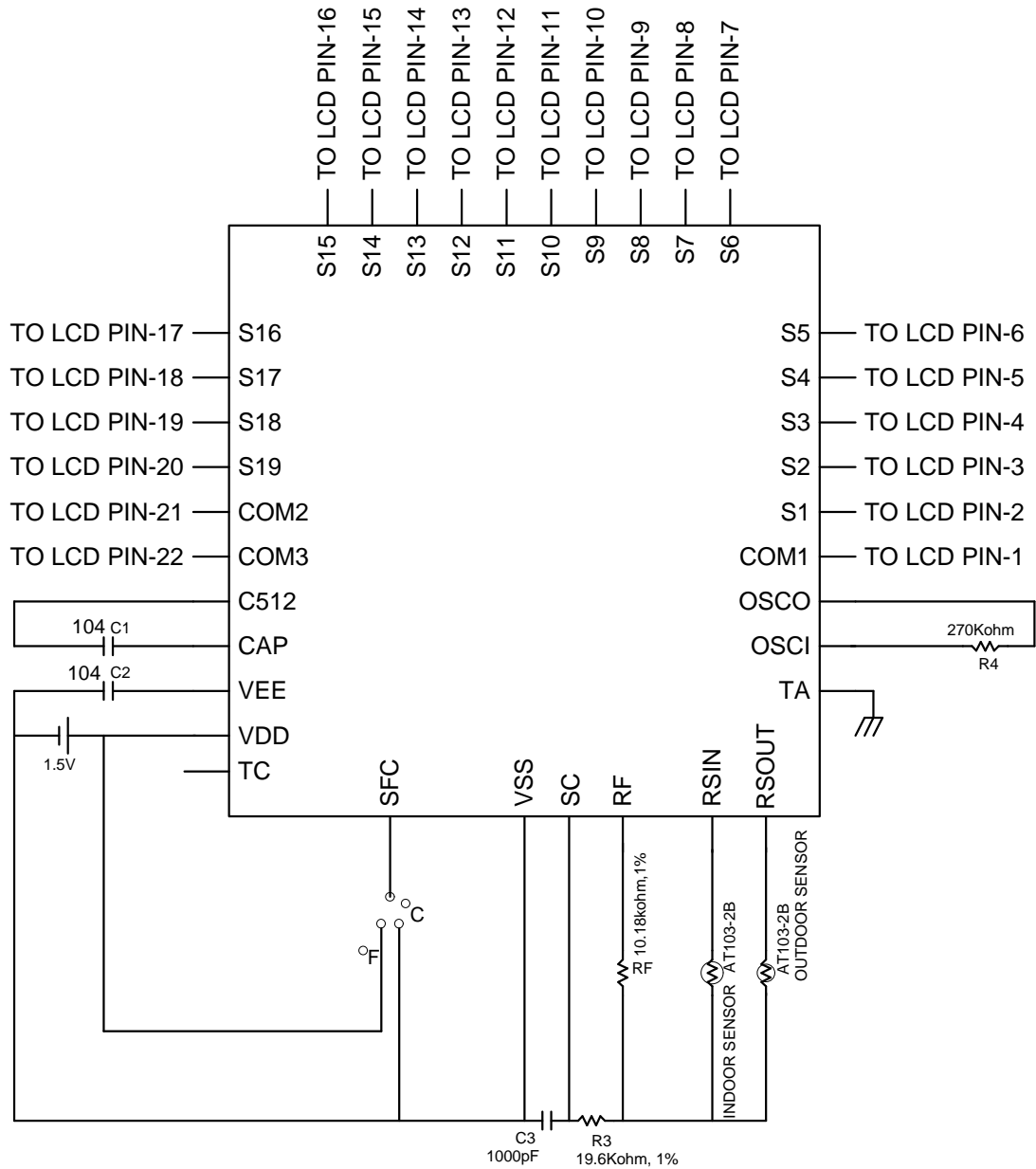

NOTES:

1. R4 use 270Kohm resistor.
2. RF use 10.18Kohm resistor.
3. indoor sensor use AT103-2B type sensor.
4. outdoor sensor use 3M wire AT103-2B type sensor, and this 3M wire C Equal is about 150pF.
5. RF is adjusted at 25° C temperature of environment.
6. If RF has been calibrated at 25° C, and check high temperature (about 65 to 68° C) , If temperature is more than 1° C ,and R3 will serial a 400ohm resistor. If temperature is less than 1° C ,and R3 will paralle a 1Mohm resistor.