

FEATURES

- ◆ Integrated LED current balance control circuit
- ◆ Wide input voltage range
- ◆ Drives up to 8 strings in parallel
- ◆ External PWM dimming control
- ◆ Time-shift PWM phase dimming control
- ◆ Multi-chip parallel operation for more than 8 LED strings
- ◆ MOSFET over-current protection
- ◆ LED short circuit protection
- ◆ LED open string protection
- ◆ Over-temperature protection
- ◆ Status output
- ◆ Low standby current

PIN DIAGRAM: 24 QFN

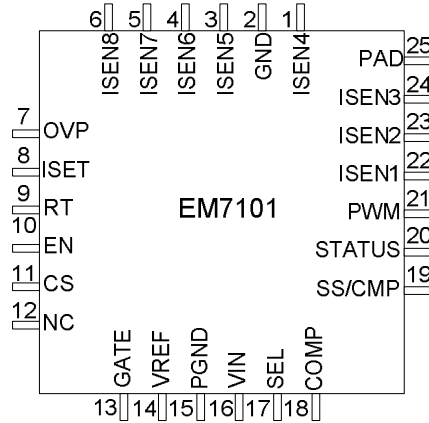

ORDERING INFORMATION

Part Number	Temp Range	Package
EM7101WB	-20°C to +85°C Note(2), Page 3	24 pin QFN Lead-Free
EM7101TE	-20°C to +85°C Note(2), Page 3	24-pin E-TSSOP Lead-Free
EM7101G	-20°C to +85°C Note(2), Page 3	24-pin SOP Lead-Free

GENERAL DESCRIPTION

EM7101 is a high efficiency DC-DC controller that drives up to eight strings.

EM7101 provides eight (8) LED current sense inputs and allows the backlight to remain functioning in the event that a string(s) is damaged during normal operation

The IC is able to balance the current flow for each LED string. It also consumes a low standby current for the backlight system.



PIN DESCRIPTION

Names	Pin No 24QFN	Pin No 24E-TSSOP	Pin No 24-SOP	I/O(1)	Description
ISEN4	1	5	5	I/O	LED Current Sense 4
GND	2	6	6	---	Signal Ground
ISEN5	3	10	15	I/O	LED Current Sense 5
ISEN6	4	7	8	I/O	LED Current Sense 6
ISEN7	5	8	9	I/O	LED Current Sense 7
ISEN8	6	9	7	I/O	LED Current Sense 8
OVP	7	11	10	I	Over-Voltage Protection
ISET	8	12	11	I/O	LED Current Resistor Setting
RT	9	13	12	I/O	Operation Frequency Resistor Setting
EN	10	14	13	I	Enable, on/ff control
CS	11	15	14	I/O	Power MOSFET Current Sense
NC	12	23	23	---	No connection
GATE	13	16	16	I/O	Low Side Power MOSFET Driver
VREF	14	17	17	I/O	5V Regulator Supply For Low Voltage Blocks
PGND	15	18	18	---	Power Ground
VIN	16	19	19	---	IC Power Supply
SEL	17	20	20	I	Selection Setting To Set 2, 3 or 4 LED Channels
COMP	18	21	21	I/O	Multi-Chip Parallel Operation
SS/CMP	19	22	22	I/O	Soft Start and Control Loop Compensation
STATUS	20	24	24	O	LED Operation Status Output
PWM	21	1	1	I	PWM Dimming Input
ISEN1	22	2	2	I/O	LED Current Sense 1
ISEN2	23	3	3	I/O	LED Current Sense 2
ISEN3	24	4	4	I/O	LED Current Sense 3

Note(1): I=Input, O=Output, I/O=Input/Output

ABSOLUTE MAXIMUM RATINGS

LED Operation Status Output	40.0V
GND,PGND	±0.3V
ISEN1/2/3/4/5/6/7/8, CS, EN	-0.3V to 40.0V
VREF, STATUS, OVP, PWM	-0.3V to 7.0V
ISET, SS/CMP, COMP, RT, SEL, GATE	-0.3V to(vref +0.3V)
Operating Frequency	200KHz to 2.5MHz
ISEN1-8 LED Current	80mA
Storage Temperature	-55°C to 150°C
Operating Junction Temperature	150°C

RECOMMENDED OPERATING RANGE

VIN – Input Voltage	4.5V-33V	
Maximum Operating Junction Temp.	125°C	
ISEN1/2/3/4/5/6/7/8, CS, EN	≤ 33V	
VREF, STATUS, OVP, PWM	0.0V to5.5V	
ISET, SS/CMP, COMP, RT, SEL,GATE	0.0V to VREF	
Operating Frequency	500kHz - 2MHz	
ISEN1-8 LED Current	10mA – 65mA	
PWM Frequency	100Hz – 20kHz	
RRT	21K ohm to 100K ohm	
Operating Temperature	-20°Cto+85°C	
Thermal Impedance ⁽²⁾	θ_{J-C}	θ_{J-A}
24 pin QFN ^(3,4)	5°C/W	38°C/W
24 pin E-TSSOP ^(5,6)	15°C/W	38°C/W
24 pin SOP	13°C/W	86°C/W

Note (2): Still air, low effective thermal conductivity board per JESD51-3.

Note (3): QFN bottom pad is recommended to be connected to ground.

Note (4): QFN θ_{J-A} under 50% and 0% bottom pad soldered condition is 43°C/W and 72°C/W respectively. The data was based on simulation results using a 4 Layer, 76.2 x 114.3 mm² Printed Circuit Board (PCB).

Note (5): E-TSSOP bottom pad is recommended to be connected to ground.

Note (6): E-TSSOP θ_{J-A} under 50% and 0% bottom pad soldered condition is 43°C/W and 72°C/W respectively. The data was based on simulation results using a 4 Layer, 76.2 x 114.3 mm² Printed Circuit Board (PCB).

ELECTRICAL CHARACTERISTICS

All specifications below are at $T_A=25^{\circ}\text{C}$, $V_{IN}=24\text{V}$; $R_{RT}=100\text{k}$ unless otherwise noted

PARAMETER	CONDITIONS	Limits			UNITS
		MIN	TYP	MAX	
VIN Operating Current	EN= PWM = 5V		10.2		MA
VIN Shutdown Current	EN= PWM= 0V		2.5	5	uA
VIN Stand-By Current	EN=5V, PWM=0V			150	uA
Enable					
EN and PWM Logic	High	2.45	-	-	
	Low		-	0.65	V
Under Voltage Lockout					
Lockout Threshold	$V_{REF_{Lockout}}$		3.6		V
Resume Threshold	$V_{REF_{Resume}}$		3.8		V
Reference					
Reference Voltage	V_{REF} , $V_{IN}>6\text{V}$		5.0		V
	Temperature Coefficient		100		ppm/ $^{\circ}\text{C}$
V_{REF} Output Current Capability	I_{VREF}			30	mA
Drive Logic					
GATE Sink Resistance	$V_{IN}>6\text{V}$		3.4		Ω
GATE Source Resistance	$V_{IN}>6\text{V}$		5		Ω
Minimum MOSFET ON Time			50		ns
Minimum MOSFET OFF Time			78		ns
Regulation					
Regulation LED Current per Channel	$I_{SET}=12\text{Kohm}$		50		mA
LED Current Balance Rate		-	-	± 1.5	%
Protection					
LED Open String Protection Threshold	OVP		2.0		V
Shutdown Under Abnormal Condition	OVP		3.0		V
LED Short Circuit Protection Threshold	$I_{SEN1}\sim 8$		3.5		V
Oscillator					
Operation Frequency	$R_{RT}=100\text{K}\Omega$		500		KHz
	Temperature Coefficient	-	80		ppm/ $^{\circ}\text{C}$

ELECTRICAL CHARACTERISTICS

All specifications below are at T=25°C, VIN=24V; R_{RT}=100kΩ unless otherwise noted

PARAMETER	CONDITIONS	Limits			UNITS
		MIN	TYP	MAX	
Status Output					
Sink Resistance	STATUS			100	Ohm
MOSFET Over-Current Protection					
NMOS Over-Current Protection	CS		0.52		V

PARAMETERS GUARANTEED BY DESIGN

PARAMETER	CONDITIONS	Limits			UNITS
		MIN	TYP	MAX	
VREF					
Load Regulation		-	5		mV / mA
Line Regulation		-	0.3		mV / V
Thermal Protection					
Lockout Temperature			145		°C
Resume Temperature			110		°C

FUNCTIONAL BLOCK DIAGRAM

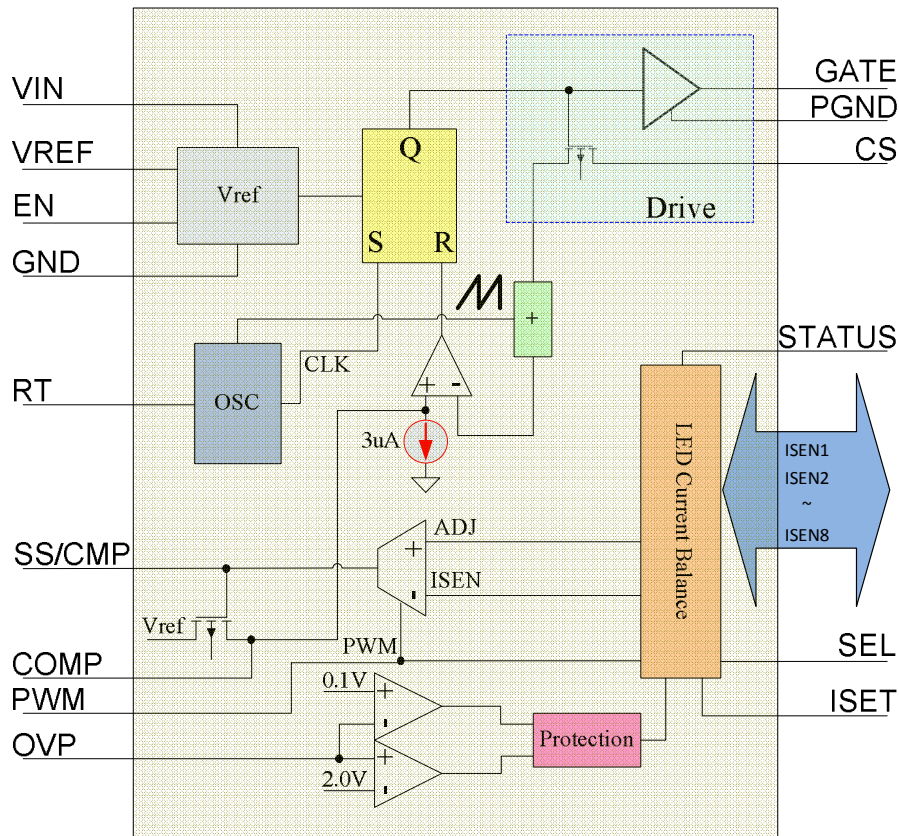

Figure 1

FUNCTIONAL DESCRIPTION

Enable

EM7101 is enabled if the voltage of the EN pin is greater than 2.4V. If the voltage of the EN pin is less than 0.7V, the IC will be disabled.

Under-voltage lockout

If the voltage of the VREF Pin drops to 3.6V, the IC output is disabled. When the voltage of the VREF pin increases to a 3.8V, the IC will work normally. The VREF has a max source capability of 30mA.

Oscillator

The operation frequency can be set by external resistor connected to RT. Resistor R_{RT} sets the charging current for the internal oscillator. The operating frequency can be calculated by the following equation.

$$f_{op} [\text{MHz}] = \frac{50}{R_{RT} [\text{k}]}$$

R_{RT} from 20K to 100K is suggested

LED String Selection`

To set the number of active strings:

- ISEN1~8 Active: Connect SEL to GND
- ISEN1~6 Active: Connect SEL to VREF
- ISEN1~4 Active: Connect SEL to NC

Setting LED Current

The LED current is determined by the following equation:

$$I_{LED} [\text{mA}] = \frac{600}{R_{SET} [\text{k}]}$$

This sensed LED current is for each string.

PWM Dimming

It can be set by applying a pulse width signal of 100Hz to 20kHz to PWM pin. The different duty cycle from 0% to 100% is able to control from minimum to maximum brightness.

In order to reduce ripple stresses, the EM7101 provides a time-shift PWM dimming.

If the voltage of the PWM pin is less than 0.7V for a period, the IC will be disabled and enter standby mode. If the voltage of the PWM pin is greater than 2.4V, the IC will work normally.

Multiple ICs Operation

If the application is more than 8 strings, several EM7101 ICs can be connected and use the same power. Refer to application circuit.

In this kind of application, the COMP pin for each IC must be shorted together. The N-MOSFET drive signal for this application is controlled by the Gate pin on the Master IC. The setting for the Slave IC(s) is almost the same as the Master IC, but we need to keep Gate pin floating and short CS pin to GND for Slave IC(s).

MOSFET OCP

EM7101 provides an over current protection by monitoring the N-MOSFET current. When the MOSFET turns on, the voltage at CS pin is going to rise up to 0.5V. At this time, the drive Gate will turn "off". Then, the drive Gate will turn "on" as soon as the next cycle begins.

LED Short Circuit Protection

When the voltage at any of the ISEN1-8 pins is over the threshold voltage of 3.5V during normal operation, the corresponding string is turned "off" and latched.

LED Open String Protection

If there is any LED string opened, V_o (output) will rise up until the voltage of the OVP pin reaches 2.0V. The IC will ignore the open string(s) and the rest string(s) will keep working normally.

If all of the LED strings are opened and the voltage of the OVP pin reaches 2.0V, the MOSFET drive (Gate pin) will turn off. The IC will shut down and keep latched.



Vo(Output) Short protection/ boost diode open Protection

If the voltage of the OVP pin is less than $\sim 0.1V$, the MOSFET drive(Gate pin) will turn off. This function is able to protect the converter from damage. The function will work if the boost diode is open or Vo(output) is shorted .

OTP

If IC temperature is higher than $140^{\circ}C$, the EM7101 will turn off . The IC will restart and work normally if the temperature falls below $110^{\circ}C$.

Shutdown Under Abnormal Condition

If the voltage of the OVP pin is greater than $3.0V$, the IC will shut down and latch. Toggle EN to restart the IC. This feature can be used for any other protection to shut down the IC by pulling up OVP pin above $3.0V$.

Status Output

If the IC works normally, the STATUS pin is active high(logic high). And the STATUS pin will become logic low if there is any of the following conditions happened:

- OVP
- OTP
- Any of LED strings is open
- LED short protection



REFERENCE APPLICATION CIRCUIT USING 24 PIN QFN

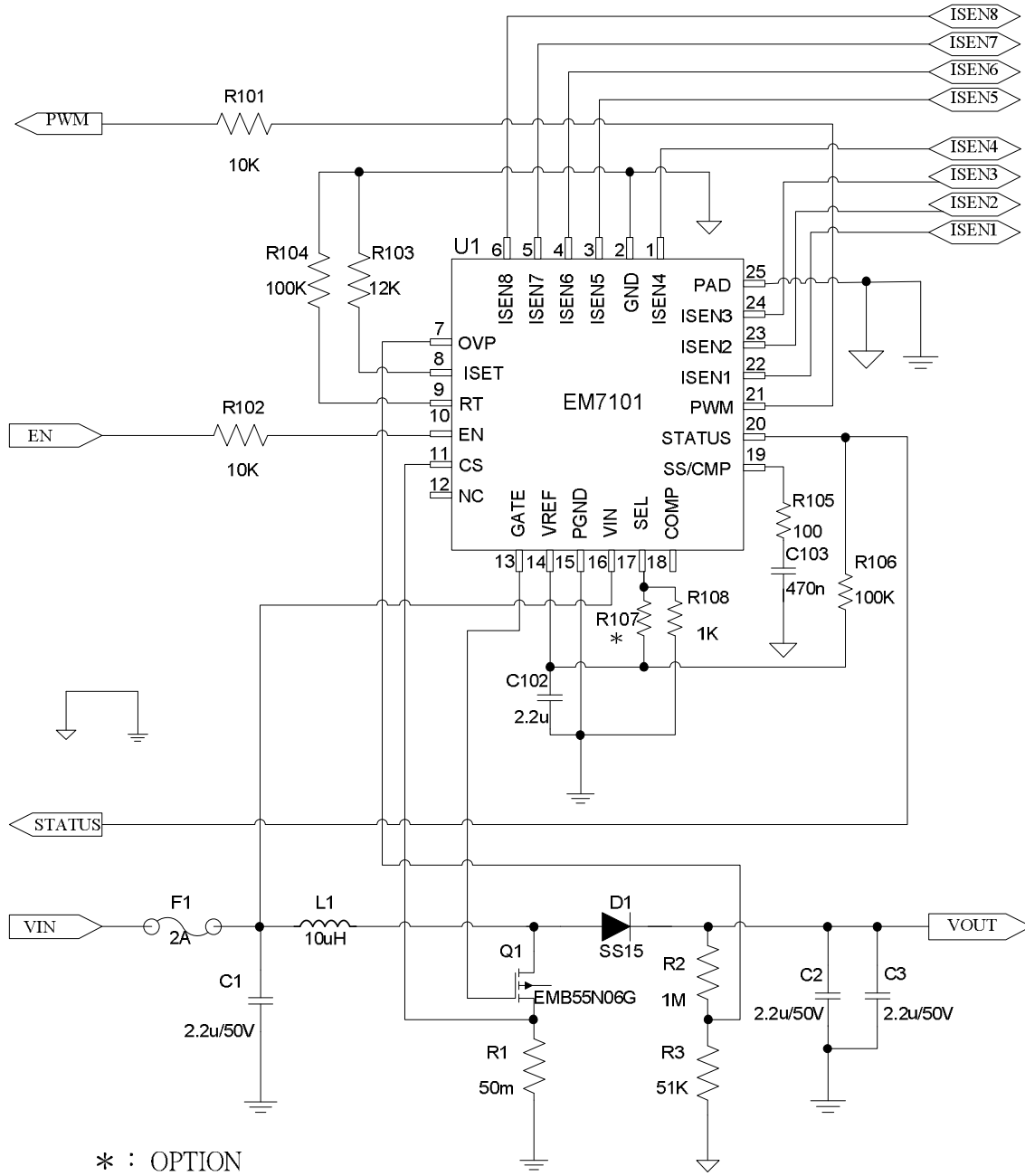

Figure 3: EM7101 application circuit

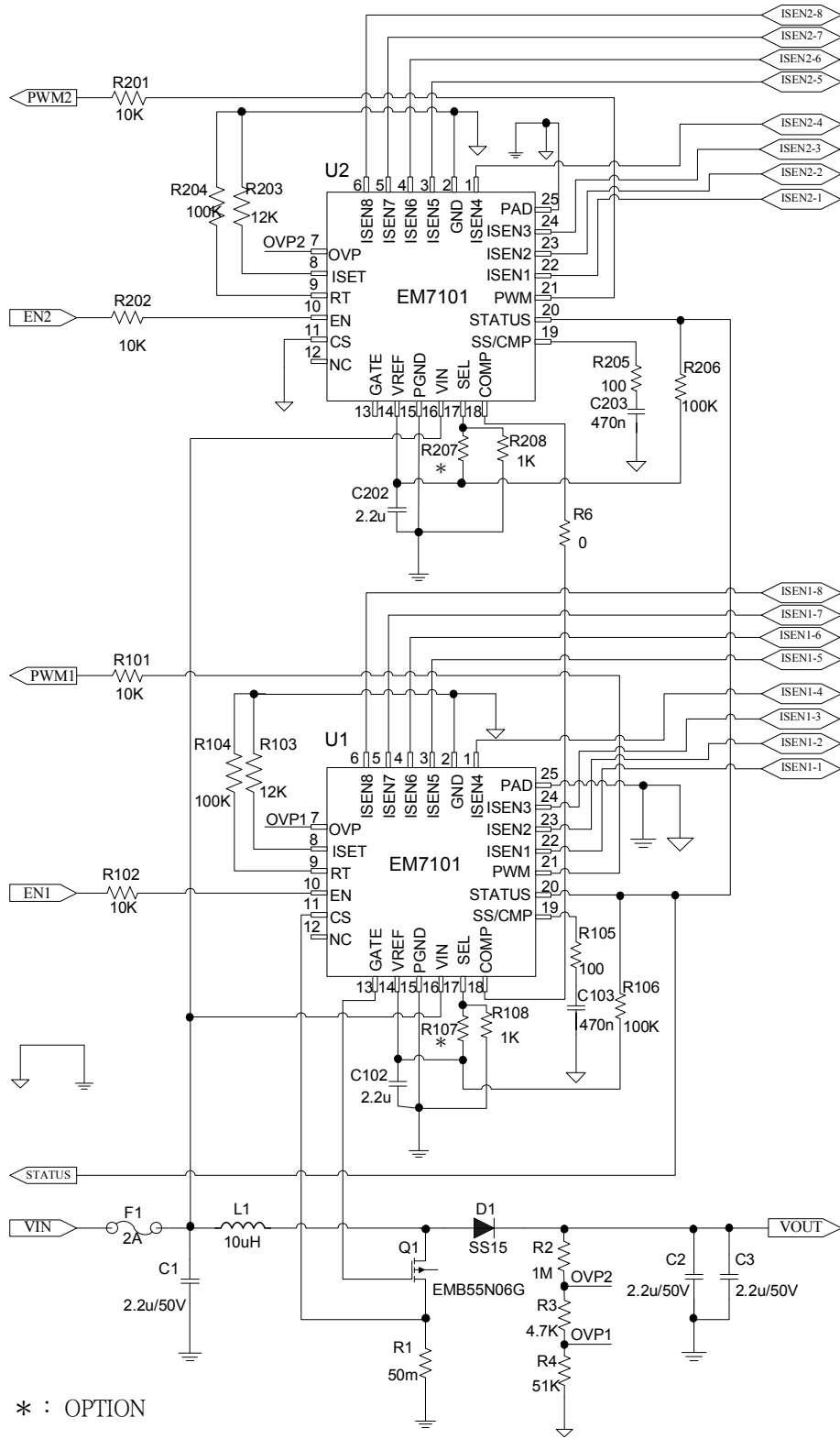
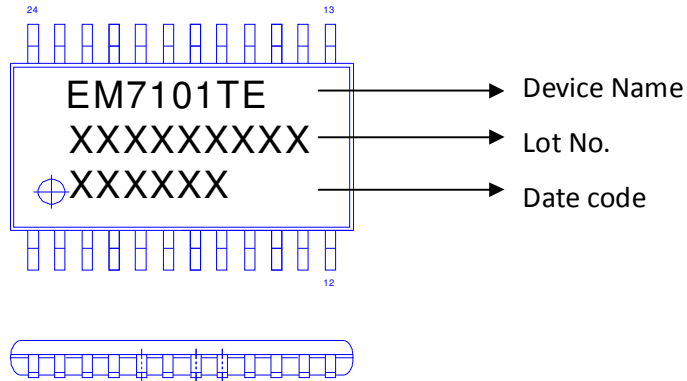
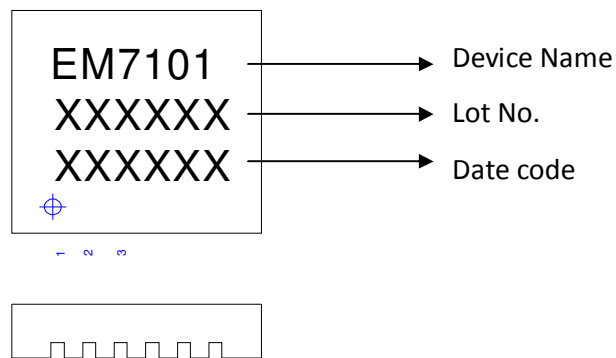

Figure 4: Application Circuit Using 2-EM7101 Driving 16LED Strings

Ordering & Marking Information:
 Device Name: EM7101TE for E-TSSOP-24



Device Name: EM7101 for QFN-24



Device Name: EM7101G for SOP-24

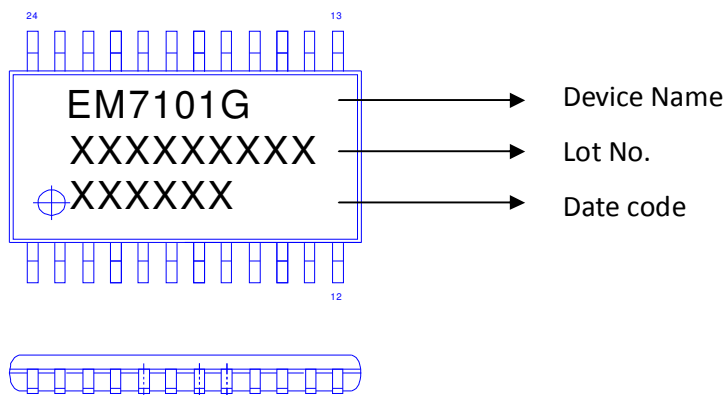



Outline Drawing
E-TSSOP-24

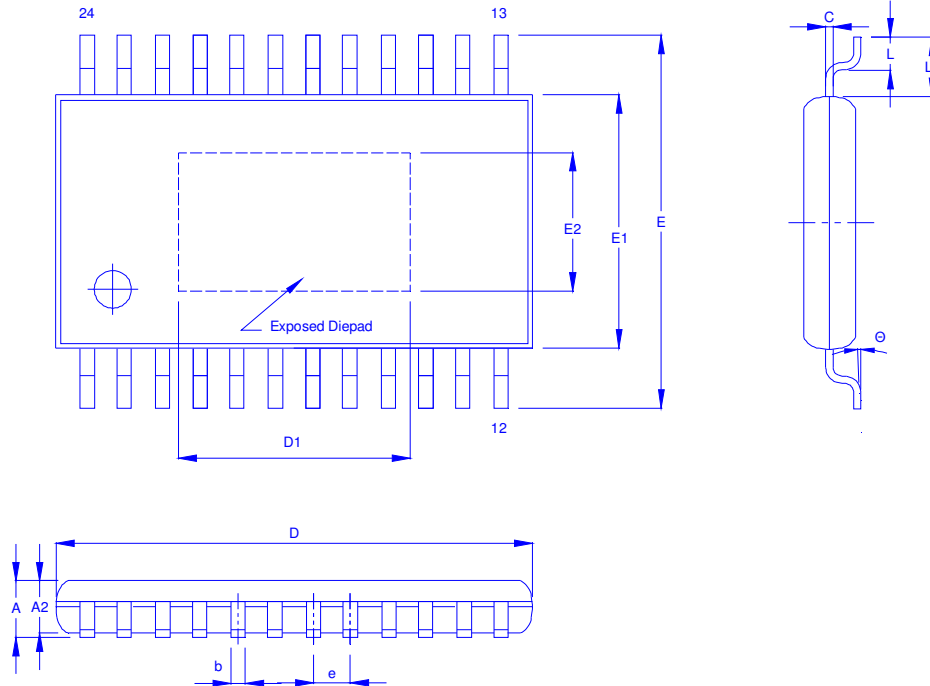

Dimension	A	A1	A2	b	c	D	D1	E	E1	E2	e	L	L1	θ			
Min.		0.00	0.8	0.19	0.127BSC	7.70	3.70	6.4BSC	4.30	2.28	0.65BSC	0.45	1.00REF	0°			
NOR			1.00			7.80				4.40					0.60		
Max.	1.2	0.15	1.05	0.30			7.90		4.62			4.50		2.85		0.75	



Outline Drawing
QFN-24

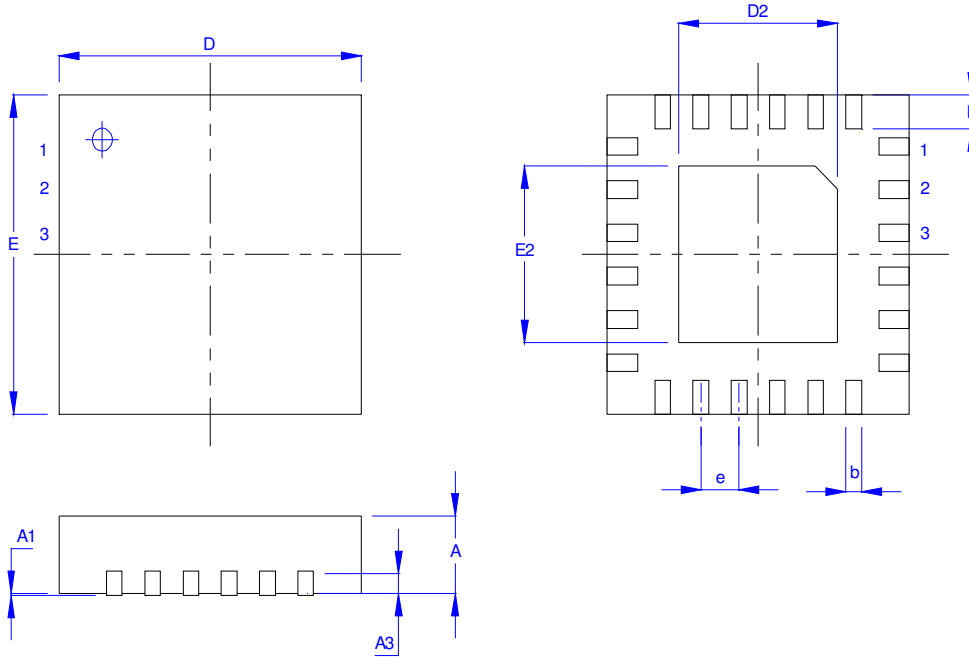

Dimension	A	A1	A3	b	D	D2	E	E2	e	L
Min.	0.70	0	0.203REF	0.18	3.90	1.90	3.90	1.90	0.50BSC	0.30
NOM.	0.75	0.02		0.25	4.0	2.00	4.00	2.00		0.40
Max.	0.80	0.05		0.30	4.10	2.10	4.10	2.10		0.50



Outline Drawing
SOP-24

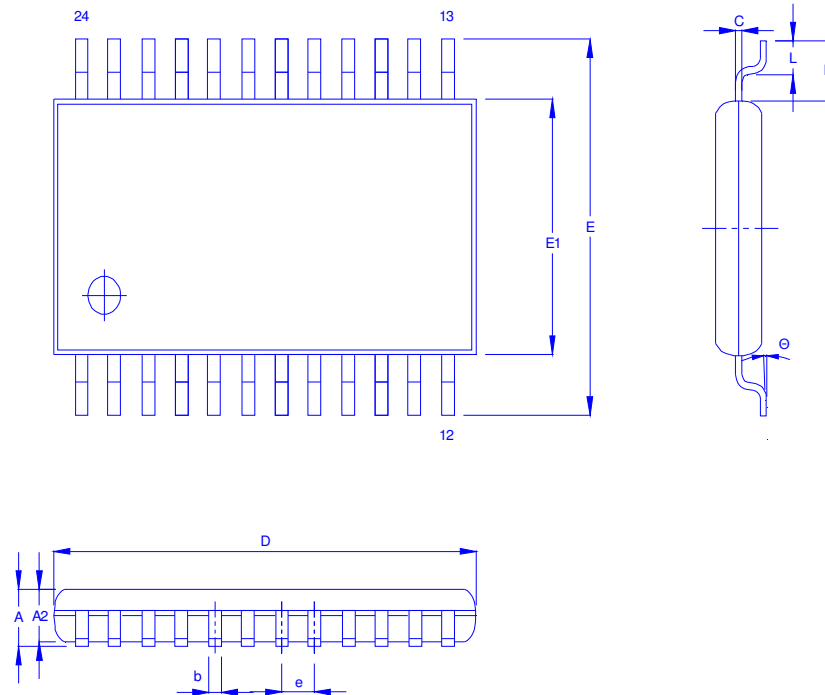

Dimension	A	A1	A2	b	c	D	E	E1	e	L	L1	H	θ
Min.	2.36	0.1	2.26	0.35	0.23	15.4	10.00	7.4	1.27	0.51	1.4	0.25	0°
NOR	2.54	0.2	-	-	-		10.31	7.5		-		-	
Max.	2.64	0.3	-	0.48	0.31		10.65	7.6		1.02		0.75	8°