

N-Channel Logic Level Enhancement Mode Field Effect Transistor

Product Summary:

$BV_{DSS}$	200V
$R_{DS(on) (MAX.)}$	$0.5 \Omega$
$I_D$	1.6A

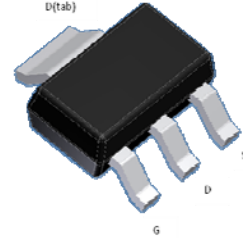
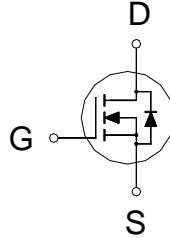

UIS, 100% Tested

Pb-Free Lead Plating & Halogen Free



ABSOLUTE MAXIMUM RATINGS ( $T_C = 25^\circ\text{C}$  Unless Otherwise Noted)

PARAMETERS/TEST CONDITIONS		SYMBOL	LIMITS	UNIT
Gate-Source Voltage		$V_{GS}$	$\pm 30$	V
Continuous Drain Current	$T_C = 25^\circ\text{C}$	$I_D$	1.6	A
	$T_C = 100^\circ\text{C}$		1	
Pulsed Drain Current <sup>1</sup>		$I_{DM}$	6.4	
Power Dissipation	$T_C = 25^\circ\text{C}$	$P_D$	6.25	W
	$T_C = 100^\circ\text{C}$		2.5	
Operating Junction & Storage Temperature Range		$T_{j}, T_{stg}$	-55 to 150	$^\circ\text{C}$

THERMAL RESISTANCE RATINGS

THERMAL RESISTANCE	SYMBOL	TYPICAL	MAXIMUM	UNIT
Junction-to-Case	$R_{\theta JC}$		20	$^\circ\text{C} / \text{W}$
Junction-to-Ambient	$R_{\theta JA}$		150	

<sup>1</sup>Pulse width limited by maximum junction temperature.

<sup>2</sup>Duty cycle  $\leq 1\%$



**ELECTRICAL CHARACTERISTICS ( $T_c = 25\text{ }^\circ\text{C}$ , Unless Otherwise Noted)**

PARAMETER	SYMBOL	TEST CONDITIONS	LIMITS			UNIT
			MIN	TYP	MAX	
<b>STATIC</b>						
Drain-Source Breakdown Voltage	$V_{(BR)DSS}$	$V_{GS} = 0V, I_D = 250\mu A$	200			V
Gate Threshold Voltage	$V_{GS(th)}$	$V_{DS} = V_{GS}, I_D = 250\mu A$	3.0	4.0	5.0	
Gate-Body Leakage	$I_{GSS}$	$V_{DS} = 0V, V_{GS} = \pm 30V$			$\pm 100$	nA
Zero Gate Voltage Drain Current	$I_{DSS}$	$V_{DS} = 160V, V_{GS} = 0V$			1	$\mu A$
		$V_{DS} = 130V, V_{GS} = 0V, T_J = 125\text{ }^\circ\text{C}$			25	
On-State Drain Current <sup>1</sup>	$I_{D(ON)}$	$V_{DS} = 5V, V_{GS} = 10V$	1.6			A
Drain-Source On-State Resistance <sup>1</sup>	$R_{DS(ON)}$	$V_{GS} = 10V, I_D = 0.8A$		0.4	0.5	$\Omega$
Forward Transconductance <sup>1</sup>	$g_{fs}$	$V_{DS} = 5V, I_D = 0.8A$		2		S
<b>DYNAMIC</b>						
Input Capacitance	$C_{iss}$	$V_{GS} = 0V, V_{DS} = 25V, f = 1MHz$		803		pF
Output Capacitance	$C_{oss}$			19		
Reverse Transfer Capacitance	$C_{rss}$			16		
Total Gate Charge <sup>1,2</sup>	$Q_g$	$V_{DS} = 100V, V_{GS} = 10V, I_D = 0.8A$		21.3		nC
Gate-Source Charge <sup>1,2</sup>	$Q_{gs}$			2.9		
Gate-Drain Charge <sup>1,2</sup>	$Q_{gd}$			6		
Turn-On Delay Time <sup>1,2</sup>	$t_{d(on)}$	$V_{DS} = 100V, I_D = 0.5A, V_{GS} = 10V, R_{GS} = 6\Omega$		20		nS
Rise Time <sup>1,2</sup>	$t_r$			60		
Turn-Off Delay Time <sup>1,2</sup>	$t_{d(off)}$			20		
Fall Time <sup>1,2</sup>	$t_f$			50		
<b>SOURCE-DRAIN DIODE RATINGS AND CHARACTERISTICS (<math>T_c = 25\text{ }^\circ\text{C}</math>)</b>						
Continuous Current	$I_S$				1.6	A
Pulsed Current <sup>3</sup>	$I_{SM}$				6.4	
Forward Voltage <sup>1</sup>	$V_{SD}$	$I_F = I_S, V_{GS} = 0V$			1.5	V

<sup>1</sup>Pulse test : Pulse Width  $\leq 300\ \mu\text{sec}$ , Duty Cycle  $\leq 2\%$ .

<sup>2</sup>Independent of operating temperature.

<sup>3</sup>Pulse width limited by maximum junction temperature.

Ordering & Marking Information:

Device Name: EMDE0N20Q for SOT-223

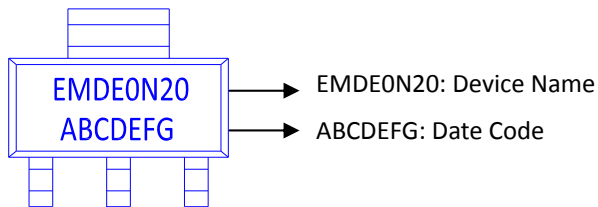

Outline Drawing

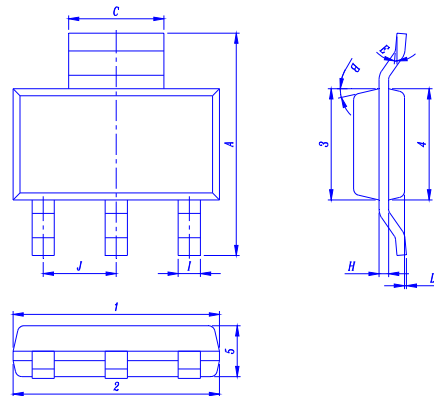

Dimension in mm

Dimension	A	C	D	E	I	H	B	J	1	2	3	4	5
Min.	6.70	2.90	0.02	0°	0.60	0.25			6.30	63.0	3.30	3.30	1.40
Typ.							13°	2.30					
Max.	7.30	3.10	0.10	10°	0.80	0.35			6.70	6.70	3.70	3.70	1.80

Recommended minimum pads

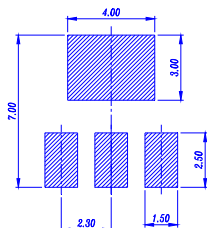



TYPICAL CHARACTERISTICS

