

N-Channel Logic Level Enhancement Mode Field Effect Transistor

Product Summary:

| | |
|---------------------|--------------|
| BV_{DSS} | 200V |
| $R_{DS(on) (MAX.)}$ | 0.5Ω |
| I_D | 7A |

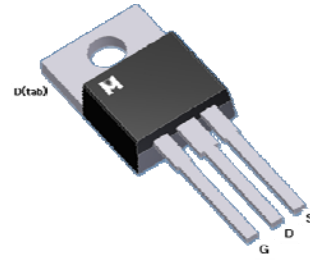
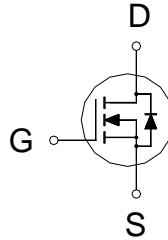

UIS, Rg 100% Tested

Pb-Free Lead Plating



ABSOLUTE MAXIMUM RATINGS ($T_C = 25^\circ C$ Unless Otherwise Noted)

| PARAMETERS/TEST CONDITIONS | | SYMBOL | LIMITS | UNIT |
|--|--|------------------|------------|------------|
| Gate-Source Voltage | | V_{GS} | ± 30 | V |
| Continuous Drain Current | $T_C = 25^\circ C$ | I_D | 7 | A |
| | $T_C = 100^\circ C$ | | 5 | |
| Pulsed Drain Current ¹ | | I_{DM} | 28 | |
| Avalanche Current | | I_{AS} | 1.5 | |
| Avalanche Energy | $L = 1mH, I_D = 1.5A, R_G = 25 \Omega$ | E_{AS} | 1.12 | mJ |
| Repetitive Avalanche Energy ² | $L = 0.5mH$ | E_{AR} | 0.56 | |
| Power Dissipation | $T_C = 25^\circ C$ | P_D | 50 | W |
| | $T_C = 100^\circ C$ | | 20 | |
| Operating Junction & Storage Temperature Range | | T_{j}, T_{stg} | -55 to 150 | $^\circ C$ |

THERMAL RESISTANCE RATINGS

| THERMAL RESISTANCE | SYMBOL | TYPICAL | MAXIMUM | UNIT |
|---------------------|-----------------|---------|---------|----------------|
| Junction-to-Case | $R_{\theta JC}$ | | 2.5 | $^\circ C / W$ |
| Junction-to-Ambient | $R_{\theta JA}$ | | 62.5 | |

¹Pulse width limited by maximum junction temperature.

²Duty cycle $\leq 1\%$



ELECTRICAL CHARACTERISTICS ($T_c = 25\text{ }^\circ\text{C}$, Unless Otherwise Noted)

| PARAMETER | SYMBOL | TEST CONDITIONS | LIMITS | | | UNIT |
|---|---------------|---|--------|------|-----------|----------|
| | | | MIN | TYP | MAX | |
| STATIC | | | | | | |
| Drain-Source Breakdown Voltage | $V_{(BR)DSS}$ | $V_{GS} = 0V, I_D = 250\mu A$ | 200 | | | V |
| Gate Threshold Voltage | $V_{GS(th)}$ | $V_{DS} = V_{GS}, I_D = 250\mu A$ | 3.0 | 4.0 | 5.0 | |
| Gate-Body Leakage | I_{GSS} | $V_{DS} = 0V, V_{GS} = \pm 30V$ | | | ± 100 | nA |
| Zero Gate Voltage Drain Current | I_{DSS} | $V_{DS} = 160V, V_{GS} = 0V$ | | | 1 | μA |
| | | $V_{DS} = 130V, V_{GS} = 0V, T_J = 125\text{ }^\circ\text{C}$ | | | 25 | |
| On-State Drain Current ¹ | $I_{D(ON)}$ | $V_{DS} = 10V, V_{GS} = 10V$ | 7 | | | A |
| Drain-Source On-State Resistance ¹ | $R_{DS(ON)}$ | $V_{GS} = 10V, I_D = 3.5A$ | | 0.4 | 0.5 | Ω |
| Forward Transconductance ¹ | g_{fs} | $V_{DS} = 5V, I_D = 3.5A$ | | 2 | | S |
| DYNAMIC | | | | | | |
| Input Capacitance | C_{iss} | $V_{GS} = 0V, V_{DS} = 25V, f = 1MHz$ | | 803 | | pF |
| Output Capacitance | C_{oss} | | | 19 | | |
| Reverse Transfer Capacitance | C_{rss} | | | 16 | | |
| Gate Resistance | R_g | $V_{GS} = 15mV, V_{DS} = 0V, f = 1MHz$ | | 2.0 | | Ω |
| Total Gate Charge ^{1,2} | Q_g | $V_{DS} = 100V, V_{GS} = 10V, I_D = 3.5A$ | | 21.3 | | nC |
| Gate-Source Charge ^{1,2} | Q_{gs} | | | 2.9 | | |
| Gate-Drain Charge ^{1,2} | Q_{gd} | | | 6 | | |
| Turn-On Delay Time ^{1,2} | $t_{d(on)}$ | $V_{DS} = 100V, I_D = 1A, V_{GS} = 10V, R_{GS} = 6\Omega$ | | 20 | | nS |
| Rise Time ^{1,2} | t_r | | | 60 | | |
| Turn-Off Delay Time ^{1,2} | $t_{d(off)}$ | | | 20 | | |
| Fall Time ^{1,2} | t_f | | | 50 | | |
| SOURCE-DRAIN DIODE RATINGS AND CHARACTERISTICS ($T_c = 25\text{ }^\circ\text{C}$) | | | | | | |
| Continuous Current | I_S | | | | 7 | A |
| Pulsed Current ³ | I_{SM} | | | | 28 | |
| Forward Voltage ¹ | V_{SD} | $I_F = I_S, V_{GS} = 0V$ | | | 1.5 | V |
| Reverse Recovery Time | t_{rr} | $I_F = 7A, dI_F/dt = 100A / \mu S$ | | 1450 | | nS |
| Reverse Recovery Charge | Q_{rr} | | | 0.85 | | μC |

¹Pulse test : Pulse Width $\leq 300\ \mu\text{sec}$, Duty Cycle $\leq 2\%$

²Independent of operating temperature.

³Pulse width limited by maximum junction temperature.

Ordering & Marking Information:

Device Name: EMDE0N20E for TO-220

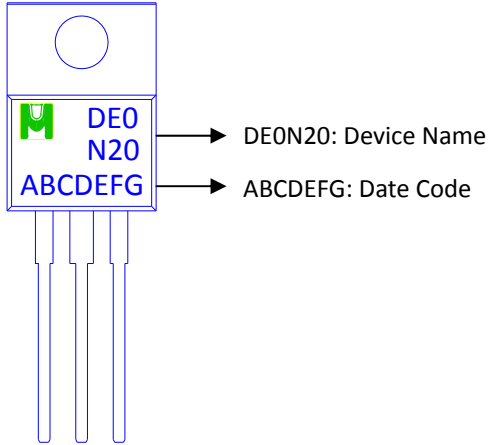



TYPICAL CHARACTERISTICS

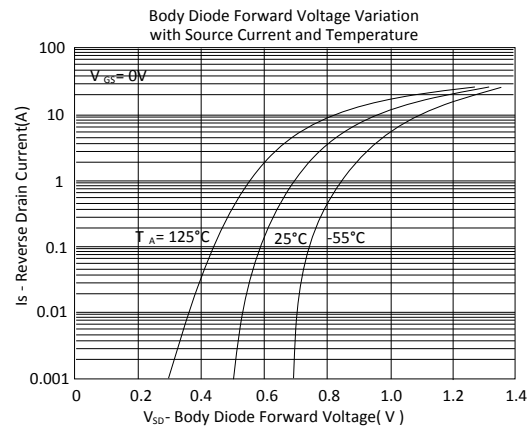
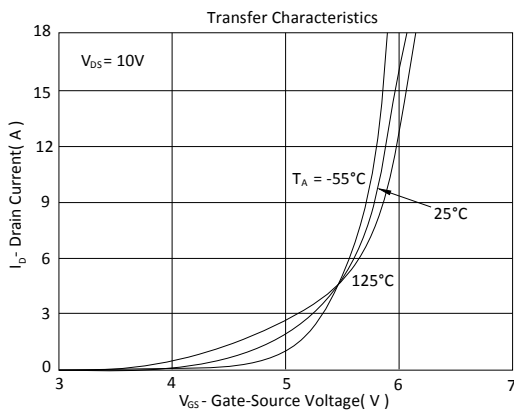
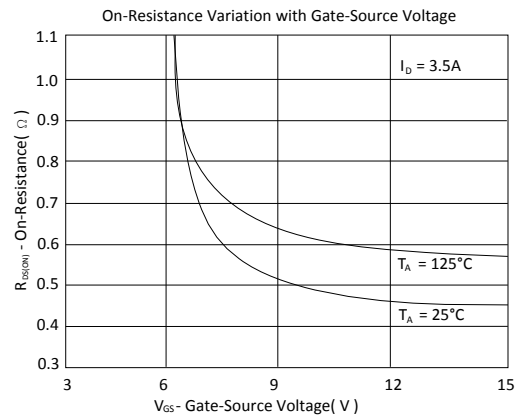
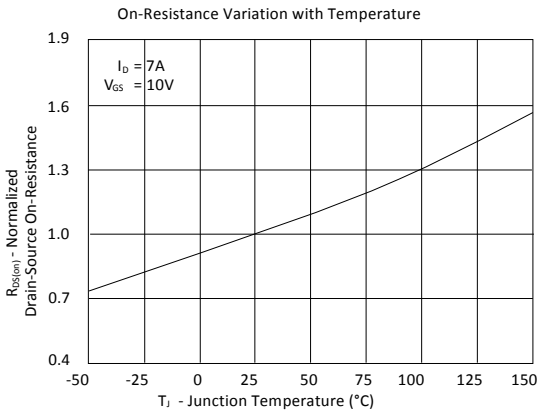
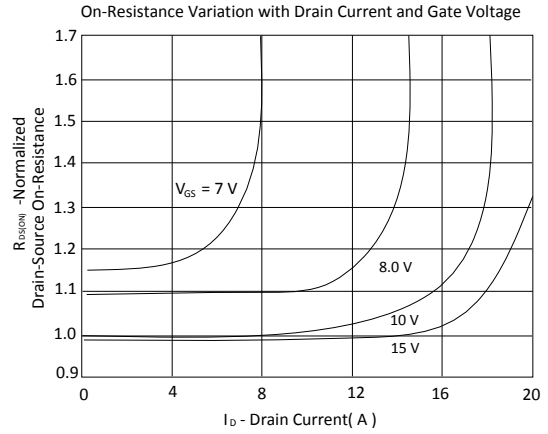
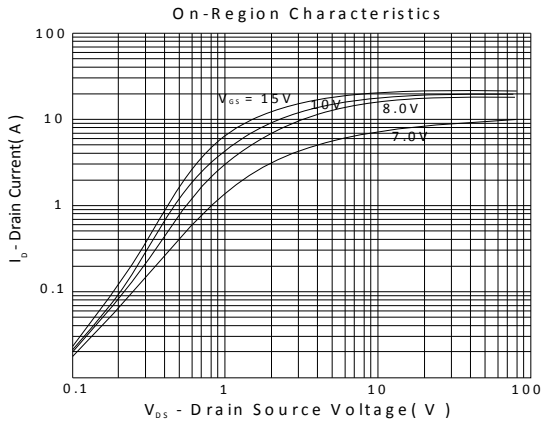

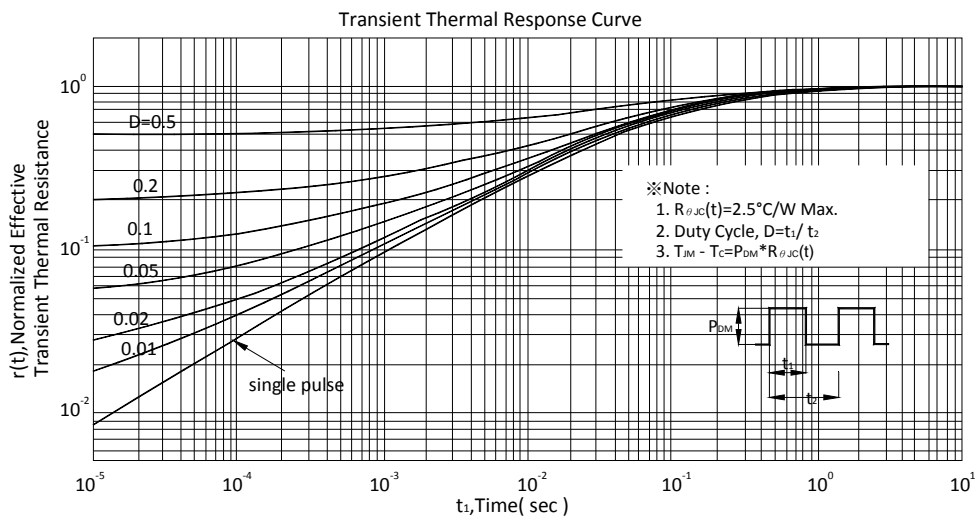
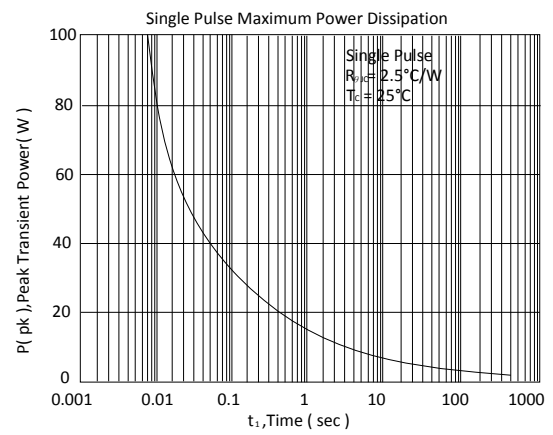
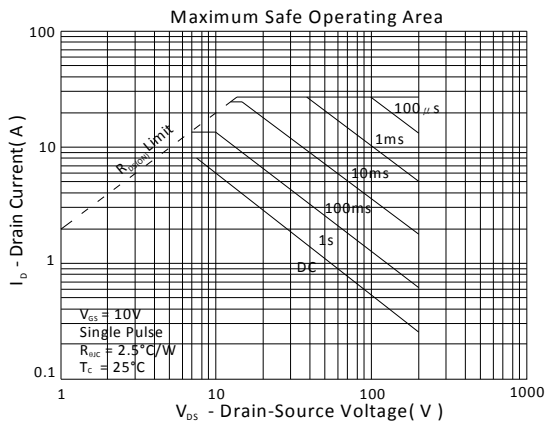
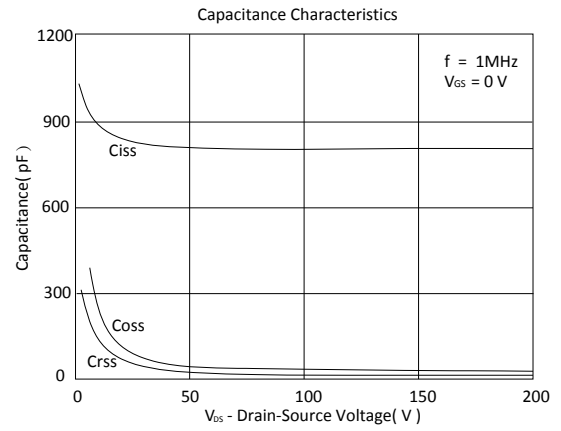
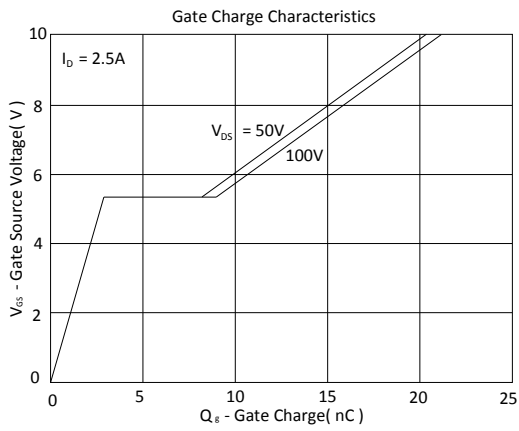

Outline Drawing

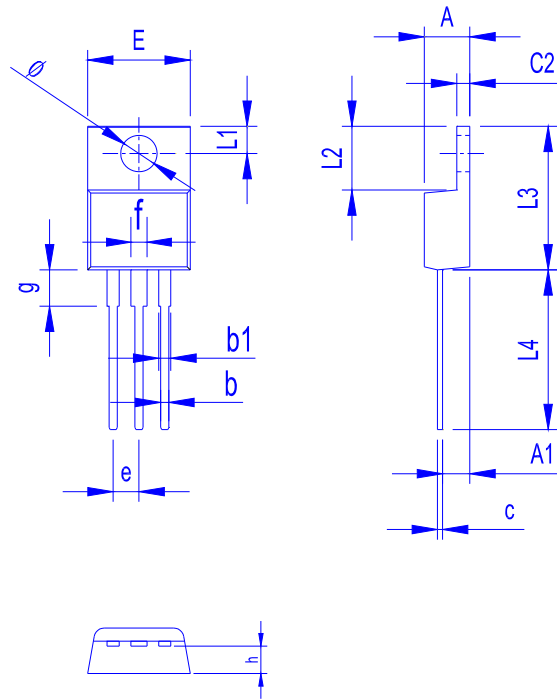

Dimension in mm

| Dimension | A | b | b1 | c | c2 | E | L1 | L2 | L3 | L4 | ø | e | f | g | h |
|-----------|------|------|------|------|------|-------|------|------|-------|-------|------|------|------|------|------|
| Min. | 4.20 | 0.70 | 0.90 | 0.30 | 1.10 | 9.80 | 2.55 | 6.10 | 14.80 | 13.50 | 3.40 | 2.35 | 1.30 | 3.40 | 2.40 |
| Max. | 4.80 | 1.10 | 1.50 | 0.70 | 1.50 | 10.50 | 2.85 | 6.50 | 15.40 | 14.50 | 3.80 | 2.75 | 1.90 | 3.80 | 3.00 |