



1.5A Power Distribution Switch

General Description

The EM5213 is an N-channel MOSFET high-side power switch without parasitic body diode between drain and source. The EM5213 provides very low on-resistance as 38mΩ. The fault flag output function indicates fault conditions to the local USB controller. The other features include soft start, current limit protection, Power-On-Reset function, and over temperature protection. The EM5213 is available in SOT23-5 package.

Ordering Information

Part Number	Package	Remark
EM5213AJ-10A	SOT23-5	Active High
EM5213J-10A	SOT23-5	Active Low
EM5213AJ-15A	SOT23-5	Active High
EM5213J-15A	SOT23-5	Active Low

Features

- Wide Input Range 2.7V to 5.5V
- Low MOSFET On Resistance(38mΩ)
- 2us Short Protection Response
- Low Quiescent(65uA) & Shutdown Current
- Deglitched Open-Drain Fault Flag Output
- Reverse Current Flow blocking
- Power On Reset Function
- Current Limit Protection
- Over Temperature Protection
- Soft Start and Fast turn off
- Reverse Voltage Protection
- Enable Active High or Active Low
- UL Recognized

Applications

- USB
- Notebook & Netbook & MB

Pin Configuration

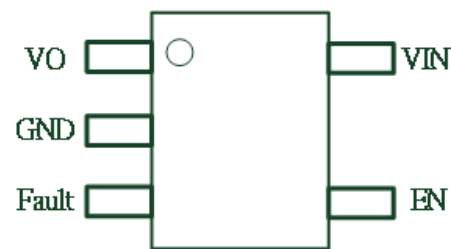

SOT23-5

Typical Application Circuit

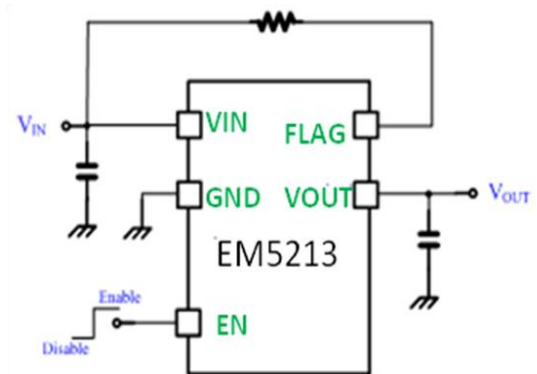

Note: A low ESR >1uF capacitor between VOUT & VIN to GND is recommended.

Pin Assignment

Pin Name	Pin No. SOT	Pin Function
GND	2	Ground.
VIN	5	Input Voltage. This is the drain input to the power device that supplies current to the output pin. Minimum 1uF low ESR ceramic capacitor is recommended at this pin.
EN / EN#	4	Chip Enable Input (Active high for EN, Active low for EN#)
FLAG (Fault)	3	Fault Flag Output. This is an open-drain output and is set low impedance once current limit or over temperature protection enabled.
VOUT	1	Output Voltage. VOUT is power output pin.

Function Block Diagram

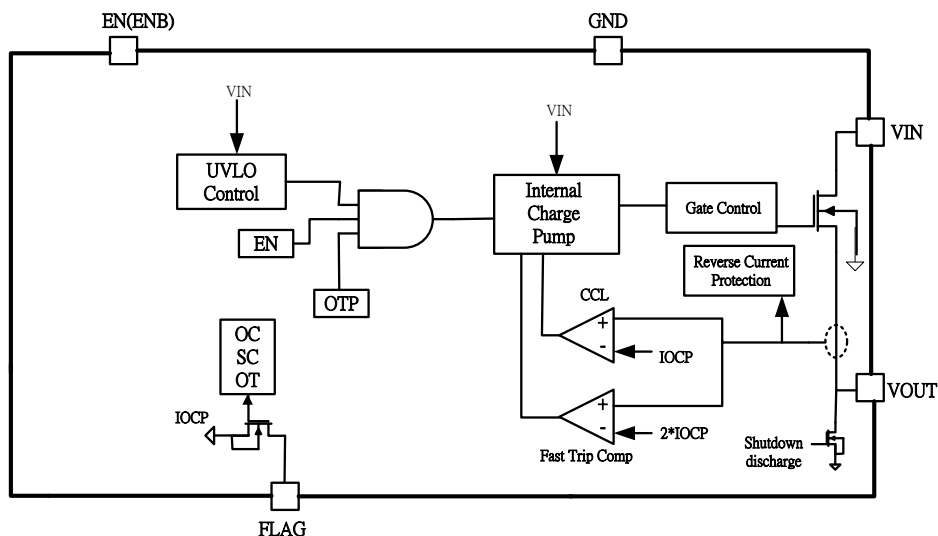

Absolute Maximum Ratings (Note1)

- V_{IN} ----- -0.3V to +6.0V
- Other Pins----- -0.3V to ($V_{IN}+0.3V$)
- Power Dissipation, P_D @ $T_A = 25^{\circ}C$, EM5213-10/15A ----- 0.8 W
- Package Thermal Resistance, θ_{JA} , EM5213-10/15A (Note 2) ----- $100^{\circ}C/W$
- Junction Temperature----- $150^{\circ}C$
- Lead Temperature (Soldering, 10 sec.)----- $260^{\circ}C$
- Storage Temperature ----- $-65^{\circ}C$ to $150^{\circ}C$
- ESD susceptibility (Note3)
 - HBM (Human Body Mode)----- 2KV
 - MM (Machine Mode)----- 200V
 - CDM (Charged Device Mode) ----- 1KV

Recommended Operating Conditions (Note4)

- Supply Input Voltage, V_{IN} ----- +2.7V to +5.5V
- Junction Temperature ----- -40°C to 125°C
- Ambient Temperature ----- -40°C to 85°C

Electrical Characteristics
 $V_{IN}=5V, T_A=25^{\circ}C$, unless otherwise specified

Parameter	Symbol	Test Conditions	Min	Typ	Max	Units
Supply Input Section						
POR Threshold	V_{PORTH}		-	2.2	2.5	V
Quiescent Current	I_Q	$I_{OUT}=0A$	-	65		μA
Shutdown Current	I_{SD}	EN#=5V	-	0.1	1	μA
Output Voltage						
On Resistance	R_{ON}	$I_{OUT}=0.5A$		38	45	$m\Omega$
Reverse Leakage Current	I_{REV}	$V_{OUT}=5V, V_{IN}=0V$	-	0.1	2	μA
Soft-Start Time		Rising from 10% to 90% $C_L=1\mu F; R_{LOAD}=10\Omega$	-	1.5		ms
Enable						
Enable High Level	V_{EN}		1.2	-	-	V
Disable Low Level	V_{SD}		-	-	0.5	V
EN Input Current	I_{EN}		-	0.1	1	μA
Flag Output						
Output Resistance	R_{FLGB}	$I_{SINK}=1mA$	-	20		Ω
Off Leakage Current	I_{FLGB_OFF}	$V_{FLGB}=5V$	-	0.1	1	μA
Delay Time	T_D		8	15	22	ms
OUT Shutdown Discharge Resistance	R_{DIS}			100		Ω
Protection						
OCP Threshold Level	I_{OCP}	EM5213J/AJ-10 Version	1.1	1.6	2.1	A
OCP Threshold Level	I_{OCP}	EM5213J/AJ-15 Version	1.6	2.1	2.8	A
Thermal Shutdown Hysteresis	T_{SDHYS}		-	30	-	$^{\circ}C$
Thermal Shutdown				150		$^{\circ}C$

Note 1. Stresses listed as the above "Absolute Maximum Ratings" may cause permanent damage to the device. These are for stress ratings. Functional operation of the device at these or any other conditions beyond those indicated in the operational sections of the specifications is not implied. Exposure to absolute maximum rating conditions for extended periods may remain possibility to affect device reliability.

Note 2. θ_{JA} is measured in the natural convection at $T_A=25^{\circ}C$ on a low effective thermal conductivity test board (Single layout, 1S) of JEDEC 51-3 thermal measurement standard.

Note 3. Devices are ESD sensitive. Handling precaution is recommended.

Note 4. The device is not guaranteed to function outside its operating conditions.

Note 5. EMC will review datasheet by quarter, and update new version.

Application Information

Input Under-Voltage Lockout (UVLO)

The under voltage lockout circuit shut-down the power switch until the input voltage reaches the UVLO turn on threshold.

Internal Charge Pump

The device built in an internal charge pump for internal N-MOSFT driving. The internal charge pump provides the necessary voltage to pull up the gate voltage above the input source. The charge pump also controls the rising time of the output voltage to limit large current and voltage surges on the input supply, and provides built-in soft-start functionality. The MOSFET will block the current from output to input during shut-down operation.

FLAG

The FLAG open-drain output is asserted during over current, short circuit or over temperature condition. A typical 9ms deglitch time on output rising edges avoids false reporting at startup.

Reverse Voltage Protection

When the output voltage exceeds the input voltage by 150mV, the reverse voltage circuitry will disconnects the internal Power MOS after 10us deglitch time in order to protect the input power supply. This protection circuit remains active until the voltage at output drops below the input voltage that about 800mV, the Power MOS will be turned back on.

Reverse Blocking Control

The reverse blocking control feature prevents the current to flow from output to input when device is disabled.

Over current and short circuit Protection

EM5213 switches into a constant current limitation mode when the output current is above the I_{OC} threshold. The difference overcurrent conditions and the corresponding response as below,

- In case of short circuit or huge load, the higher current may flow for a very short period response time about 2us. After this duration time, the switch turn into constant current limit mode and the short current is clamped at I_{SC} Level. If the output remains shorted or tied to a ground level, the junction temperature of the device exceeds T_{SD} value and device enters in thermal shutdown cycle.
- In case of hot plug with heavy capacitive load, the output voltage is brought down to the capacitor voltage. The device will limit the current to the I_{SC} Level until the charge of the capacitor is completed.
- In case of load increase gradually, once the current over the I_{OC} Level, the device turn into constant current limit mode, until the load current decreasing down to below the I_{SC} Level, then the output will be ramp up to the target voltage level automatically.

Over Temperature Protection

Over temperature protection prevent the IC from damage when the junction temperature over the 150 degree, the internal thermal sense turns the power switch off and the FLT output is asserted, thus preventing the power switch from damage. Hysteresis in the thermal sense circuit allows the device to cool down by approximately 20degree before the output is re-started.

Ordering & Marking Information

Device Name: EM5213J/AJ-15A & EM5213J/AJ-10A for SOT23-5

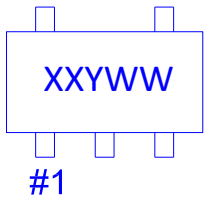

XX: Device Code

Device	Code
EM5213AJ-10A	NR
EM5213J-10A	NS
EM5213AJ-15A	GR
EM5213J-15A	GS

YWW: Date Code

Outline Drawing

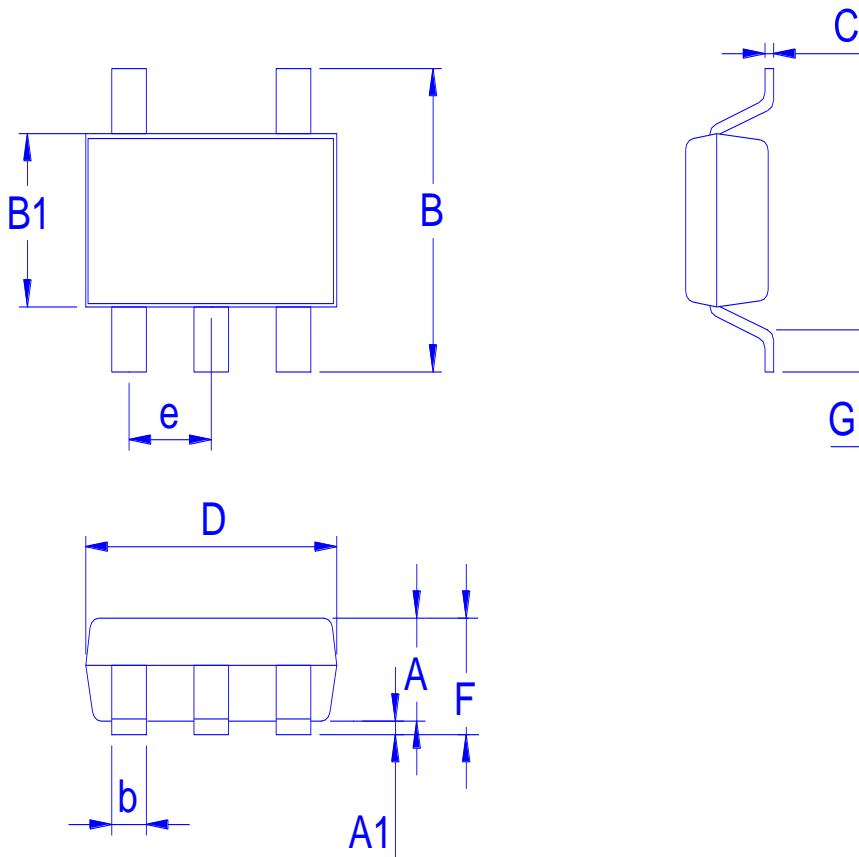

Dimension in mm

Dimension	A	A1	B	B1	b	C	D	e	F	G
Min.	0.90	0.00	2.60	1.50	0.30	0.08	2.80	0.87	1.00	0.30
Typ.	1.10	0.04	2.80	1.60	0.40	0.127	2.90	0.95	1.225	0.45
Max.	1.30	0.15	3.00	1.726	0.50	0.22	3.026	1.03	1.45	0.60

◆ Tape&Reel Information:3000pcs/Reel(Dimension in millimeter)

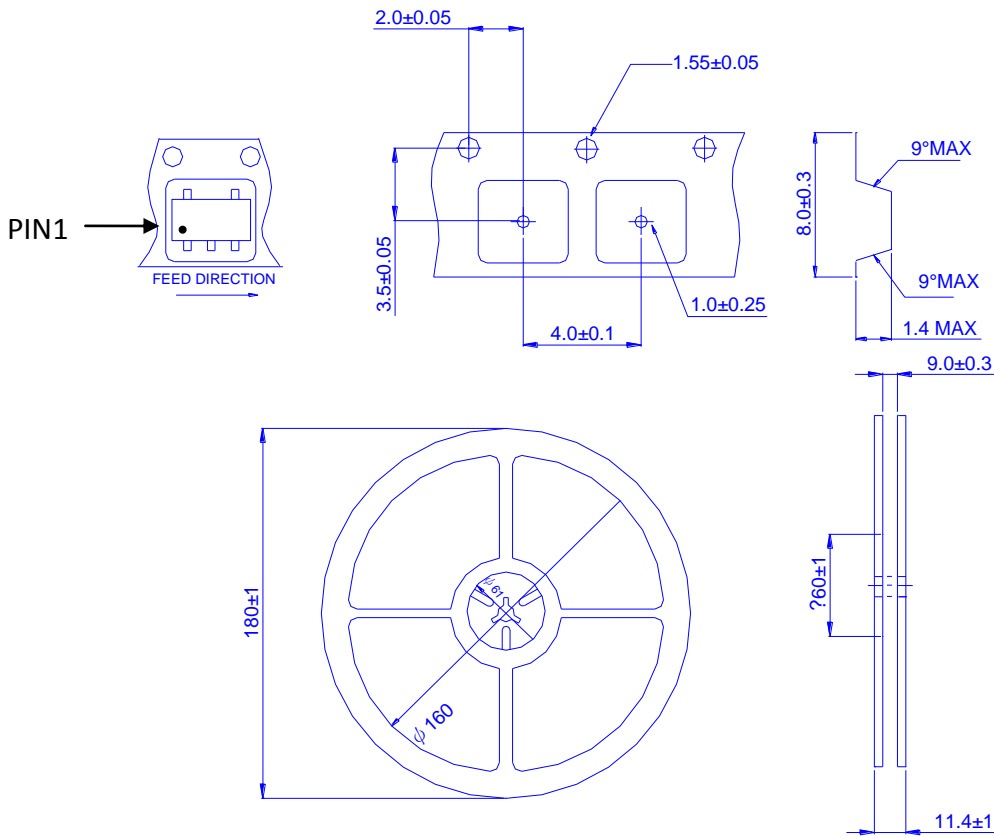

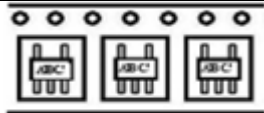
Package	SOT23-5
Reel Dimensions	7"
Pin1 Orientation	
Leader Empty Pockets	50
Trailer Empty Pockets	50
Quantity per Reel	3K
Reel / Inner Box	5 : 1
Quantity per Inner Box	15K
Inner Box/ Outer Carton	12 : 1
Quantity per Outer Carton	180K