

## 85A 80V N-channel Enhancement Mode Power MOSFET

### 1 Description

These N-channel enhancement mode power MOSFETS Used advanced trench technology design, provided excellent RDSON and low gate charge. Which accords with the RoHS standard.

### 2 Features

- Low On Resistance
- Low Gate Charge
- High avalanche Current
- Fast Switching
- Low Reverse Transfer Capacitances
- 100% Single Pulse Avalanche Energy Test
- 100%  $\Delta V_{DS}$  Test

### 3 Applications

- Power switching applications
- DC-DC converters
- UPS power supply

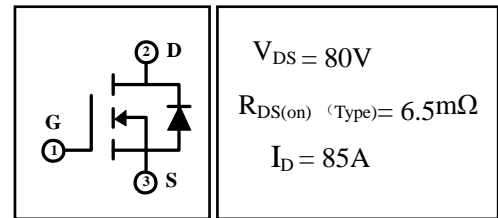

### 4 Electrical Characteristics

#### 4.1 Absolute Maximum Ratings (Tc=25°C, unless otherwise noted)

Parameter	Symbol	Value	Unit	
Drain-Source Voltage	$V_{DSS}$	80	V	
Gate-Source Voltage	$V_{GS}$	$\pm 25$	V	
Drain Current(continuous) <sup>(3)</sup>	$I_D$	85	A	
Drain Current(continuous)(T=100°C) <sup>(3)</sup>	$I_D(100^\circ C)$	70	A	
Drain Current(Pulsed) <sup>(4)</sup>	$I_{DM}$	340	A	
Avalanche Current <sup>(5)</sup>	$I_{AS}$	20	A	
Single Pulse Avalanche Energy <sup>(5)</sup>	$E_{AS}$	410	mJ	
Maximum Power Dissipation	T <sub>a</sub> =25°C	P <sub>D</sub>	2	W
	T <sub>c</sub> =25°C	P <sub>D</sub>	240	W
Operating Junction Temperature Range	T <sub>J</sub>	-55~175	°C	
Storage Temperature Range	T <sub>stg</sub>	-55~175	°C	
High Temperature(tin solder)	T <sub>L</sub>	300	°C	

**4.2 Thermal Characteristics**

Parameter	Symbol	Value	Unit
Thermal Resistance Junction-to-Case	$R_{\theta JC}$	0.63	$^{\circ}\text{C/W}$
Thermal Resistance Junction-to-Ambient	$R_{\theta JA}$	75	$^{\circ}\text{C/W}$

**4.3 Electrical Characteristics** ( $T_C=25^{\circ}\text{C}$ , unless otherwise noted)

Parameter	Symbol	Test Condition	Value			Unit
			Min.	Typ.	Max.	
<b>Off Characteristics</b>						
Drain-source Breakdown Voltage	$V_{DSS}$	$I_D=250\mu\text{A}, V_{GS}=0\text{V}$	80	--	--	V
Zero Gate Voltage Drain Current	$I_{DSS}$	$V_{DS}=80\text{V}, V_{GS}=0\text{V}, T_C=25^{\circ}\text{C}$	--	--	1	$\mu\text{A}$
		$V_{DS}=64\text{V}, V_{GS}=0\text{V}, T_C=125^{\circ}\text{C}$	--	--	100	$\mu\text{A}$
Gate-to-Body Leakage Current	$I_{GSS}$	$V_{GS}=\pm 25\text{V}, V_{DS}=0\text{V}$	--	--	$\pm 100$	nA
<b>On Characteristics</b> <sup>(3)</sup>						
Gate threshold voltage	$V_{GS(th)}$	$V_{DS}=V_{GS}, I_D=250\mu\text{A}$	2	3	4	V
Drain-Source on Resistance	$R_{DS(on)}$	$V_{GS}=10\text{V}, I_D=40\text{A}$	--	6.5	7.8	$\text{m}\Omega$
Gate Resitance	$R_G$	$V_{DD}=0\text{V}, V_{GS}=0\text{V}, f=1\text{MHz}$	--	1.3	--	$\Omega$
<b>Dynamic Characteristics</b> <sup>(4)</sup>						
Input Capacitance	$C_{iss}$	$V_{GS}=0\text{V}, V_{DS}=25\text{V}, f=1\text{MHz}$	--	3110	--	pF
Output Capacitance	$C_{oss}$		--	445	--	
Reverse Transfer Capacitance	$C_{rss}$		--	270	--	
<b>Switching Characteristics</b> <sup>(4)</sup>						
Turn-on Delay Time	$t_{d(on)}$	$I_D=40\text{A}, V_{DS}=40\text{V}, V_{GS}=10\text{V}, R_{GEN}=6.8\Omega$	--	20.4	--	nS
Turn-on Rise Time	$t_r$		--	63	--	
Turn-off Delay Time	$t_{d(off)}$		--	67	--	
Turn-off Fall Time	$t_f$		--	43	--	
Total Gate Charge	$Q_g$	$I_D=40\text{A}, V_{DS}=40\text{V}, V_{GS}=10\text{V}$	--	76	--	nC
Gate-to-Source Charge	$Q_{gs}$		--	9.5	--	
Gate-to-Drain("Miller")Charge	$Q_{gd}$		--	40	--	
<b>Drain-Source Diode Characteristics</b>						
Diode Forward Voltage <sup>(3)</sup>	$V_{SD}$	$V_{GS}=0\text{V}, I_S=85\text{A}$	--	--	1.3	V
Diode Forward Current <sup>(2)</sup>	$I_S$		--	--	85	A
Reverse Recovery Time	$t_{rr}$	$T_J=25^{\circ}\text{C}, I_F=40\text{A}, dI_F/dt=100\text{A}/\mu\text{S}, V_{GS}=0\text{V}$	--	25	--	nS
Reverse Recovery Charge	$Q_{rr}$		--	18.5	--	nC

Notes:

- 1: Repetitive rating, pulse width limited by maximum junction temperature.
  - 2: Surface mounted on FR4 Board,  $t \leq 10\text{sec}$ .
  - 3: Pulse width  $\leq 300\mu\text{s}$ , duty cycle  $\leq 2\%$ .
  - 4: Guaranteed by design, not subject to production.
- 5:  $L=0.5\text{mH}, I_D=40.5\text{A}, V_{DD}=50\text{V}, V_{GS}=10\text{V}, \text{Start } T_J=25^{\circ}\text{C}$ .

**5 Typical characteristics diagrams**

**Output Characteristics**

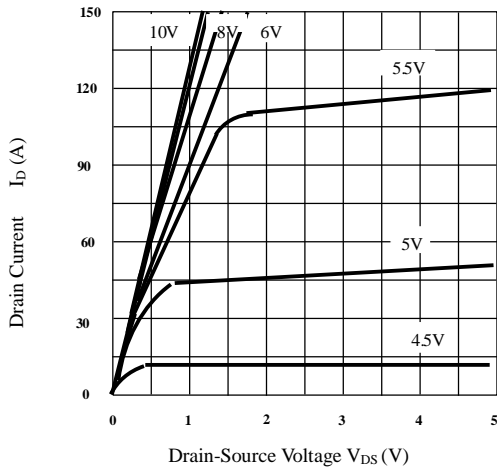

**Drain-Source On Resistance vs.  $I_D$**

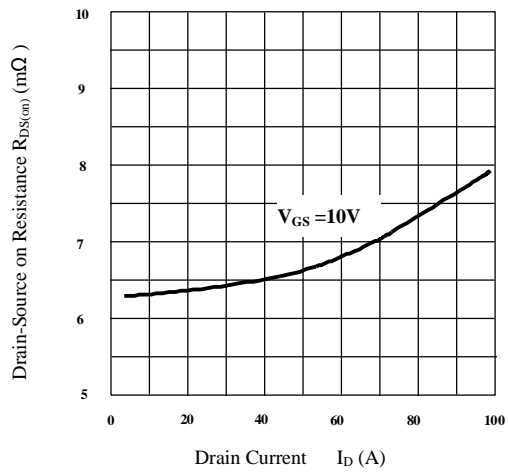

**Drain-Source On Resistance vs.  $V_{GS}$**

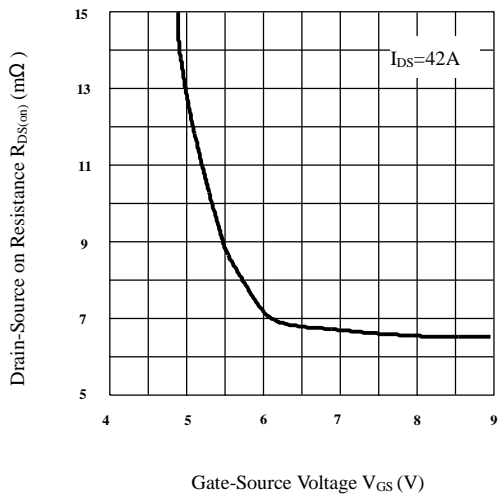

**Drain-Source On Resistance vs.  $T_J$**

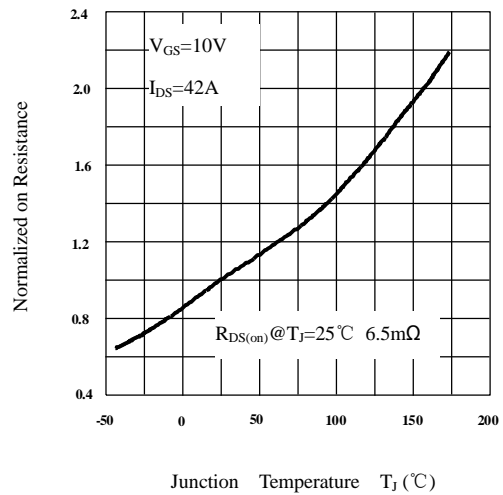

**Drain-Source Diode Forward**

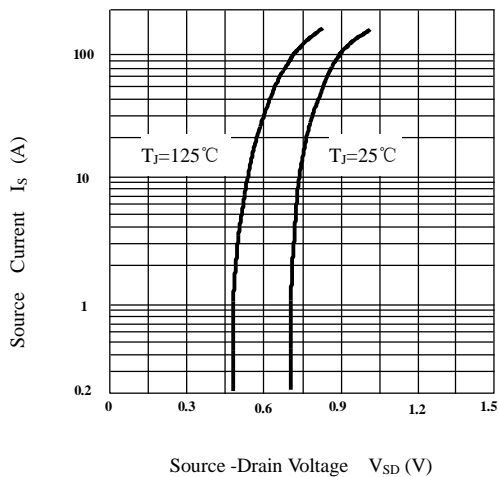

**Maximum Drain Current vs.  $T_J$**

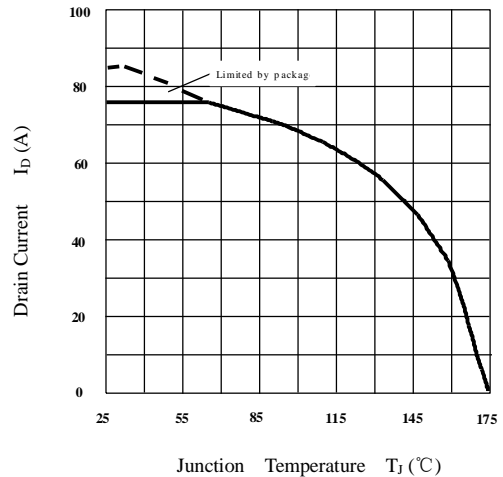

**5 Typical characteristics diagrams(continues)**

**Capacitance vs.  $V_{DS}$**

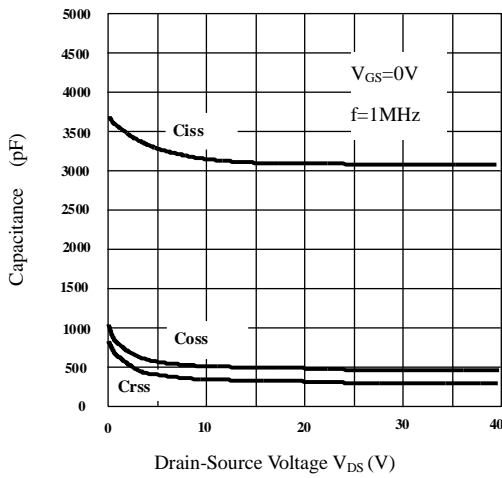

**Gate Charge Characteristics**

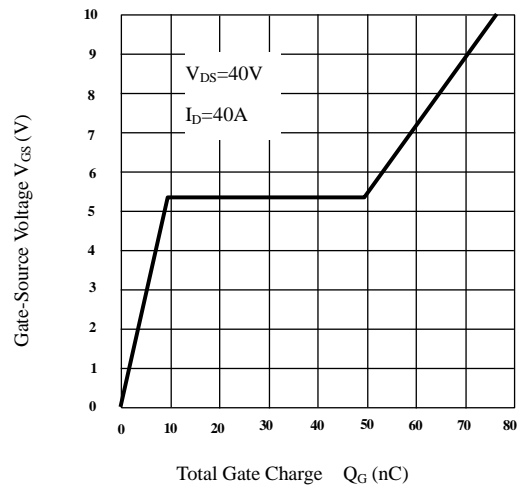

**Transfer Characteristics**

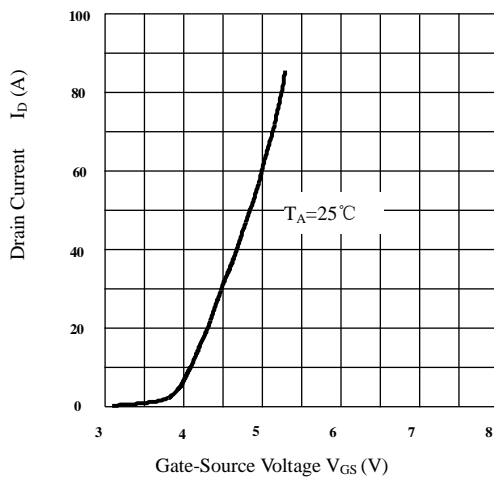

**Power Dissipation**

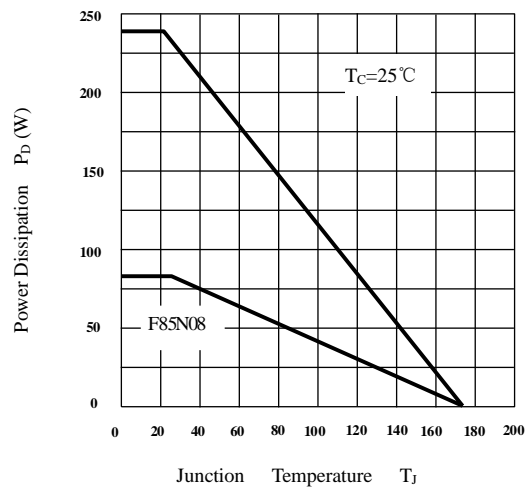

**Safe Operation Area**

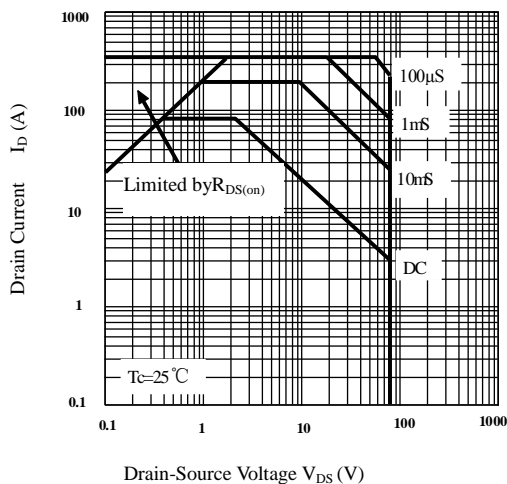

**Transient Thermal Response Curve**

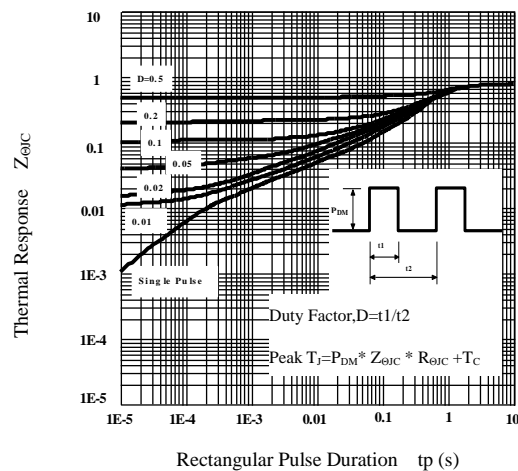

**6 Typical Test Circuit and Waveform**

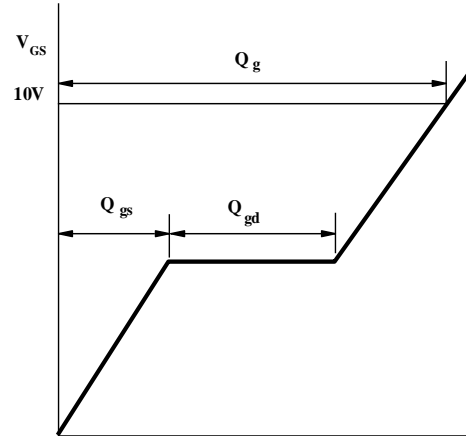
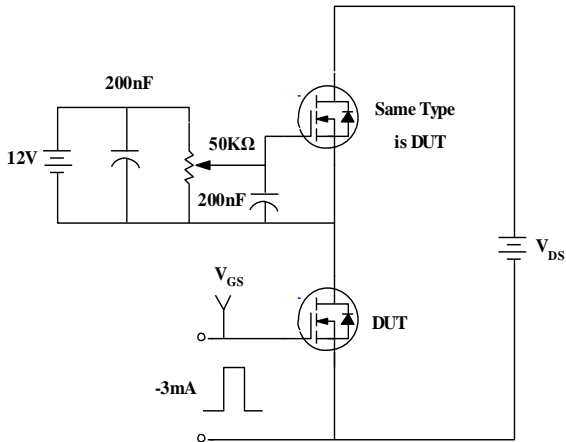

**1) Gate Charge Test Circuit & Waveform**

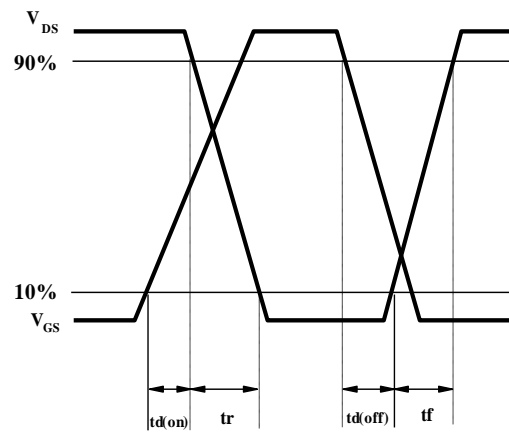
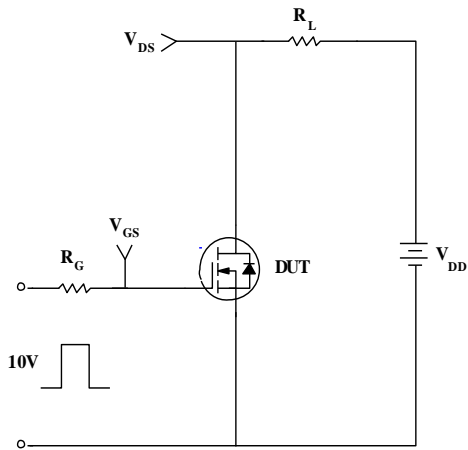

**2) Switching Test Circuit & Waveforms**

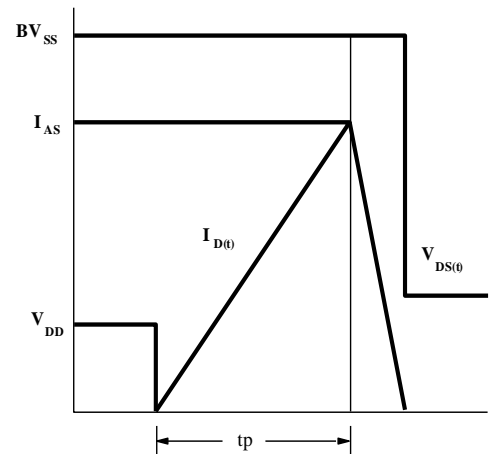
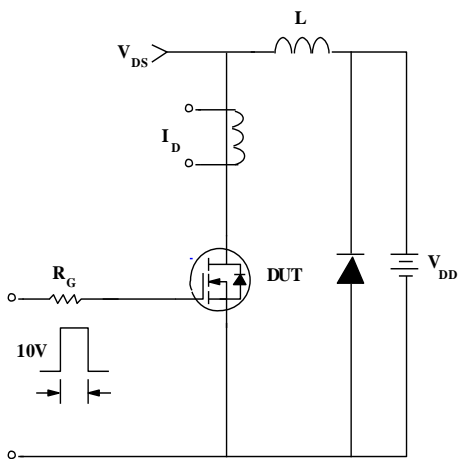

**3) Unclamped Inductive Test Circuit & Waveforms**

## 7 Product Names Rules

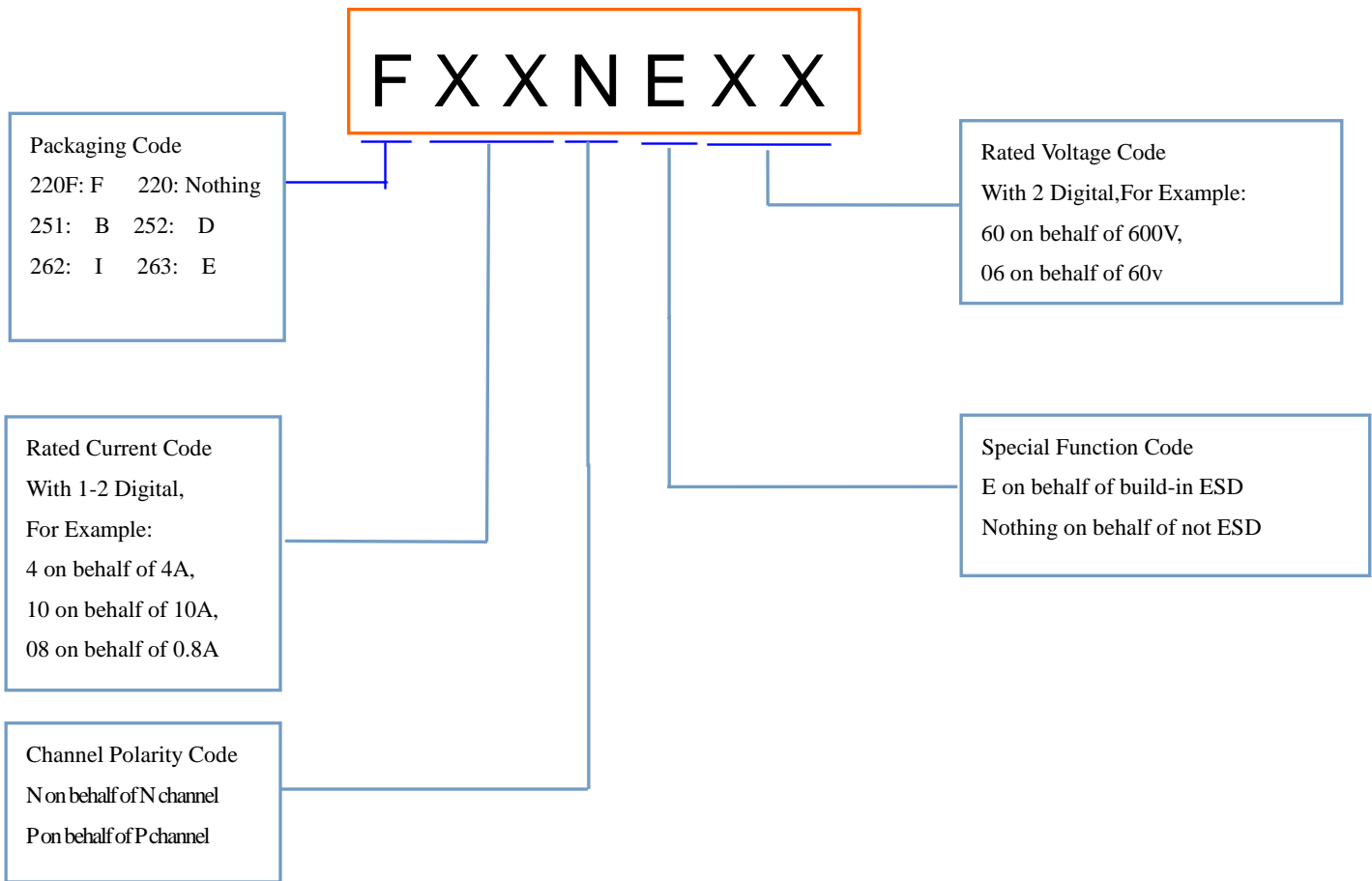

## 8 Product Specifications and Packaging Models

Product Model	Package Type	Mark Name	RoHS	Package	Quantity
85N08	TO-220C	85N08	Pb-free	Tube	1000/box
F85N08	TO-220F	F85N08	Pb-free	Tube	1000/box
I85N08	TO-262	I85N08	Pb-free	Tube	1000/box
E85N08	TO-263	E85N08	Pb-free	Tape & Reel	800/box

9 Dimensions

TO-220C PACKAGE OUTLINE DIMENSIONS

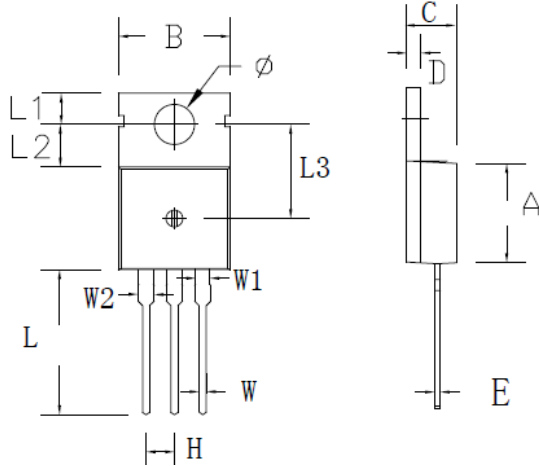

Symbol	Dimensions In Millimeters		Dimensions In Inches	
	min.	max.	min.	max.
A	8.80	9.30	0.346	0.366
B	9.70	10.30	0.382	0.406
C	4.25	4.75	0.167	0.187
D	1.20	1.45	0.047	0.057
E	0.40	0.60	0.016	0.024
H	2.54 TYP		0.100 TYP	
W	0.60	0.95	0.024	0.037
W1	1.05	1.45	0.041	0.057
W2	1.20	1.60	0.047	0.063
L	12.60	13.40	0.496	0.528
L1	2.45	2.95	0.096	0.116
L2	3.45	3.95	0.136	0.156
L3	8.15	8.65	0.321	0.341
φ	3.50	3.90	0.138	0.154

TO-220F PACKAGE OUTLINE DIMENSIONS

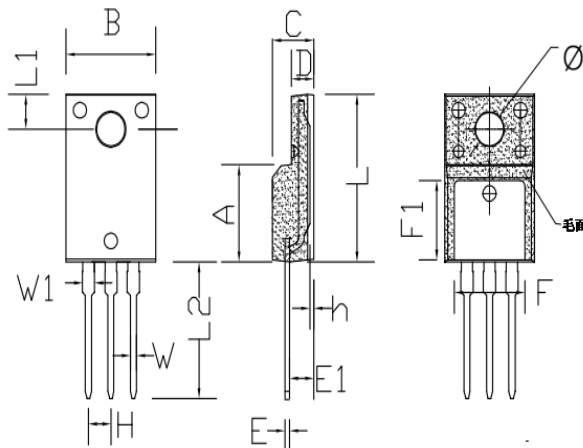

Symbol	Dimensions In Millimeters		Dimensions In Inches	
	min.	max.	min.	max.
A	8.80	9.30	0.346	0.366
B	10.00	10.50	0.394	0.413
C	4.30	4.90	0.169	0.193
D	2.30	2.70	0.091	0.106
L	15.55	16.15	0.612	0.636
h	0.40	0.60	0.016	0.024
L1	3.15	3.55	0.124	0.140
L2	12.65	13.35	0.498	0.526
W	0.70	0.90	0.028	0.035
W1	1.15	1.55	0.045	0.061
H	2.54 TYP		0.100 TYP	
E	0.48	0.53	0.019	0.021
φ	2.90	3.40	0.114	0.134
E1	2.40	2.90	0.094	0.114
F	7.75	8.25	0.305	0.325
F1	7.35	7.85	0.289	0.309

9 Dimensions(continues)

TO-262 PACKAGE OUTLINE DIMENSIONS

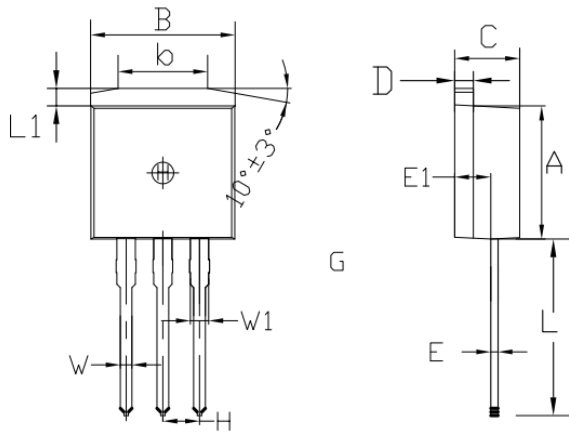

Symbol	Dimensions In Millimeters		Dimensions In Inches	
	min.	max.	min.	max.
A	8.80	9.30	0.346	0.366
B	9.70	10.30	0.382	0.406
C	4.25	4.75	0.167	0.187
D	1.20	1.45	0.047	0.057
E	0.40	0.60	0.016	0.024
L	12.25	13.75	0.482	0.541
L1	1.15	1.45	0.045	0.057
E1	2.4	2.6	0.0945	0.1024
W	0.80	0.82	0.0315	0.034
W1	1.20	1.30	0.047	0.051
H	2.54 TYP		0.200 TYP	
b	5.50	6.50	0.216	0.256

TO-263 PACKAGE OUTLINE DIMENSIONS

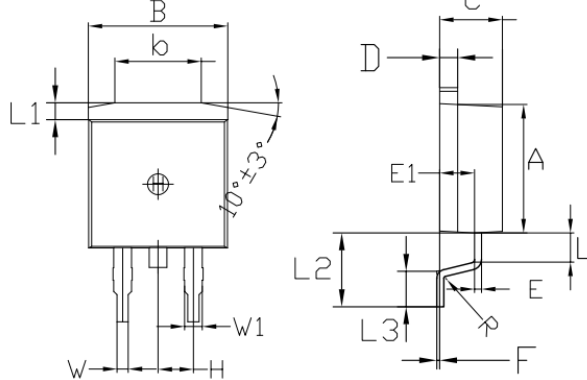

Symbol	Dimensions In Millimeters		Dimensions In Inches	
	min.	max.	min.	max.
A	8.80	9.30	0.346	0.366
B	9.70	10.30	0.382	0.406
C	4.25	4.75	0.167	0.187
D	1.20	1.45	0.047	0.057
E	0.40	0.60	0.016	0.024
L	1.90	2.30	0.075	0.091
L1	1.15	1.45	0.045	0.057
R	0.24	0.26	0.0095	0.0102
W	0.80	0.82	0.0315	0.0323
W1	1.20	1.30	0.047	0.051
H	2.54 TYP		0.200 TYP	
b	5.50	6.50	0.216	0.256
E1	2.4	2.6	0.0946	0.1024
L2	5.20	5.80	0.205	0.228
L3	2.20	3.20	0.087	0.126
F	0.03	0.23	0.0012	0.0091

## 10 Attentions

- ROUM Semiconductor Technology CO.,LTD. reserves the right to change the specification without prior notice! The customer should obtain the latest version of the information before making the order and verify that the information is complete and up to date.
- It is the responsibility of the purchaser for any failure or failure of any semiconductor product under certain conditions. It is the responsibility of the purchaser to comply with safety standards and to take safety measures in the system design and machine manufacturing of Roma products in order to avoid potential risk of failure. Injury or property damage.
- Product promotion is endless, our company will be dedicated to provide customers with better products.

## 11 Appendix

Revision history:

Date	REV.	Description	Page
2017.03.09	1.0	Original	