

## High-Efficiency, 40V White LED Driver with Dimming Control

### Description

The FP6745C is a step-up DC/DC converter specifically designed for driving WLEDs with a constant current. The FP6745C can drive up to 10 white LEDs in series from a Lithium Ion battery. Series connection of LEDs provides identical LED current for uniform brightness and minimizes the number of traces to the LEDs. The FP6745C uses current mode, fixed frequency of approximately 1.3MHz architecture to regulate the LED current through an external current sense resistor. The low feedback voltage of 300mV can minimize power dissipation.

Other features include current limit protection, thermal shutdown protection, under-voltage lockout (UVLO), and over-voltage function, which can shut off the device if output voltage reaches above 41V. The FP6745C is available in space saving SOT-23-6 packages.

### Features

- Wide Range for PWM Dimming, Ranging from 100Hz to 50kHz
- High Efficiency: 87%
- Drives Up to 10 WLEDs
- Fast 1.3MHz Switching Frequency
- Low 300mV Feedback Voltage
- Over Voltage Protection
- Low Profile SOT-23-6 Packages
- RoHS Compliant

### Applications

- Cellular Phones
- Digital Cameras
- LCD Panel Backlights
- GPS Receivers
- PDAs, Handheld Computers

### Pin Assignments

#### S6 Package (SOT-23-6)

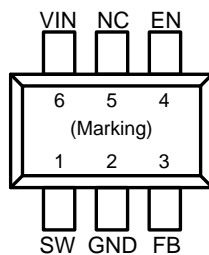
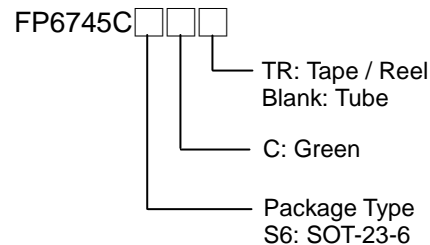

Figure 1. Pin Assignment of FP6745C

### Ordering Information



#### SOT-23-6 Marking

Part Number	Product Code
FP6745CS6C	A0A

**Typical Application Circuit**

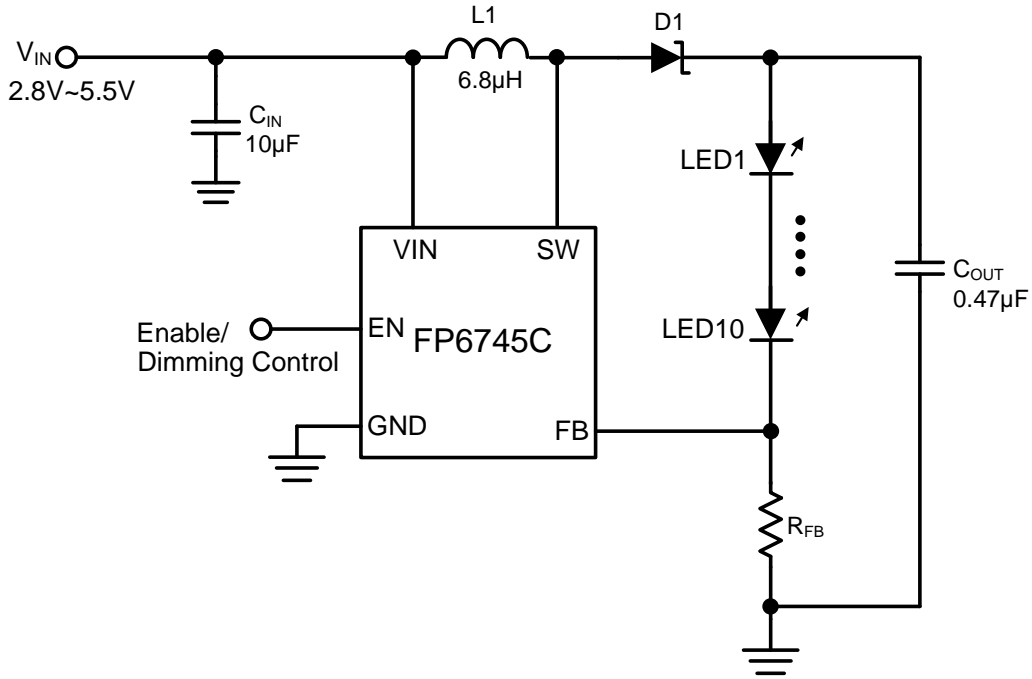

Figure 2. Typical Application Circuit of FP6745C

**Functional Pin Description**

Pin Name	Pin Function
<b>SW</b>	Switch Pin. Connect inductor/diode here. Minimize trace area at this node to reduce EMI.
<b>GND</b>	Ground Pin. Connect directly to local ground plane.
<b>FB</b>	Feedback Pin. Reference voltage is 300mV. Connect cathode of the lowest LED and resistor here. Calculate resistor value according to the formula: $R_{FB} = V_{FB} / I_{LED}$
<b>EN</b>	Enable and dimming control 1. Enable: Logic high enables the device; logic low forces the device into shutdown mode. 2. Analog dimming control: apply 0.7V to 1.4V DC voltage signal. 3. Digital dimming control: apply external 100Hz to 50kHz PWM pulse signal with amplitude greater than 1.5V.
<b>VIN</b>	Input Supply Pin. Must be locally bypassed.

**Block Diagram**

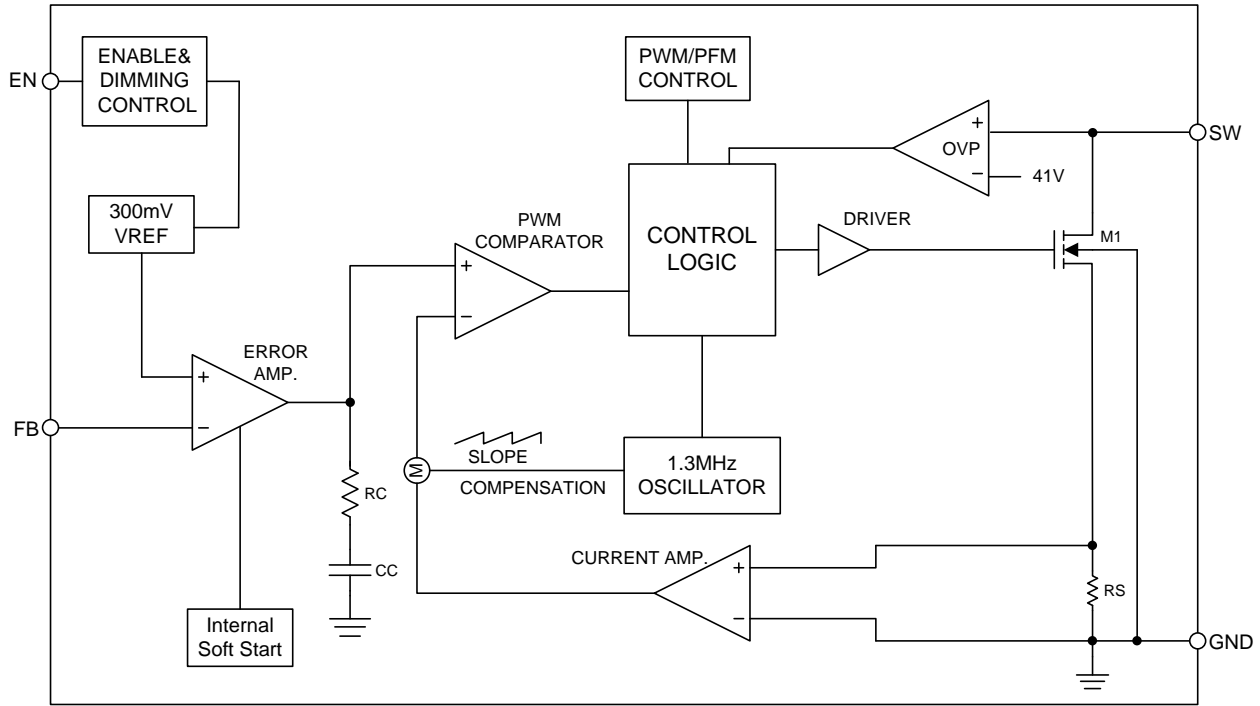

Figure 3. Block Diagram of FP6745C

**Absolute Maximum Ratings**

- VIN ----- +6V
- SW Voltage ----- +43V
- FB Voltage ----- +6V
- EN Voltage ----- +6V
- Maximum Junction Temperature (T<sub>J</sub>) ----- +150°C
- Power Dissipation @T<sub>A</sub>=25°C:
  - SOT-23-6 (P<sub>D</sub>) ----- +0.40W
- Package Thermal Resistance (θ<sub>JA</sub>):
  - SOT-23-6 ----- +250°C/W
- Storage Temperature Range (T<sub>S</sub>) ----- -65°C to +150°C
- Lead Temperature (Soldering, 10 sec.) (T<sub>LEAD</sub>) ----- +260°C

Note 1 : Stresses beyond those listed under "Absolute Maximum Ratings" may cause permanent damage to the device.

**Recommended Operating Conditions**

- Input Voltage (V<sub>IN</sub>) ----- +2.8V to +5.5V
- Operating Temperature Range ----- -40°C to +85°C

## Electrical Characteristics

( $V_{IN}=V_{EN}=5V$ ,  $T_A=+25^{\circ}C$ , unless otherwise noted)

Parameter	Symbol	Conditions	Min	Typ	Max	Unit
Operating Input Voltage	$V_{IN}$		2.8		5.5	V
Operation Current	$I_{SD}$	$V_{EN}=0V$		4	8	$\mu A$
	$I_Q$	$V_{FB}=0.2V$		430	550	$\mu A$
Switching Frequency	$f_{SW}$		1.0	1.3	1.5	MHz
Maximum Duty Cycle	Duty	$V_{FB}=0V$	92			%
<b>Under Voltage Lockout</b>						
VIN Under Voltage Lockout	UVLO	$V_{IN}$ Rising		2.25	2.45	V
Under Voltage Lockout Hysteresis				92		mV
Open Lamp Shutdown Threshold	$V_{OV}$	$V_{SW}$ Rising	40	41		V
<b>Enable</b>						
EN OFF Threshold		$V_{EN}$ Falling	0.4			V
EN ON Threshold		$V_{EN}$ Rising			0.6	V
Minimum EN Dimming Threshold		$V_{FB}=0V$		0.7		V
Maximum EN Dimming Threshold		$V_{FB}=300mV$		1.4		V
<b>Feedback</b>						
FB Voltage	$V_{FB}$	$V_{EN}=1.5V$	285	300	315	mV
FB Input Bias Current	$I_{FB}$	$V_{FB}=0.1V$		-300		nA
<b>Output Switch</b>						
SW ON-Resistance (Note2)	$R_{ON}$			0.5		$\Omega$
SW Current Limit (Note2)	$I_{LM}$			1.33		A
Thermal Shutdown (Note2)	$T_{SD}$			150		$^{\circ}C$

Note 2 : The specification is guaranteed by design, not production tested.

## Applications Information

### Operation

The FP6745C is designed in a current mode, fixed-frequency pulse-width modulation (PWM) step-up converter to drive up to 10 series-connected WLEDs. The FP6745C operates well with a variety of external components. See the following sections to optimize external components for a particular application.

### Inductor Selection

For most applications, a 4.7μH to 15μH is recommended for general use. The inductor parameters, current rating, DCR and physical size, should be considered. The DCR of inductor affects the efficiency of the converter. The inductor with lowest DCR is chosen for highest efficiency. The saturation current rating of inductor must be greater than the switch peak current, typically 1.33A. These factors affect the efficiency, output load capability, output voltage ripple, and cost.

The inductor selection depends on the switching frequency and current ripple by the following formula:

$$L \geq \frac{V_{IN}}{f_{SW} \times \Delta I_L} \left( 1 - \frac{V_{IN}}{V_{OUT}} \right)$$

Where  $f_{SW}$  is the 1.3MHz switching frequency.

$\Delta I_L$  is the inductor ripple current.

### Capacitor Selection

The ceramic capacitor is ideal for FP6745C application. X5R or X7R types are recommended because they hold their capacitance over wide voltage and temperature ranges than other Y5V or Z5U types. The input capacitor can reduce peak current and noise at power source. The output capacitor is typically selected based on the output voltage ripple requirements. For most applications, a 10μF input capacitors with a 0.47μF output capacitor are sufficient for general use. A higher or lower capacitance may be used depending on the acceptable noise level.

### LED Current Setting

The LED current is specified by resistor from the FB pin to ground. In order to have accurate LED current, precision resistors are preferred (1% is recommended). The LED current can be programmed by:  $I_{LED} = 300mV / R_{FB}$

### Over Voltage Protection

The FP6745C has an internal open-lamp protection circuit. In the cases of output open circuit, when the LEDs are disconnected from the circuit or the LEDs fail open circuit, the over-voltage function monitors the output voltage through SW pin to protect the converter against. The LED strings open will cause N-MOS to switch with a maximum duty cycle and come out output over-voltage. This may cause the SW voltage exceed its maximum rating then damage built-in N-MOS. In the state, the OVP protection circuitry will be triggered if output voltage exceeds 41V (typ.). The FP6745C will then stop switching and latch off. The FP6745C will automatically recover normal operation until EN input is recycled or the  $V_{IN}$  is re-started.

### Dimming Control

There are two different types of dimming control circuits. The LED current can be set by modulating the EN pin with a DC voltage or a PWM signal.

#### (1) DC Voltage

The dimming control uses a DC voltage ranging from 0.7V to 1.4V which results in regulating FB voltage from 0V to 300mV, respectively.

#### (2) PWM Signal

Changing the LED forward current not only changes the intensity of the LEDs, but also changes the color. Controlling the intensity of the LEDs with a direct PWM signal allows dimming of the LEDs without changing the color.

Dimming the LEDs via a PWM signal essentially involves turning the LED on and off. The LEDs operate at either zero or full current. The amplitude of the PWM signal should be higher than the minimum EN dimming voltage (typically 1.4V). The LED average current increases proportionally with the duty cycle of the PWM signal. The recommended duty cycle range is from 5% to 100%. The color of the LEDs remains unchanged since the LED current value is either zero or a constant value. The dimming frequency of the PWM signal can up to 50kHz and still retain well linearity. To avoid audio noise, dimming frequency greater than 20kHz is recommended.

## Applications Information (Continued)

### Layout Consideration

The proper PCB layout and component placement are critical for all switching regulators. The careful attention should be taken to the high-frequency, high current loops to prevent electromagnetic interference (EMI) problems. Here are some suggestions to the layout of FP6745C design.

- a. The input capacitor should be located as closed as possible to the VIN and GND pin.
- b. Minimize the distance of all traces connected to the SW node. The external components,  $C_{OUT}$ , L1, and D1 should be placed as close to the device as possible with short and wide route to obtain optimum efficiency.
- c. Keep the noise-sensitive feedback circuitry away from the switching node. Place feedback resistor as close as possible to FB pin.
- d. The ground terminal of  $C_{OUT}$  must be located as closed as possible to GND pin. Place  $C_{OUT}$  next to Schottky diode.

In Backlight application, the system engineers usually place the  $C_{OUT}$  close to the LED connector. The far  $C_{OUT}$  of the FP6745C may result in variable VFB. Add one more  $C_{OUT}$  close to FP6745C is recommended.

**Outline Information**

SOT-23-6 Package (Unit: mm)

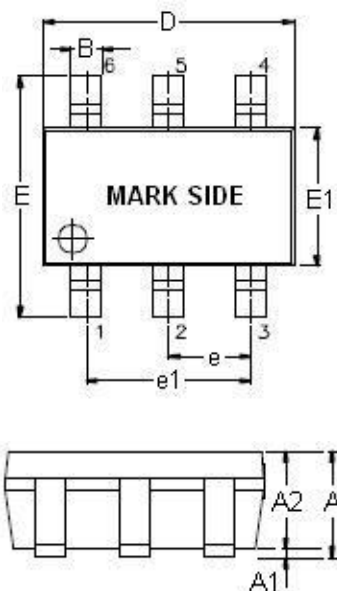

SYMBOLS UNIT	DIMENSION IN MILLIMETER	
	MIN	MAX
A	0.90	1.45
A1	0.00	0.15
A2	0.90	1.30
B	0.30	0.50
D	2.80	3.00
E	2.60	3.00
E1	1.50	1.70
e	0.90	1.00
e1	1.80	2.00
L	0.30	0.60

Note : Followed From JEDEC MO-178-C.

**Carrier dimensions**

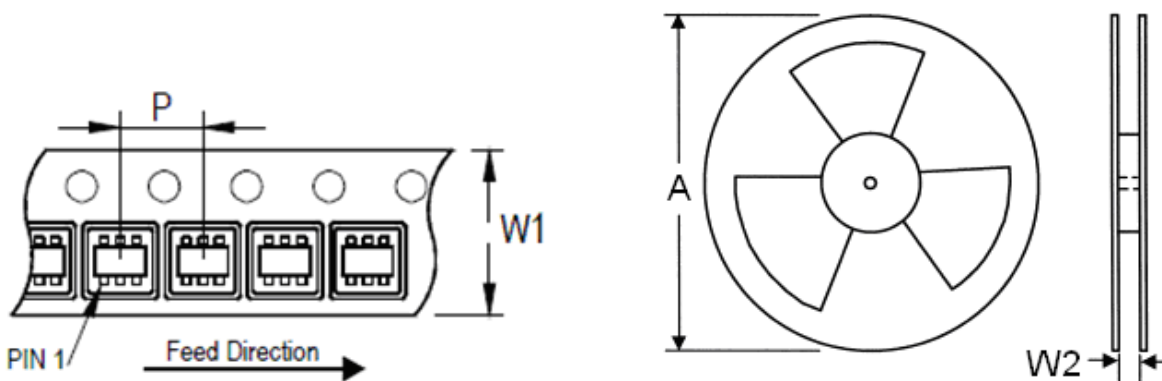

Tape Size (W1) mm	Pocket Pitch (P) mm	Reel Size (A)		Reel Width (W2) mm	Empty Cavity Length mm	Units per Reel
		in	mm			
8	4	7	180	8.4	300~1000	3,000

**Life Support Policy**

Fitipower's products are not authorized for use as critical components in life support devices or other medical systems.