

**PWM Boost
DC-DC Controller**

Description

The FP6791C is a CMOS step-up switching controller which incorporates a reference voltage circuit, an oscillator, an error amplifier, a PWM controller, an under voltage lockout circuit (UVLO) and a timer latch short-circuit protection circuit.

The switching frequency can be controlled by the resistor connected to the ROSC pin, and the maximum duty ratio can be controlled by the resistor connected to the RDUTY pin.

In addition, the FP6791C provides adjustable short-circuit protection delay time with an external capacitor which is connected to the CSP pin. If the maximum duty condition continues due to short-circuiting, the capacitor externally connected to the CSP pin will be charged, and oscillation will stop after a specific time. This condition will be cleared by re-application of power. This controller IC allows various settings and employs a small package, which make it easy to use.

Features

- Programmed Switching Frequency
- Programmed Maximum Duty Ratio
- Reference Voltage: 1.0V \pm 1.5%
- UVLO (Under-Voltage Lockout) Function:
 - Detection Voltage 2.2V
 - Hysteresis Width 0.3V
- Timer Latch Short-Circuit Protection Circuit: Delay Time Set by an External Capacitor.
- Internal Soft-Start Function
- External Compensation Network
- Small Package: 8-pin TSSOP
- RoHS Compliant

Applications

- LCD Panel
- Portable Equipment

Pin Assignment

TS Package (TSSOP-8)

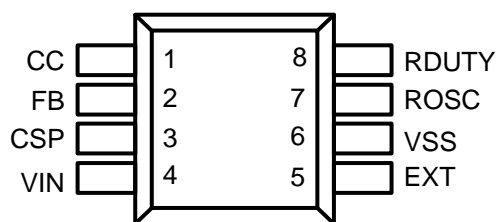
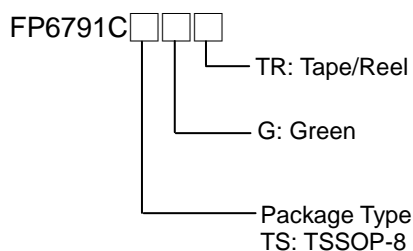

Figure 1. Pin Assignment of FP6791C

Ordering Information



Typical Application Circuit

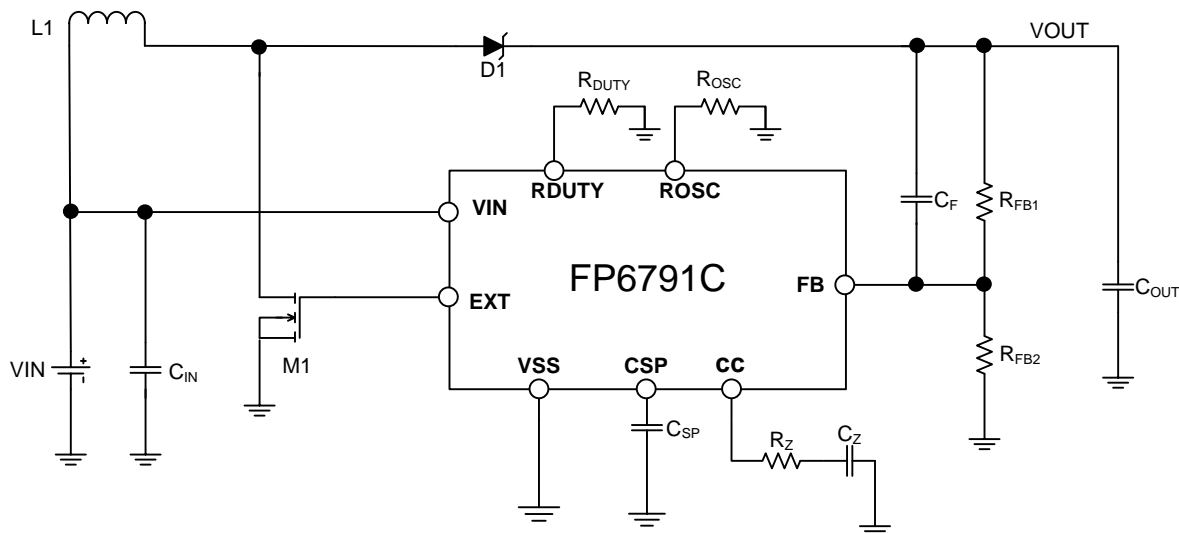

Figure 2. Typical Application Circuit of FP6791C

External Parts List:

Element Name	Symbol	Application1 : $V_{IN}=5V, V_{OUT}=12V,$ Frequency~700kHz	Application2 : $V_{IN}=3.3V, V_{OUT}=10.5V$ Frequency~1.1MHz
Inductor	L1	4.7 μ H, TDK	10 μ H, TDK
Diode	D1	Schottky Diode	Schottky Diode
Output Capacitor	C _{OUT}	40 μ F	10 μ F
Transistor	M1	Power MOS	Power MOS
Oscillation Frequency Setting Resistor	R _{OSC}	180k Ω ±1% resistor	120k Ω ±1% resistor
Maximum Duty Ratio Setting Resistor	R _{DUTY}	220k Ω ±1% resistor	110k Ω ±1% resistor
Short-Circuit Protection Delay Setting Capacitor	C _{SP}	0.1 μ F ceramic capacitor	0.1 μ F ceramic capacitor
Output Voltage Setting Resistor1	R _{FB1}	8.2k Ω ±1% resistor	6.8k Ω ±1% resistor
Output Voltage Setting Resistor2	R _{FB2}	750k Ω ±1% resistor	715k Ω ±1% resistor
FB Pin Capacitor	C _{FB}	2.2nF ceramic capacitor	1nF ceramic capacitor
Phase Compensation Resistor	R _Z	56k Ω ±1% resistor	100k Ω ±1% resistor
Phase Compensation Capacitor	C _Z	10nF ceramic capacitor	10nF ceramic capacitor
Input Capacitor	C _{IN}	10 μ F ceramic capacitor	10 μ F ceramic capacitor

Functional Pin Description

Pin Name	Pin Function
CC	Error amplifier circuit output and phase compensation pin
FB	Output voltage feedback pin
CSP	Short-circuit protection delay time setting pin
VIN	Power supply input pin
EXT	External transistor connection pin
VSS	GND pin
ROSC	Oscillation frequency setting resistor connection pin
RDUTY	Maximum duty setting resistor connection pin

Block Diagram

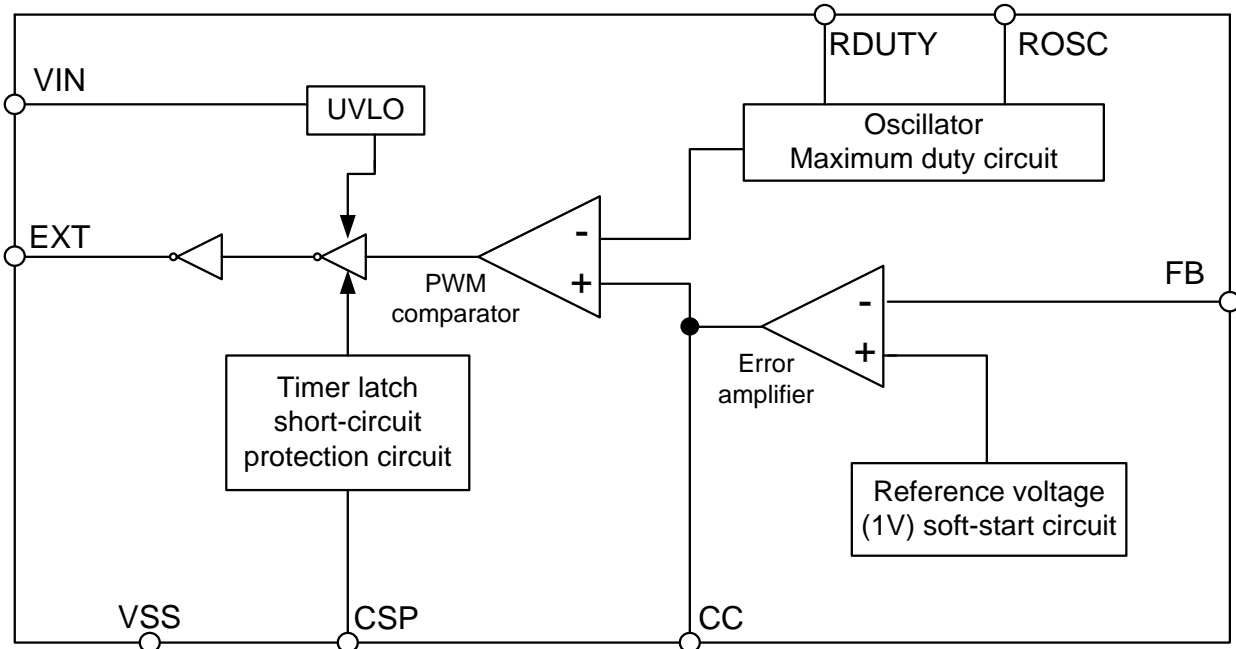

Figure 3. Block Diagram of FP6791C

Absolute Maximum Ratings

- Supply Voltage (V_{IN}) ----- -0.3V to + 6.5V
- FB pin voltage (V_{FB}) ----- -0.3V to + 6.5V
- EXT pin voltage (V_{EXT}) ----- -0.3V to + 6.5V
- CSP pin voltage (V_{CSP}) ----- -0.3V to + 6.5V
- CC pin voltage (V_{CC}) ----- -0.3V to + 6.5V
- CC pin current (I_{CC}) ----- $\pm 10\text{mA}$
- ROSC pin voltage (V_{ROSC}) ----- -0.3V to +6.5V
- ROSC pin current (I_{ROSC}) ----- $\pm 10\text{mA}$
- RDUTY pin voltage (V_{RDUTY}) ----- -0.3V to +6.5V
- RDUTY pin current (I_{RDUTY}) ----- $\pm 10\text{mA}$
- Storage temperature (T_{STG}) ----- -40°C to $+125^{\circ}\text{C}$
- Power dissipation ($T_A=+25^{\circ}\text{C}$), TSSOP-8 ----- $+560\text{mW}$
- Package Thermal Resistance, TSSOP-8 (θ_{JA}) ----- 180°C/W
- Junction Temperature ----- $+150^{\circ}\text{C}$
- Storage Temperature Range ----- -65°C to $+150^{\circ}\text{C}$
- Lead Temperature (Soldering, 10s) ----- $+260^{\circ}\text{C}$

Note 1 : Stresses beyond those listed under "Absolute Maximum Ratings" may cause permanent damage to the device.

Recommended Operating Conditions

- Supply Voltage (V_{IN}) ----- $+2.6\text{V}$ to $+6\text{V}$
- Operation Temperature Range (T_{OPR}) ----- -40°C to $+85^{\circ}\text{C}$

Electrical Characteristics

$V_{IN}=+5V$, $T_A=25^{\circ}C$, unless otherwise specified.

Parameter	Symbol	Conditions	Min	Typ	Max	Unit
Operating Input Voltage	V_{IN}		2.6	5	6	V
FB Voltage	V_{FB}		0.985	1	1.015	V
Current Consumption ($V_{IN}=3.3V$)	I_{SS1}	$F_{OSC} = 1.1MHz$; $V_{FB} = 0.95V$	-	700	900	μA
EXT Pin Output Current($V_{IN}=3.3V$)	I_{EXT}	$V_{EXT}=V_{IN} - 0.4V$		-100	-60	mA
	I_{EXT}	$V_{EXT}= 0.4V$	100	160		
FB Voltage Temperature Coefficient	$\Delta V_{FB} / \Delta T_a$	$T_a = -40^{\circ}C$ to $+85^{\circ}C$		100		ppm/ $^{\circ}C$
Oscillation Frequency	F_{OSC}	$R_{OSC}=120k\Omega$ (Note3)	1.02	1.133	1.246	MHz
Oscillation Frequency Temperature Coefficient (Note5)	$\Delta F_{OSC} / \Delta T_a$	$T_a = -40^{\circ}C$ to $+85^{\circ}C$ $F_{OSC} = 1.1MHz$		500		ppm/ $^{\circ}C$
Maximum Duty Cycle	Duty	$R_{DUTY}=100k\Omega$ (Note4)	80.6	84.9	94	%
Soft-Start Time	t_{SS}		15	20	30	ms
UVLO Detection Voltage	V_{UVLO}		2.09	2.2	2.31	V
UVLO Hysteresis	$V_{UVLOHYS}$		0.18	0.3	0.42	V
Short-circuit protection delay time	T_{PRO}	$C_{SP}=0.1\mu F$	33	50	75	ms
CC Pin Output Current	I_{CCH}	$V_{FB} = 2V$		50		μA
	I_{CCL}	$V_{FB} = 0V$		-50		
Timer Latch Reset Voltage	V_{RTLTL}		0.7	1	1.3	V

Note 2 : Specifications are production tested at $T_A=25^{\circ}C$. Specifications over the $-40^{\circ}C$ to $85^{\circ}C$ operating temperature range are guaranteed by design.

Note 3 : The recommend R_{OSC} value for setting oscillation frequency is ranging from $100k\Omega$ to $300k\Omega$ ($F_{OSC} = 500kHz$ to $1.3MHz$). The oscillation frequency is in the range of typical values when an ideal R_{OSC} is connected, so the fluctuation of the IC ($\pm 10\%$) must be considered.

Note 4 : The recommended R_{DUTY}/R_{OSC} ratio for setting the maximum duty is ranging from 0.5 to 3.2 (Max. Duty = 55% to 88.5%). The maximum duty is in the range of typical value when an ideal R_{DUTY} is connected, so the fluctuation of the IC ($\pm 5\%$) must be considered.

Note 5 : Guarantee by design.

Typical Performance Curves

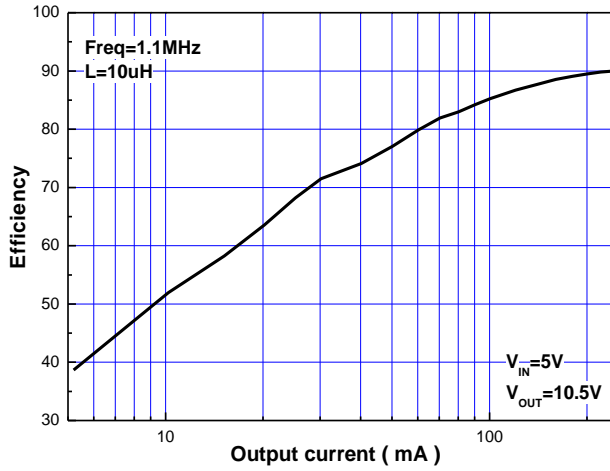

Figure 4. Efficiency vs. Output Current

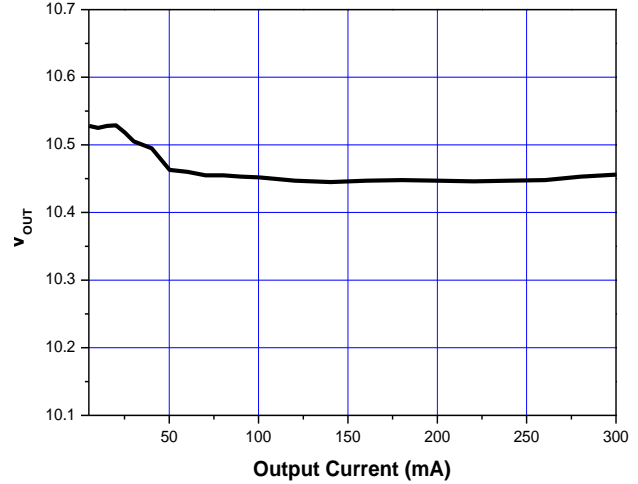

Figure 5. Output Voltage vs. Output Current

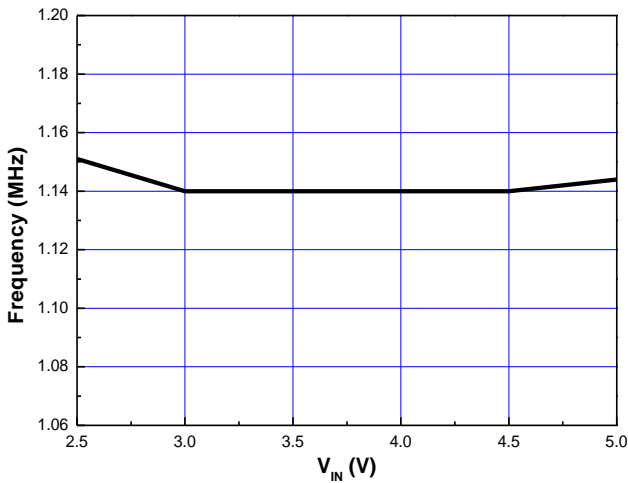

Figure 6. Frequency vs. Input Voltage

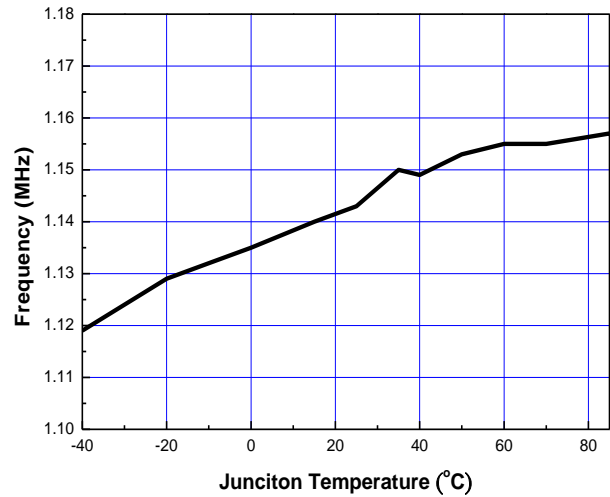

Figure 7. Frequency vs. Junction Temperature

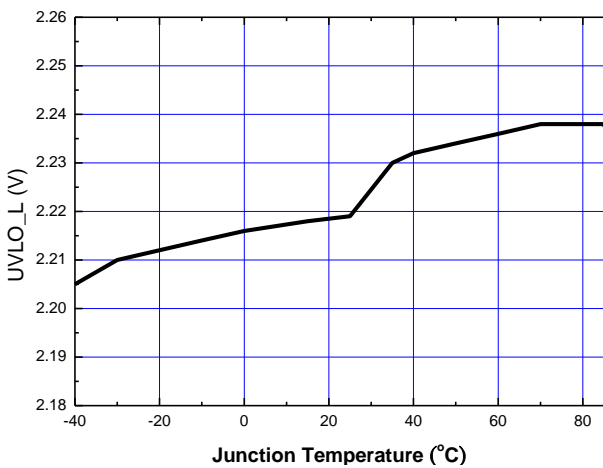

Figure 8. UVLO Low Level vs. Junction Temperature

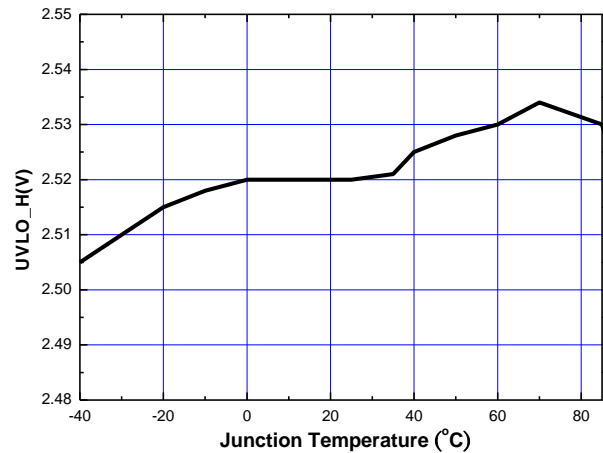

Figure 9. UVLO High Level vs. Junction Temperature

Typical Performance Curves (Continued)

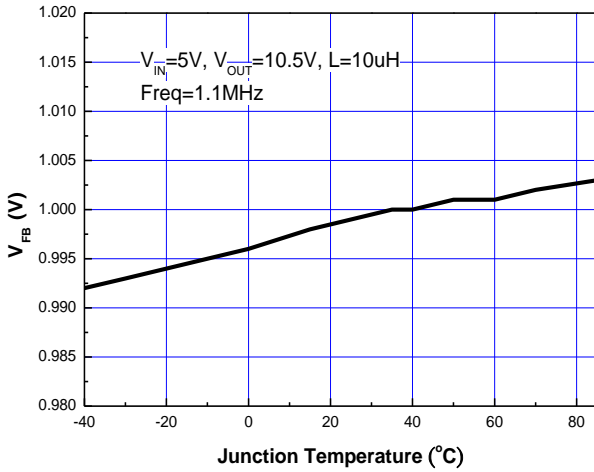
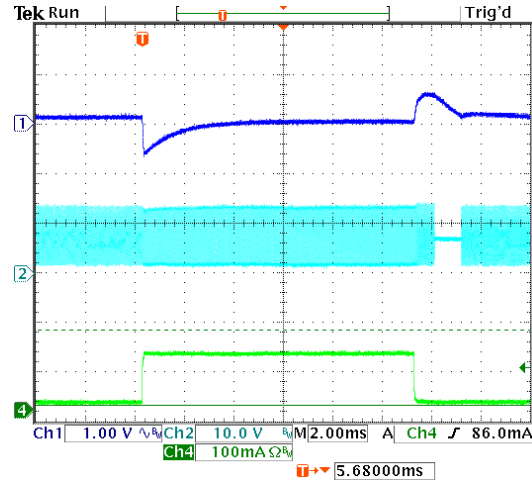
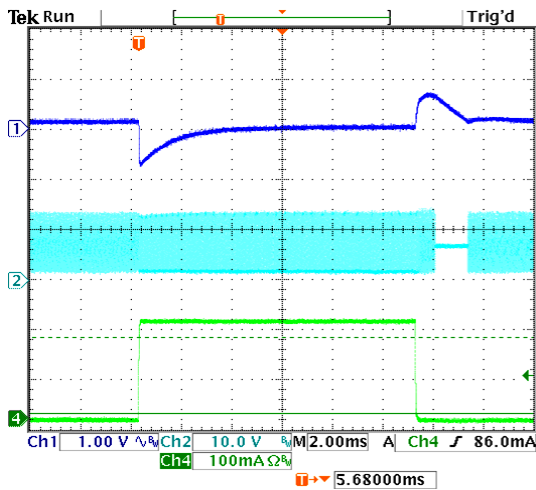

Figure 10. V_{FB} vs. Junction Temperature



CH1: Output Voltage, AC-Coupled
 CH2: Switch Point
 CH4: Loading Current
 $V_{IN}=5V$, $V_{OUT}=10.5V$, I_{LOAD} form 1mA to 100mA,
 $L=10\mu H$, $FREQ=1.1MHz$, $C_{OUT}=4.7\mu F*4+0.1\mu F*2$

Figure 11. Load transient Response



CH1: Output Voltage, AC-Coupled
 CH2: Switch Point
 CH4: Loading Current
 $V_{IN}=5V$, $V_{OUT}=10.5V$, I_{LOAD} form 1mA to 200mA,
 $L=10\mu H$, $FREQ=1.1MHz$, $C_{OUT}=4.7\mu F*4+0.1\mu F*2$

Figure 12. Load transient Response

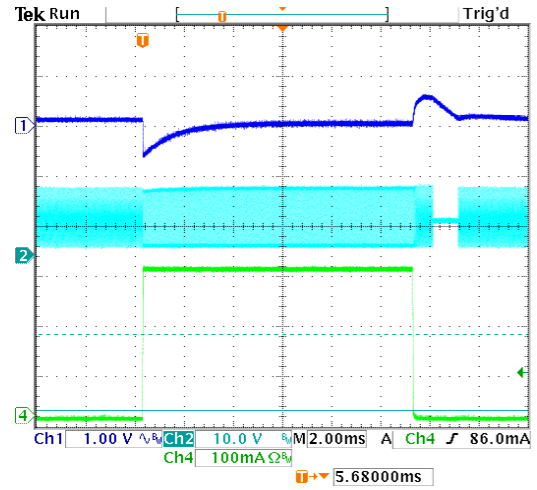

CH1: Output Voltage, AC-Coupled
 CH2: Switch Point
 CH4: Loading Current
 $V_{IN}=5V$, $V_{OUT}=10.5V$, I_{LOAD} form 1mA to 300mA,
 $L=10\mu H$, $FREQ=1.1MHz$, $C_{OUT}=4.7\mu F*4+0.1\mu F*2$

Figure 13. Load transient Response

Typical Performance Curves (Continued)

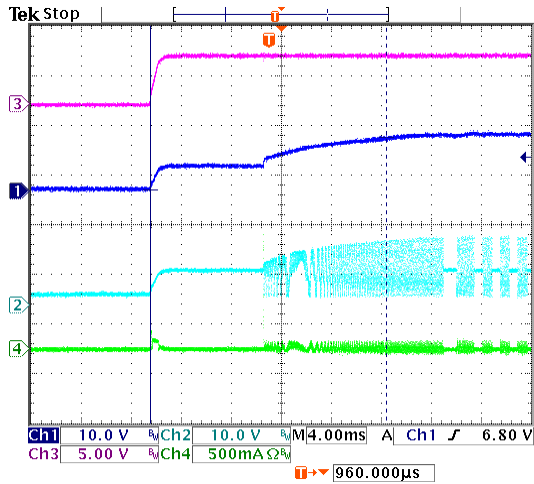

CH1: Output Voltage
CH2: Switch Point
CH3: VIN
CH4: Inductor Current
 $V_{IN}=5V, V_{OUT}=10.5V, L=10\mu H, I_{LOAD}=0mA,$
 $FREQ=1.1MHz, C_{OUT}=4.7\mu F*4+0.1\mu F*2$

Figure 14. Light Load Start-up Waveform

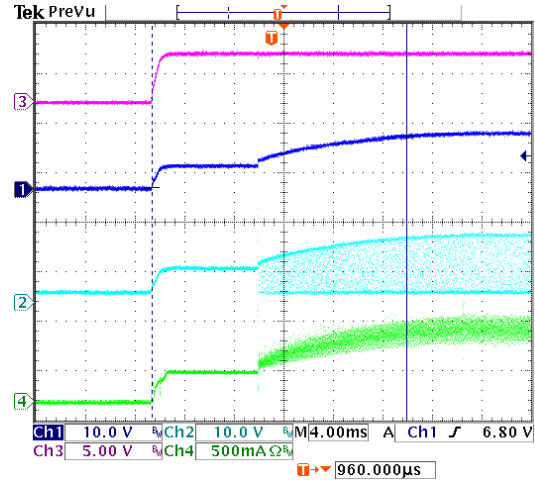

CH1: Output Voltage
CH2: Switch Point
CH3: VIN
CH4: Inductor Current
 $V_{IN}=5V, V_{OUT}=10.5V, L=10\mu H, FREQ=1.1MHz$
 $I_{LOAD}=300mA, C_{OUT}=4.7\mu F*4+0.1\mu F*2$

Figure 15. Heavy Load Start-up Waveform

Applications Information

PWM Voltage Mode Converter

The FP6791C is a CMOS step-up converter using a pulse width modulation method (PWM). The maximum duty ratio of FP6791C can be controlled by the resistor connected to the RDUTY pin. The converter can operate in both discontinuous conduction mode (DCM) and continuous conduction mode (CCM). The FP6791C operation can be best understood by referring to the block diagram in Figure 3. The error amplifier monitors the output voltage via the feedback resistor divider by comparing the feedback voltage with the reference voltage. When the feedback voltage is lower than the reference voltage, the error amplifier output will increase. The error amplifier output is then compared with the oscillator ramp voltage at the PWM controller. When the error amplifier output voltage is higher than ramp, the EXT pin turns on the external transistor, the output voltage will increase, and vice versa. As the feedback voltage is higher than the reference voltage, the error amplifier output will decrease. When the error amplifier output voltage is lower than ramp, the EXT pin turns off the external transistor, the output voltage will decrease.

Soft Start

The FP6791C includes internal 20mS (Typ.) soft start function. The soft start function can minimize the inrush current. When power is on, a constant current will charge an internal capacitor. When power is off, the internal capacitor will be discharge for next soft start time.

Output Voltage Setting

With the FP6791C, the output voltage can be set value by external divider network. An external resistor divider is required to divide the output voltage down to the nominal reference voltage. As shown in Figure 2, the resistor divider output feeds to the FB pin, which connects to the inverting input of the error amplifier. The non-inverting input of the error amplifier is connected to a 1V (Typ.) reference voltage. The following equation can be used to calculate the R_{FB1} and R_{FB2} value.

$$V_{OUT} = \left(1 + \frac{R_{FB1}}{R_{FB2}}\right) \times V_{FB}$$

Under Voltage Lockout

The under voltage lockout (UVLO) comparator has two voltage references, the start and stop thresholds. During power up, the UVLO comparator stop EXT pin switching and the external FET is held in the off status until the VIN reaches UVLO detection voltage. During VIN power down, the UVLO comparator allows the EXT pin switching until the UVLO stop threshold is reached. The UVLO function can prevent the IC form malfunction due to a transient status when power is applied or a momentary drop of the power supply voltage.

Short Circuit Protection

The short circuit protection function will stop switching when output voltage drops due to output short. The capacitor which connected to the CSP pin is used to set delay time of short circuit protection. If the maximum duty condition continues because of short circuit, the capacitor externally connected to the CSP pin will be charged, and EXT pin will stop switching after CSP pin voltage rises above the reference voltage. Than FP6791C latches off until input voltage is re-started.

Compensation

The compensation circuit is designed to guarantee stability over the full input/output voltage and full output load range. The compensation circuit can prevent excessive output ripple and unstable operation from deteriorating the efficiency. The compensation is implemented by connecting R_z and C_z series network between VSS pin and CC pin. R_z sets the high frequency gain for a high speed transient response. C_z sets the pole and zero of the error amplifier and keeps the system stable. Adjust R_z and C_z , taking into consideration conditions such as the inductor, output, and load current, so that optimum transient characteristics can be obtained.

Applications Information (Continued)

Oscillation Frequency Setting

The oscillation of FP6791C can be set in a range of 500kHz to 1.3MHz ($R_{OSC}=100k\Omega$ to $300k\Omega$) by using external resistor which connects to ROOSC pin. Select the resistor by Figure 16.

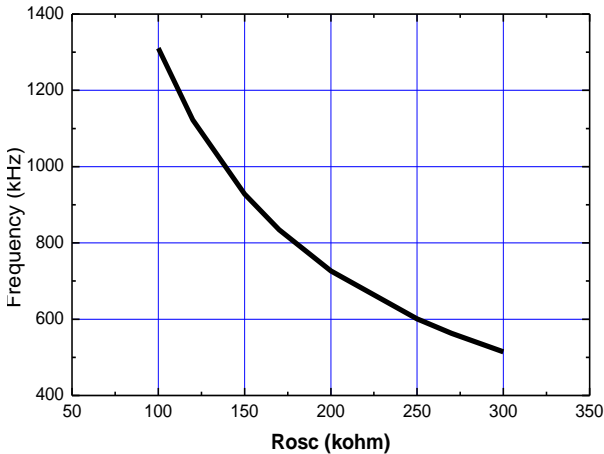

Figure 16. Rosc vs. Frequency

Maximum Duty Ratio Setting

The maximum duty of FP6791C can be set in a range of 55% to 88.5% by an external resistor which connects to RDUTY pin. The ratio of R_{DUTY}/R_{OSC} must range from 0.5 to 3.2 and R_{OSC} conform to range between $100k\Omega$ to $300k\Omega$. Select the resistor by referring to Figure 17.

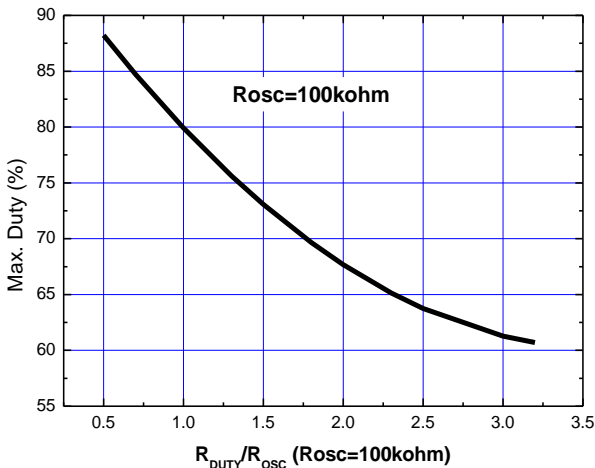

Figure 17. R_{DUTY}/R_{OSC} vs. Max. Duty

Inductor selection

The inductor selection depends on the switching frequency and current ripple by the following formula:

$$L \geq \frac{V_{IN}}{f_{OSC} \times \Delta I_L} \left(1 - \frac{V_{IN}}{V_{OUT}} \right)$$

Where f_{OSC} is switching frequency of the FP6791C

*The switching frequency of the FP6791C ranges between 500kHz and 1.3MHz. The switching frequency can be set value by external resistor.

Although small physical size and high efficiency are major concerns, the inductor should have low core losses and series resistance (DCR, copper wire resistance). The minimum inductor value, peak current rating and series resistance will affect the converter efficiency, maximum output load capability, transient response time and output voltage ripple. The inductor selection depends on input voltage, output voltage and maximum output current. Very high inductor minimize the current ripple and therefore reduce the peak current, which decreases core losses in the inductor and conduct losses in the entire power path. However, large inductor values also require more energy storage and more turns of wire. The size of inductor will become bigger and increase conduct losses. Low inductor values decrease the size but increase the current ripple and the peak current. Choose the inductor values based on the application. In addition, it is important to ensure the inductor saturation current exceeds the peak value of inductor current in application to prevent core saturation. Calculating the ripple current at operation point and the peak current required for the inductor :

$$\Delta I_L = \frac{V_{IN(MIN)} \times (V_{OUT} - V_{IN(MIN)})}{L \times V_{OUT} \times f_{OSC}}$$

$$I_{L(MAX)} = I_{IN(DC,MAX)} + \frac{\Delta I_L}{2}$$

$$= I_{IN(DC,MAX)} + \frac{V_{IN}}{2 \times f_{OSC} \times L} \left(1 - \frac{V_{IN(MIN)}}{V_{OUT}} \right)$$

$$= \frac{I_{OUT(MAX)} \times V_{OUT}}{\eta \times V_{IN(MIN)}} + \frac{V_{IN}}{2 \times f_{OSC} \times L} \left(1 - \frac{V_{IN(MIN)}}{V_{OUT}} \right)$$

Applications Information (Continued)

Where η =expected efficiency at that operating point. The value can be taken from an appropriate curve in the typical operating characteristics. ΔI_L =inductor ripple current, $I_{L(MAX)}$ =inductor peak current. In addition, the following equation used here assumes a constant K, which is the ratio of the inductor peak-to-peak AC current to average DV inductor current. A good compromise between the size of the inductor versus loss and output ripple is to choose a K 0.3 to 0.5. The peak inductor current is given by :

$$\Delta I_L = \frac{I_{OUT(MAX)} \times V_{OUT}}{\eta \times V_{IN(MIN)}} \left(1 + \frac{K}{2}\right)$$

Where K=ratio of the inductor peak-to-peak AC current to average DC inductor current, ΔI_L =inductor ripple current.

The inductor value is then given by:

$$L = \frac{V_{IN(MIN)}^2 \times \eta \times D}{K \times f_{OSC} \times V_{OUT} \times I_{OUT(MAX)}}$$

Where

$$D = \text{Duty cycle} = \frac{V_{IN(MIN)} - (V_F + V_{OUT})}{I_{IN(MAX)} \times R_{ds(on)} - (V_F + V_{OUT})}$$

V_F = Catch diode forward drop

f = Switching frequency

The inductor's saturation current rating should exceed $I_{L(MAX)}$ and the inductor DC current rating should exceed $I_{IN(DC,MAX)}$.

Rectifier diode selection

The diode is the largest source of loss in DC-DC converters. A high speed diode is necessary due to the high switching frequency. The Schottky diodes are recommended because of their fast recovery time and low forward drop voltage for better efficiency. The forward drop voltage of the Schottky diode will result in the conduction losses in the diode, and the diode capacitance will cause the switching losses. Therefore, it is necessary to consider both forward voltage drop and diode capacitance for diode selection. In addition, the reverse voltage rating of this diode should 1.3 times of the maximum output voltage. The rectifier diode must meet the output and peak inductor current requirement.

Output Capacitor Selection

The capacitor on the output side (C_{OUT}) is used for sustaining the output voltage when the external MOSFET or diode is switched on and smoothing the ripple voltage. Select an appropriate capacitance value based on the load condition. For lower output voltage ripple, the low ESR ceramic capacitor is recommended. The output voltage ripple consists of two components. One is the pulsating output ripple current through ESR, and the other is the capacitive ripple caused by charging and discharging.

$$\Delta V_O = V_{RIPPLE_ESR} + V_{RIPPLE_C}$$

$$\cong \Delta I_L \times R_{ESR} + \frac{\Delta I_L}{C_{OUT}} \left(\frac{V_{OUT} - V_{IN}}{V_{OUT} \times f_{OSC}} \right)$$

Where ΔV_O =output voltage ripple, ΔI_L =inductor ripple current, $I_{L(MAX)}$ = inductor peak current.

The optimal capacitor differs depending on the inductor value, wiring, and application (output load), so select the capacitor after performing sufficient evaluation under the actual usage condition.

Input Capacitor Selection

The capacitor on input side (C_{IN}) can stabilize the input voltage and minimize peak current ripple from the power source for better efficiency. The value of the capacitor depends on the impedance of the input source used. For better input bypassing, low ESR ceramic capacitor is recommended for better performance.

External Switch Transistor

An enhancement N-channel MOSFET or a bipolar NPN transistor can be used as the external switch transistor. For high efficiency, it's ideal to use a MOSFET with a low R_{DS-ON} and small input capacitance. It is a more efficient switch than a bipolar NPN transistor. The R_{DS-ON} and input capacitance generally share a trade-off relationship. The R_{DS-ON} is efficient in a range which the output current is relatively great during low frequency switching, and the input capacitance is efficient in a range which the output current is middling during high frequency switching.

Applications Information (Continued)

Select a MOSFET whose R_{DS-ON} and input capacitance are optimal depending on the usage conditions. The input voltage is supplied for the gate voltage of the MOSFET, so select a MOSFET with a gate withstanding voltage that is equal to maximum usage value of the input voltage or higher and drain withstanding voltage that is equal to the output voltage and diode voltage or higher. An enhancement N-channel MOSFET can be selected by the following guidelines:

1. Low R_{DS-ON} .
2. Low gate threshold voltage.
3. Rated continuous drain current should be larger than the peak inductor current.
4. Low gate capacitance.

If a MOSFET with a threshold near the UVLO detection voltage is used, a large current may flow and stop the output voltage from rising and possibly generating heat in the worst case. Select a MOSFET with a threshold that is sufficiently lower than the UVLO detection voltage value.

Feed-forward Capacitor Selection

The feed-forward capacitor (C_F) is used to improve the performance of internally compensated DC-DC converter. To optimize transient response, a feed-forward capacitor value is chosen such that the gain and phase of the feedback increases the bandwidth of the converter, while still maintaining an acceptable phase margin. In general, capacitor causes the loop gain to crossover too high in frequency and the feed-forward capacitor phase contribution is insufficient, resulting in unacceptable phase margin or instability. The following process outlines a step by step procedure for optimizing the feed-forward capacitor.

Determine the crossover frequency of converter.

Once the crossover frequency is known, the equation allows calculation of feed-forward capacitor value which prompts a good compromise between bandwidth improvement and acceptable phase margin.

The feed-forward capacitor is selected by the following formula:

$$C_{FB} = \frac{1}{2\pi \times f_{crossover}} \times \sqrt{\frac{1}{R_{FB1}} \times \left(\frac{1}{R_{FB1}} + \frac{1}{R_{FB2}} \right)}$$

Layout Recommendation

For high frequency switching power supplies, the device's performance including efficiency, output noise, transient response and control loop stability are dramatically affected by PCB layout.

There are some general guidelines for layout:

1. Place the external power components (the input capacitors, output capacitors, inductor and diode, etc.) in close proximity to the device. The traces which connect to these components should be as short and wide as possible to minimize parasitic inductance and resistance.
2. Place output capacitor next to Schottky diode as possible.
3. Place input capacitor close to the VIN pin.
4. The input and output capacitors' ground should be wide and short enough to connect to a ground plane.
5. The feedback network should sense the output voltage directly from the point of load, and be as far away from noisy loop as possible.
6. The compensation circuit should be away from the power loops and should be shielded with a ground trace to prevent noise coupling.
7. Place the resistor close to RDUTY and ROSC pin.

Outline Information

TSSOP-8 Package (Unit: mm)

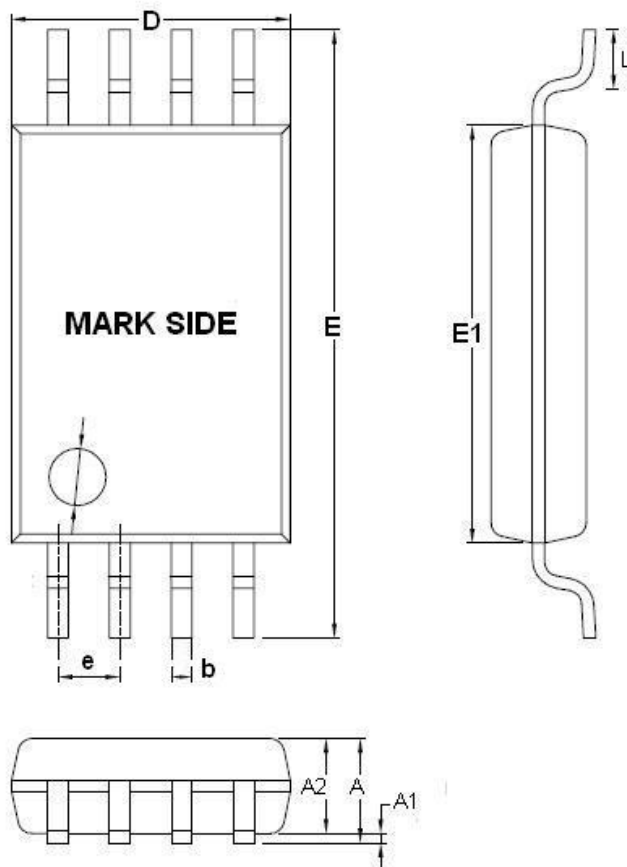

SYMBOLS UNIT	DIMENSION IN MILLIMETER	
	MIN	MAX
A	0.80	1.20
A1	0.00	0.15
A2	0.80	1.05
b	0.19	0.30
D	2.90	3.10
E	6.20	6.60
E1	4.30	4.50
e	0.55	0.75
L	0.45	0.75

Note : Followed from JEDEC MO-153-F.

Carrier dimensions

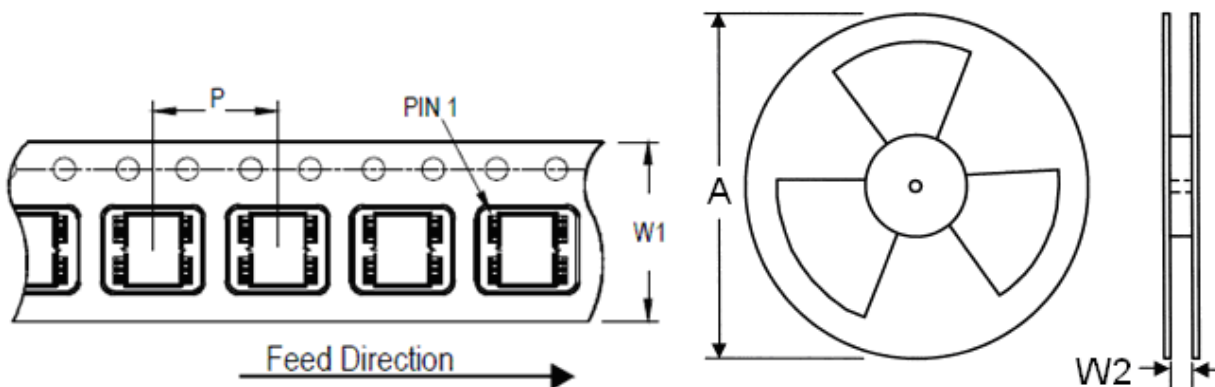

Tape Size (W1) mm	Pocket Pitch (P) mm	Reel Size (A)		Reel Width (W2) mm	Empty Cavity Length mm	Units per Reel
		in	mm			
12	8	13	330	12.4	400~1000	2,500

Life Support Policy

Fitipower's products are not authorized for use as critical components in life support devices or other medical systems.