

Microprocessor Reset Circuits With Adjustable Delay Time

Description

The FP6801 asserts a reset signal whenever the V_{DD} supply voltage declines below a preset threshold. The reset threshold voltage is fixed internally with an accuracy of $\pm 2.0\%$. A time delayed reset can be accomplished with the addition of an external capacitor.

The output reset signal is set to be active low. That means when the power supply voltage is lower than reset threshold, the OUT pin will turn low.

FP6801 has two different output forms, CMOS output and N-channel open-drain output. It is available in space-saving SOT-23-5 and SC-82 packages.

Features

- Precision Monitoring of 2.5V, 3.0V, 3.3V and 5.0V Power Supply Voltages
- Ultra-Low Supply Current at 2.5 μ A Typ.
- Operating Voltage Range from 1V to 5.5V
- $\pm 2.0\%$ Reset Threshold Accuracy
- Reset Threshold Hysteresis: 5% Typ.
- Active Low Output
- Adjustable Delay Time
- Small Package: SOT-23-5 and SC-82
- RoHS Compliant

Applications

- TFT-LCD Panel
- Battery Powered Equipment
- Microprocessor Power Supply Monitoring
- Embedded System
- Automotive

Pin Assignments

S5 Package (SOT-23-5)

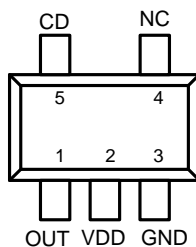

C8 Package (SC-82)

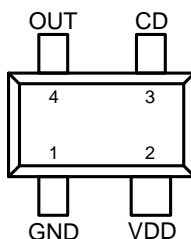

Ordering Information

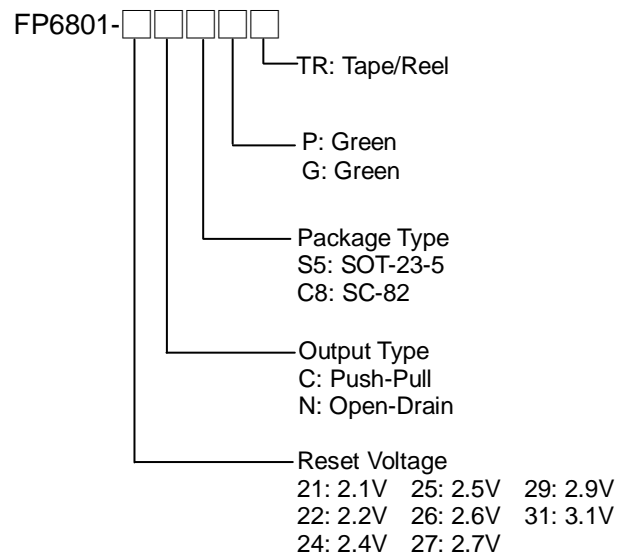

Figure 1. Pin Assignment of FP6801

SOT-23-5 Marking

Part Number	Product Code	Part Number	Product Code
FP6801-21CS5P	Gf	FP6801-21NS5P	Gh
FP6801-21CS5G	Gf =	FP6801-21NS5G	Gh=
FP6801-22CS5P	Ga	FP6801-22NS5P	Gk
FP6801-22CS5G	Ga=	FP6801-22NS5G	Gk=
FP6801-24CS5P	GZ	FP6801-24NS5P	G1
FP6801-24CS5G	GZ=	FP6801-24NS5G	G1=
FP6801-25CS5P	GA	FP6801-25NS5P	GB
FP6801-25CS5G	GA=	FP6801-25NS5G	GB=
FP6801-26CS5P	Gb	FP6801-26NS5P	Gm
FP6801-26CS5G	Gb=	FP6801-26NS5G	Gm=
FP6801-27CS5P	G0	FP6801-27NS5P	G2
FP6801-27CS5G	G0=	FP6801-27NS5G	G2=
FP6801-29CS5P	Gd	FP6801-29NS5P	Gn
FP6801-29CS5G	Gd=	FP6801-29NS5G	Gn=
FP6801-31CS5P	Ge	FP6801-31NS5P	Gr
FP6801-31CS5G	Ge=	FP6801-31NS5G	Gr=

SC-82 Marking

Part Number	Product Code	Part Number	Product Code
FP6801-21CC8P	Gi	FP6801-21NC8P	Gs
FP6801-21CC8G	Gi=	FP6801-21NC8G	Gs=
FP6801-22CC8P	Gv	FP6801-22NC8P	GD
FP6801-22CC8G	Gv=	FP6801-22NC8G	GD=
FP6801-24CC8P	G3	FP6801-24NC8P	G5
FP6801-24CC8G	G3=	FP6801-24NC8G	G5=
FP6801-26CC8P	Gw	FP6801-26NC8P	GE
FP6801-26CC8G	Gw=	FP6801-26NC8G	GE=
FP6801-27CC8P	G4	FP6801-27NC8P	G6
FP6801-27CC8G	G4=	FP6801-27NC8G	G6=
FP6801-29CC8P	Gx	FP6801-29NC8P	GF
FP6801-29CC8G	Gx=	FP6801-29NC8G	GF=
FP6801-31CC8P	Gz	FP6801-31NC8P	GG
FP6801-31CC8G	Gz=	FP6801-31NC8G	GG=

Typical Application Circuit

Figure 2. Typical Application Circuit of FP6801

Functional Pin Description

Pin Name	Pin Function
GND	Ground.
CD	Connect capacitor to adjust OUT delay time.
OUT	When the power supply voltage is lower than the reset threshold, the OUT will be low.
VDD	Supply Voltage.

Block Diagram

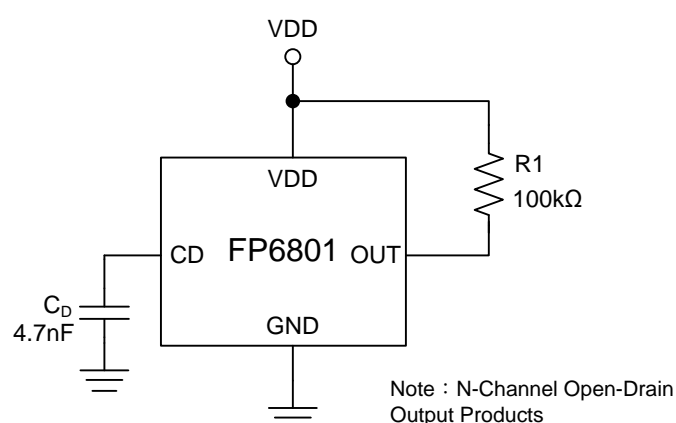
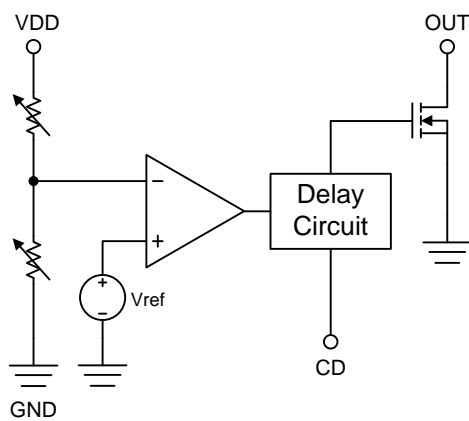

Figure 3. N-Channel Open-Drain Output Products

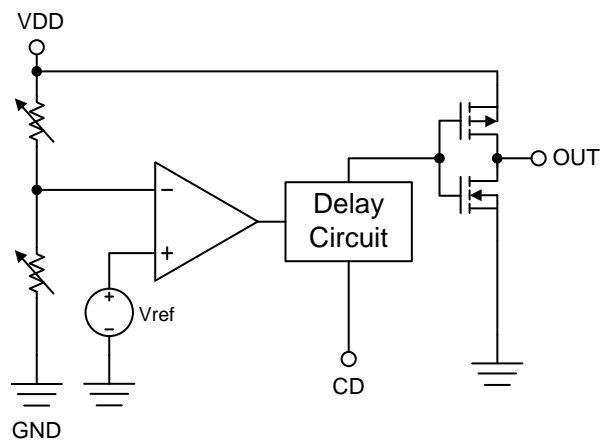

Figure 4. CMOS Output Products

Absolute Maximum Ratings

- Supply Voltage (V_{DD} to GND) ----- -0.3V to +6V
- OUT voltage (Push-Pull) ----- -0.3 to ($V_{DD} + 0.3V$)
- OUT Voltage (Open Drain) ----- -0.3 to ($V_{DD} + 0.3V$)
- Output Current ----- +20mA
- Power Dissipation, P_D @ $T_A=25^\circ C$
 - SOT-23-5 ----- +400mW
 - SC-82 ----- +200mW
- Package Thermal Resistance, (θ_{JA})
 - SOT-23-5 ----- +250°C/W
 - SC-82 ----- +500°C/W
- Maximum Junction Temperature ----- +150°C
- Storage Temperature Range (T_{STG}) ----- -65°C to +150°C
- Lead Temperature (Soldering, 10sec.) ----- +260°C

Note1 : Stresses beyond those listed under "Absolute Maximum Ratings" may cause permanent damage to the device.

Recommended Operating Conditions

- Supply Voltage (V_{DD} to GND) ----- +1.0V to +5.5V
- Operation Temperature Range ----- -40°C to +85°C

Electrical Characteristics

($V_{DD}=5V$, $T_A=25^{\circ}C$, unless otherwise specified.)

Parameter	Symbol	Conditions	Min	Typ.	Max	Unit
V_{DD} Range	V_{DD}		1.0		5.5	V
Supply Current	I_{DD}	$-V_{TH} < 3.3V$, $V_{DD} = 3.6V$		2.5	5	μA
		$3.3V < -V_{TH} < 4.7V$, $V_{DD} = 5V$		2.5	5	
Reset Threshold	$-V_{TH}$		$0.98 \times (-V_{TH})$	$-V_{TH}$	$1.02 \times (-V_{TH})$	V
Hysteresis Width	V_{HYS}		3%	5%	7%	
Reset Threshold Temperature Coefficient (Note2)				50		ppm/ $^{\circ}C$
Delay Time	T_D	$C_D = 4.7nF$, $-V_{TH} < 3.3V$, $V_{DD} = 3.6V$	20	27	34	ms
		$C_D = 4.7nF$, $3.3V < -V_{TH} < 4.7V$, $V_{DD} = 5V$				
Output Current	I_{OUT}	NCH, $V_{DD} = 2.2V$, $V_{DS} = 0.5V$	5	10		mA
		PCH, $V_{DD} = 4.8V$, $V_{DS} = 0.5V$	3	6		

Note 2 : Guarantee by design.

Typical Performance Curves

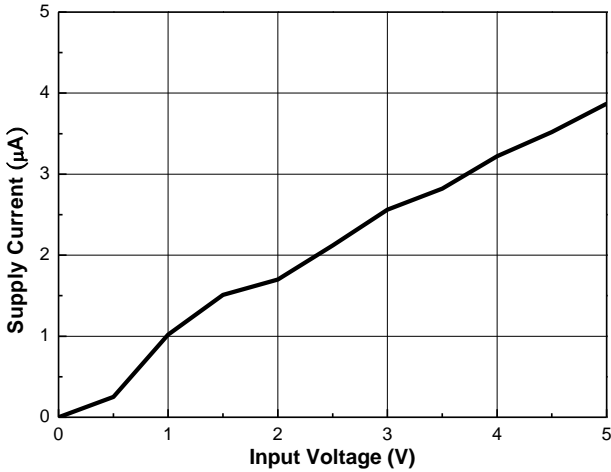

Figure 5. Supply Current Consumption (I_{DD}) vs. Input Voltage (V_{DD}) for $-V_{TH}=2.4V$

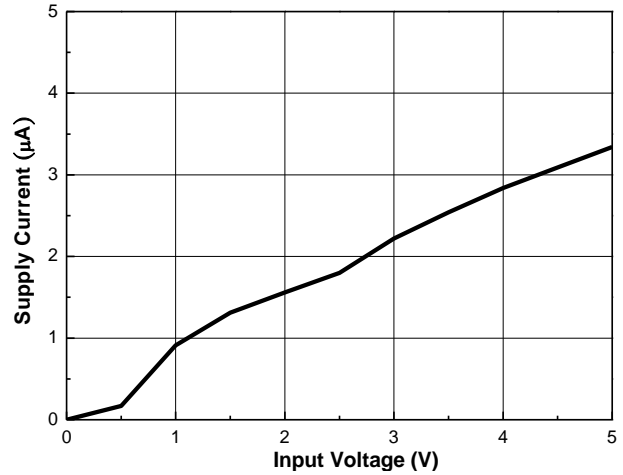

Figure 6. Supply Current Consumption (I_{DD}) vs. Input Voltage (V_{DD}) for $-V_{TH}=2.7V$

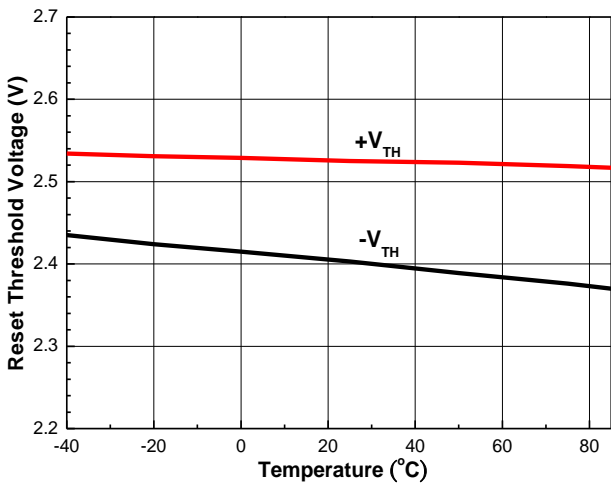

Figure 7. Reset Threshold Voltage ($\pm V_{TH}$) vs. Temperature (T_a) for $-V_{TH}=2.4V$

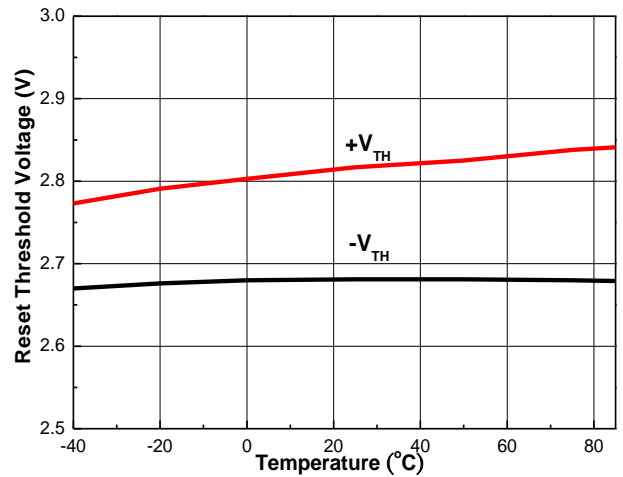

Figure 8. Reset Threshold Voltage ($\pm V_{TH}$) vs. Temperature (T_a) for $-V_{TH}=2.7V$

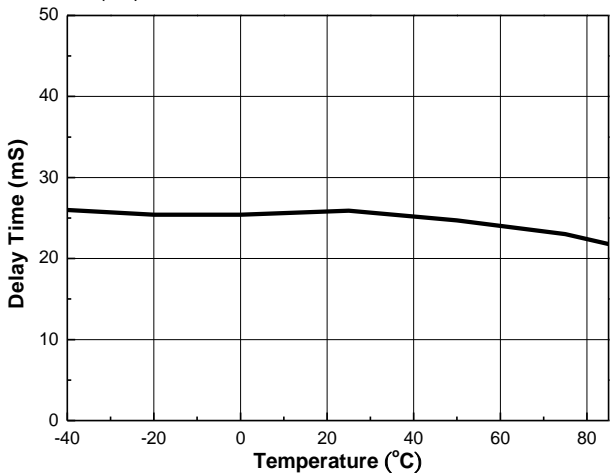

Figure 9. Delay Time (T_D) vs. Temperature for $-V_{TH}=2.2V$, $C_D=4.7nF$

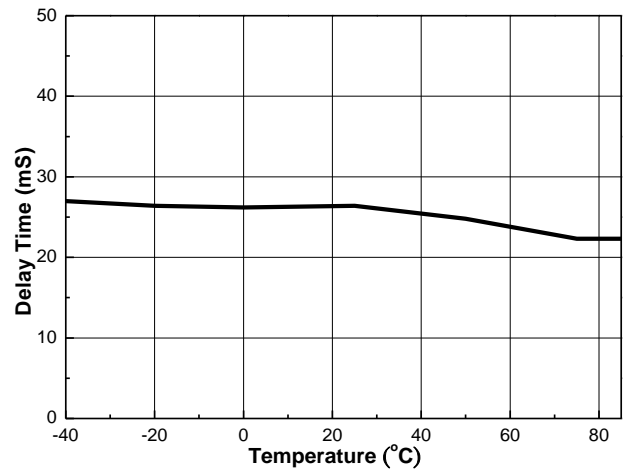

Figure 10. Delay Time (T_D) vs. Temperature for $-V_{TH}=2.7V$, $C_D=4.7nF$

Typical Performance Curves (Continued)

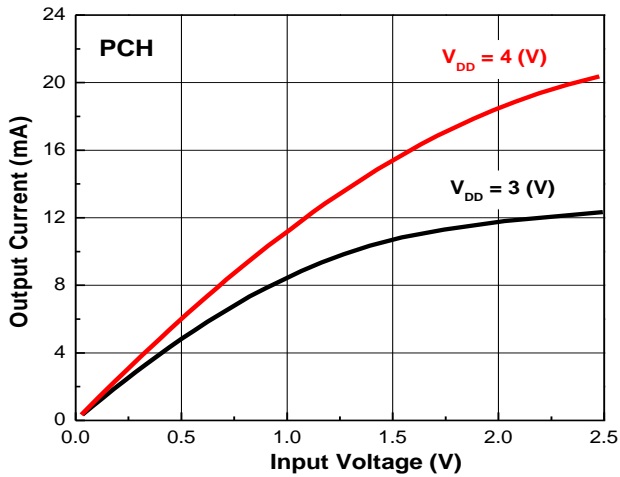

Figure 11. PCH Output Current (I_D) Capability for $-V_{TH}=2.7V$

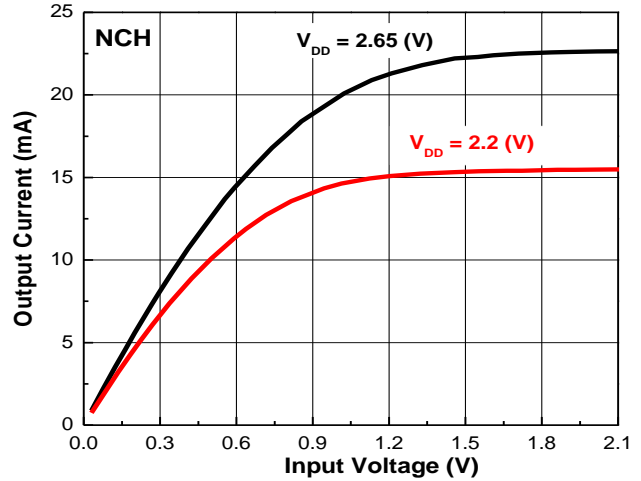

Figure 12. NCH Output Current (I_D) Capability for $-V_{TH}=2.7V$

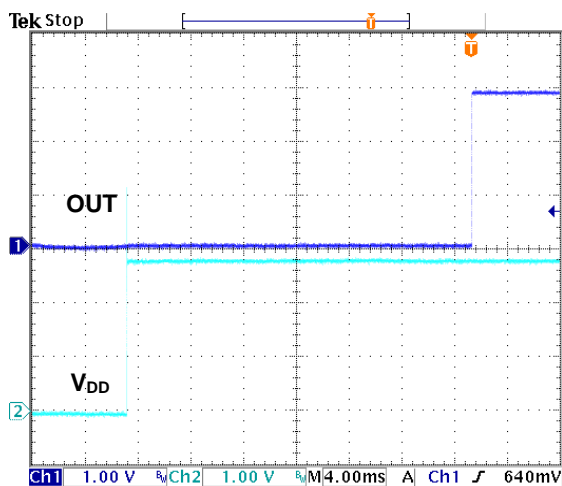

Figure 13. Power-Up OUT Timeout Waveforms for $-V_{TH}=2.7V$

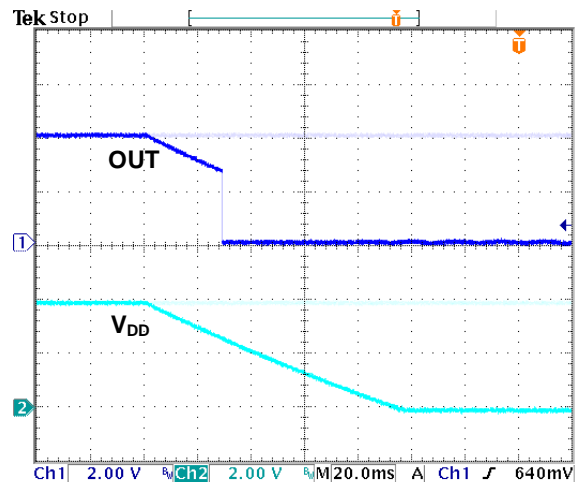

Figure 14. Power-Down OUT Timeout Waveforms for $-V_{TH}=2.7V$

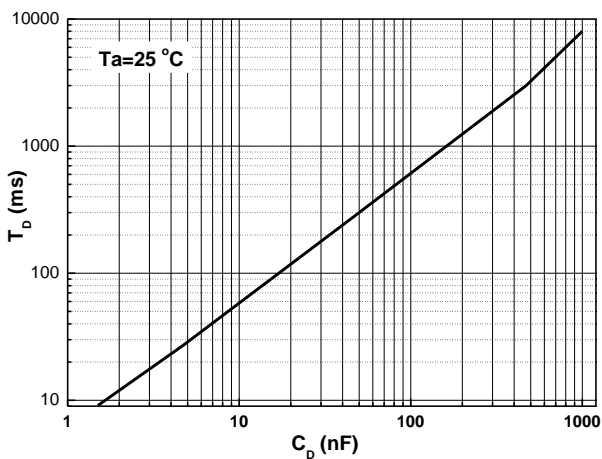
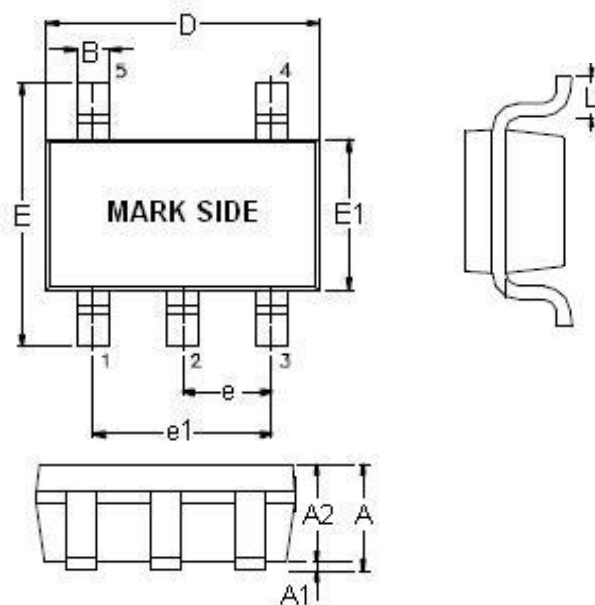

Figure 15. Delay Time(T_D) vs. Capacitance (C_D) for $-V_{TH}=2.7V$

Outline Information

SOT-23-5 Package (Unit: mm)



SYMBOLS UNIT	DIMENSION IN MILLIMETER	
	MIN	MAX
A	0.90	1.45
A1	0.00	0.15
A2	0.90	1.30
B	0.30	0.50
D	2.80	3.00
E	2.60	3.00
E1	1.50	1.70
e	0.90	1.00
e1	1.80	2.00
L	0.30	0.60

Note : Followed From JEDEC MO-178-C.

Carrier Dimensions

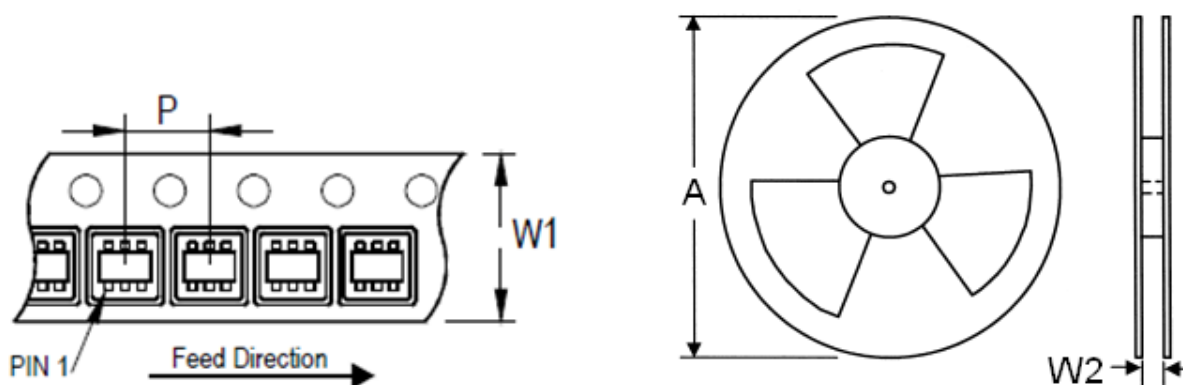

Tape Size (W1) mm	Pocket Pitch (P) mm	Reel Size (A)		Reel Width (W2) mm	Empty Cavity Length mm	Units per Reel
		in	mm			
8	4	7	180	8.4	300~1000	3,000

Outline Information (Continued)

SC-82 Package (Unit: mm)

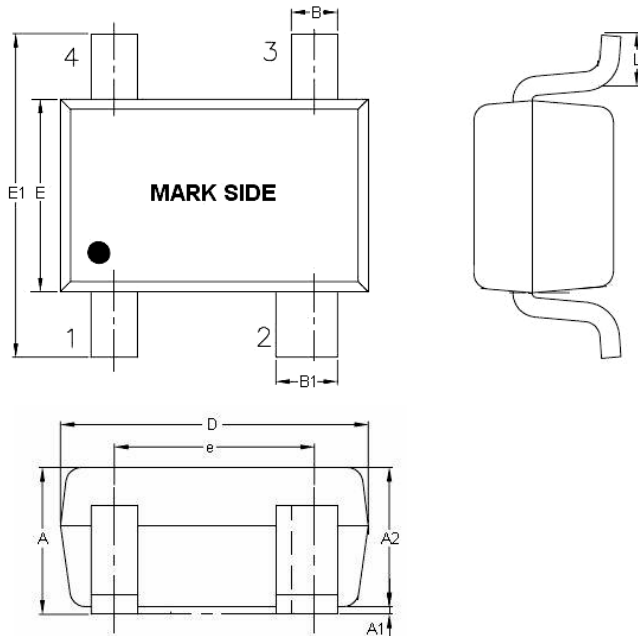

SYMBOLS UNIT	DIMENSION IN MILLIMETER	
	MIN	MAX
A	0.80	1.10
A1	0.00	0.10
A2	0.80	1.00
B	0.15	0.40
B1	0.35	0.50
D	1.80	2.20
E	1.15	1.35
E1	1.80	2.40
e	1.20	1.40
L	0.25	0.45

Carrier Dimensions

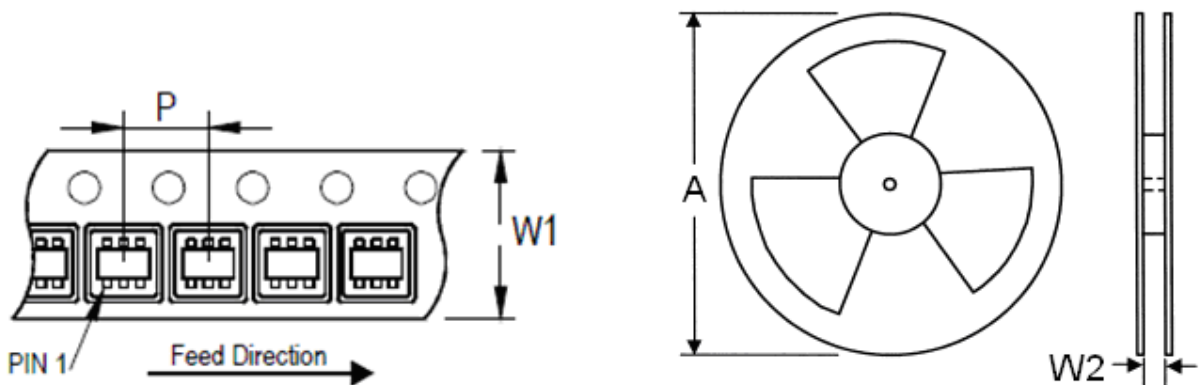

Tape Size (W1) mm	Pocket Pitch (P) mm	Reel Size (A)		Reel Width (W2) mm	Empty Cavity Length mm	Units per Reel
		in	mm			
8	4	7	180	8.4	300~1000	3,000

Life Support Policy

Fitipower's products are not authorized for use as critical components in life support devices or other medical systems.