

## 23V, 1.2A, 600KHz Asynchronous Step-Down DC/DC Converter

### Description

The FR97063 is a monolithic step-down switch mode converter with a built-in power MOSFET. It achieves 1.2A output current over a wide input supply range with excellent load and line regulation. Current mode operation provides fast transient response and eases loop stabilization. Fault condition protection includes cycle-by-cycle current limit and thermal shutdown.

The FR97063 is available in SOP-8 package, which provides a very compact system solution and good thermal conductance.

### Features

- 1.2A Output Current
- 250mΩ Internal Power MOSFET Switch
- Stable with Low ESR Output Ceramic Capacitors
- Up to 90% Efficiency
- Fixed 600KHz Frequency
- Current Mode Operation
- Thermal Shutdown
- Cycle-by-Cycle Over Current Protection
- Wide 4.5V to 23V Operating Input Range
- Output Adjustable from 0.805V to 15V
- 10μA Shutdown Current
- Available in SOP-8 Package

### Applications

- Distributed Power System
- Battery Charger
- OLPC, Netbook
- Pre-Regulator for Linear Regulator
- WLED Driver

### Pin Assignments

SO Package (SOP-8)

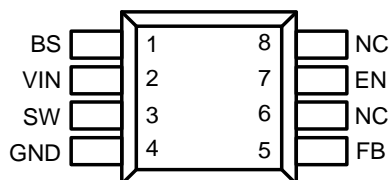
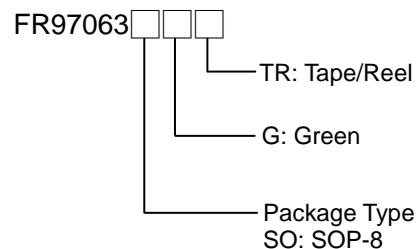

Figure 1. Pin Assignment of FR97063

### Ordering Information



## Typical Application Circuit

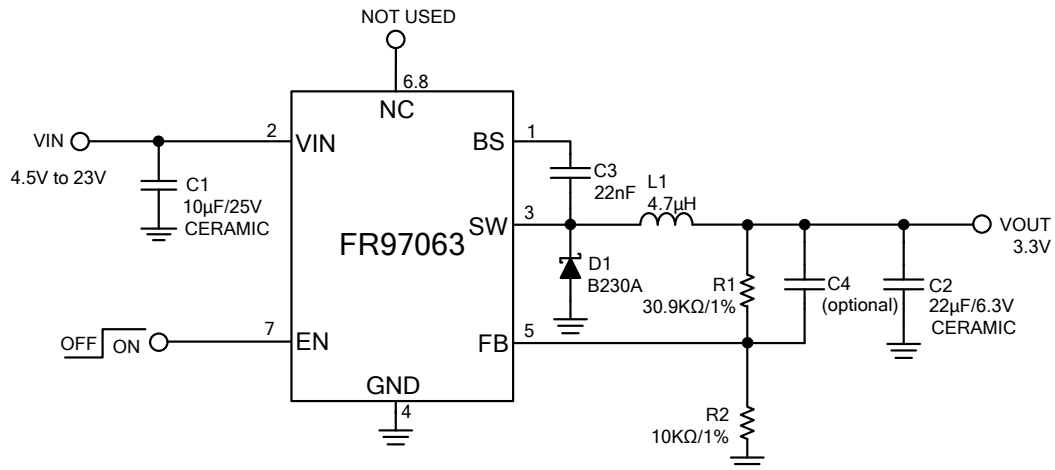

Figure 2. Output 3.3V Application Circuit

## Functional Pin Description

Pin Name	Pin No.	Pin Function
<b>BS</b>	1	Bootstrap. A 22nF capacitor is connected between SW and BS pins to drive the power switch's gate above the supply voltage.
<b>VIN</b>	2	Power Supply Input. Drive 4.5V~23V voltage to this pin to power on this chip. Connect a 10µF ceramic bypass capacitor between VIN and GND to eliminate noise.
<b>SW</b>	3	Switch Output. Connect this pin to the switching end of the inductor.
<b>GND</b>	4	Ground. This pin is the voltage reference for the regulated output voltage. For this reason, care must be taken in its layout.
<b>FB</b>	5	Feedback. An external resistor divider from the output to GND, tapped to the FB pin sets the output voltage.
<b>NC</b>	6, 8	No Connection.
<b>EN</b>	7	On/Off Control Input. Pull EN above 1.2V and below 5V to turn the device on.

**Block Diagram**

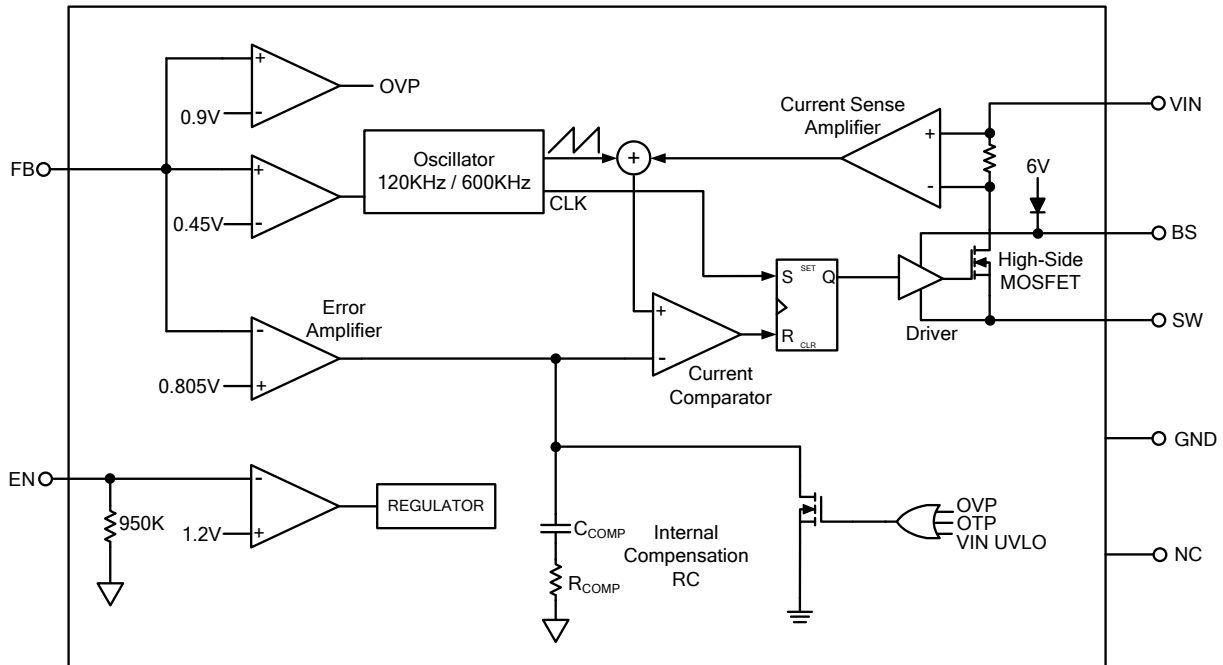

Figure 3. Block Diagram of FR97063

**Absolute Maximum Ratings**

- Supply Voltage V<sub>IN</sub> ----- +25V
- SW Voltage V<sub>SW</sub> ----- -3V to V<sub>IN</sub> +0.3V
- V<sub>BS</sub> ----- V<sub>sw</sub> +6V
- All Other Pins Voltage ----- -0.3V to +6V
- Maximum Junction Temperature (T<sub>J</sub>) ----- +150°C
- Storage Temperature (T<sub>S</sub>) ----- -65°C to +150°C
- Lead Temperature (Soldering, 10sec.) ----- +260°C
- Power Dissipation @T<sub>A</sub>=25°C, (P<sub>D</sub>)
  - SOP-8 ----- 0.63W
- Package Thermal Resistance, (θ<sub>JA</sub>)
  - SOP-8 ----- 160°C/W

Note 1 : Stresses beyond those listed under "Absolute Maximum Ratings" may cause permanent damage to the device.

**Recommended Operating Conditions**

- Input Supply Voltage (V<sub>IN</sub>) ----- +4.5V to +23V
- Output Voltage (V<sub>OUT</sub>) ----- +0.805V to +15V
- Operation Temperature Range ----- -40°C to +85°C

## Electrical Characteristics

( $V_{IN}=12V$ ,  $T_A=25^{\circ}C$ , unless otherwise specified.)

Parameter	Conditions	Min	Typ	Max	Unit
Feedback Voltage	$4.5V \leq V_{IN} \leq 23V$	0.785	0.805	0.825	V
Switch-On Resistance (*)			250		m $\Omega$
Switch Leakage	$V_{EN}=0V$ , $V_{SW}=0V$			10	$\mu A$
Current Limit (*)			2.5		A
Oscillator Frequency	$V_{FB}=0.3V$	480	600	720	KHz
Fold-Back Frequency	$V_{FB}=0V$		120		KHz
Maximum Duty Cycle			85		%
Minimum On-Time (*)			100		ns
Under Voltage Lockout Threshold Rising		4.1	4.4	4.7	V
Under Voltage Lockout Threshold Hysteresis			250		mV
EN Input Low Voltage				0.4	V
EN Input High Voltage		1.2			V
EN Input Current	$V_{EN}=2V$		2.0		$\mu A$
	$V_{EN}=0V$		0.1		
Supply Current (Shutdown)	$V_{EN}=0V$		10		$\mu A$
Supply Current (Quiescent)	$V_{EN}=2V$ , $V_{FB}=1V$		2		mA
Thermal Shutdown (*)			150		$^{\circ}C$

\* Guaranteed by design

## Typical Performance Curves

$V_{IN}=12V$ ,  $V_{OUT}=3.3V$ ,  $C1=10\mu F$ ,  $C2=22\mu F$ ,  $L1=4.7\mu H$ ,  $T_A=+25^\circ C$ , unless otherwise noted.

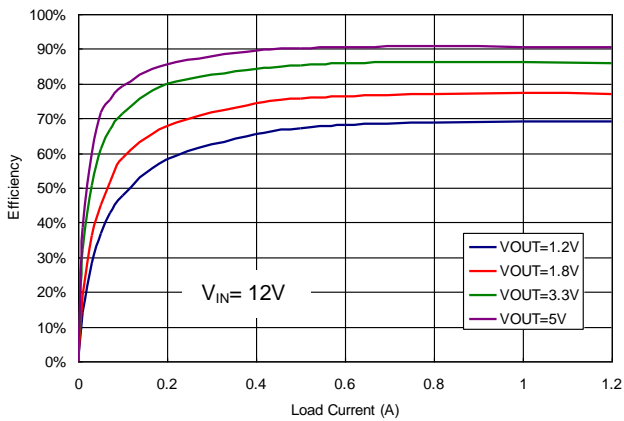

Figure 4. Efficiency vs. Loading

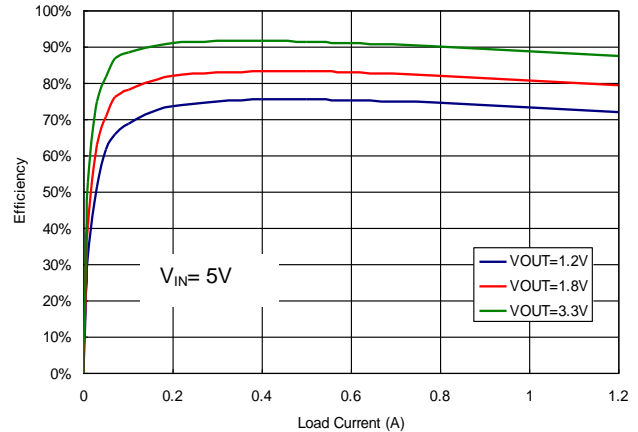

Figure 5. Efficiency vs. Loading

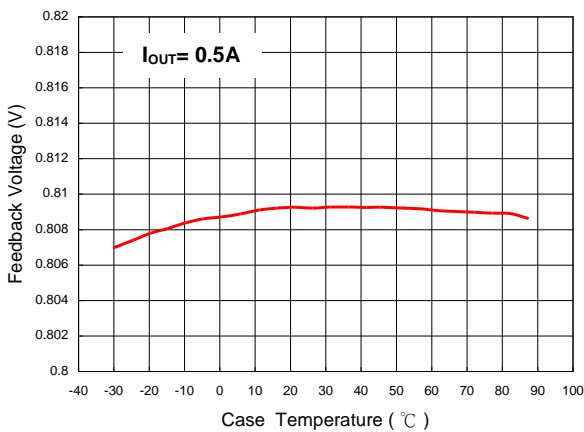

Figure 6. Feedback Voltage vs. Case Temperature

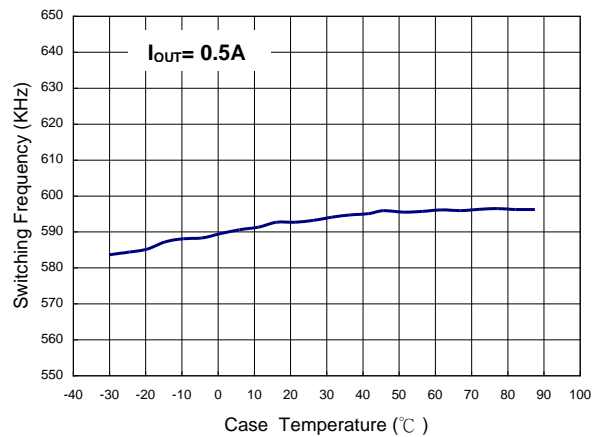

Figure 7. Switching Frequency vs. Case Temperature

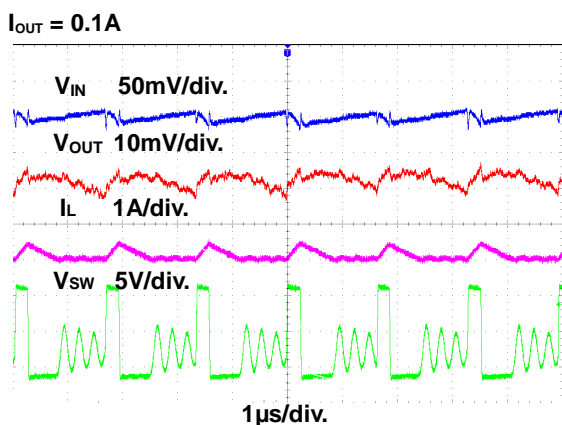

Figure 8. DC Ripple Waveform

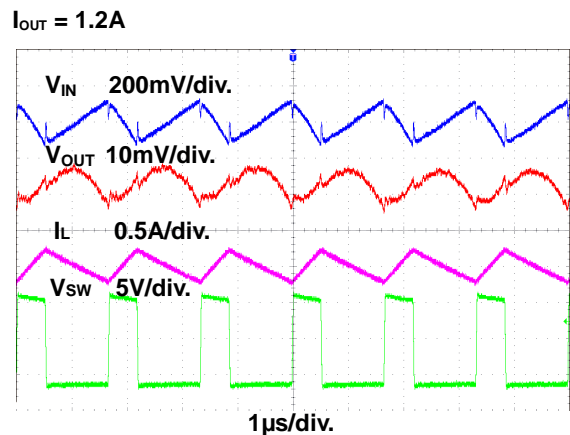

Figure 9. DC Ripple Waveform

**Typical Performance Curves (Continued)**

$V_{IN}=12V$ ,  $V_{OUT}=3.3V$ ,  $C1=10\mu F$ ,  $C2=22\mu F$ ,  $L1=4.7\mu H$ ,  $T_A=+25^{\circ}C$ , unless otherwise noted.

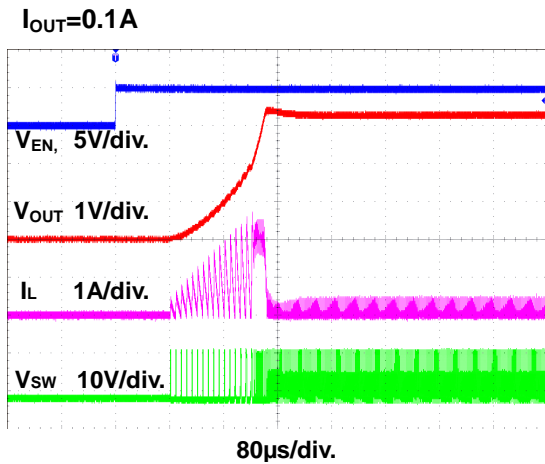

Figure 10. Startup Through Enable Waveform

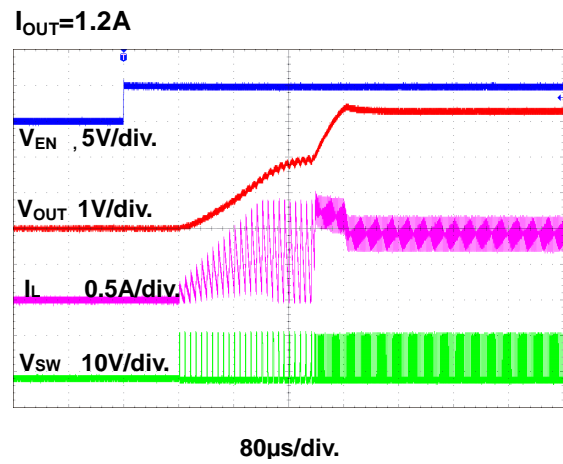

Figure 11. Startup Through Enable Waveform

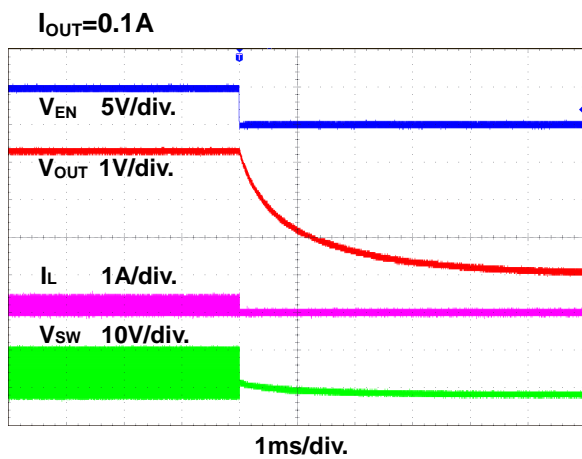

Figure 12. Shutdown Through Enable Waveform

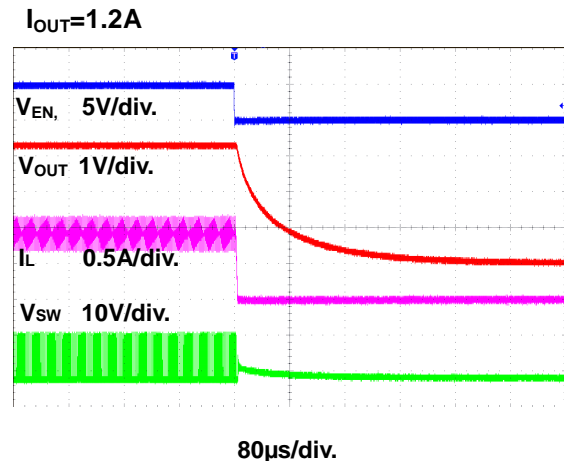

Figure 13. Shutdown Through Enable Waveform

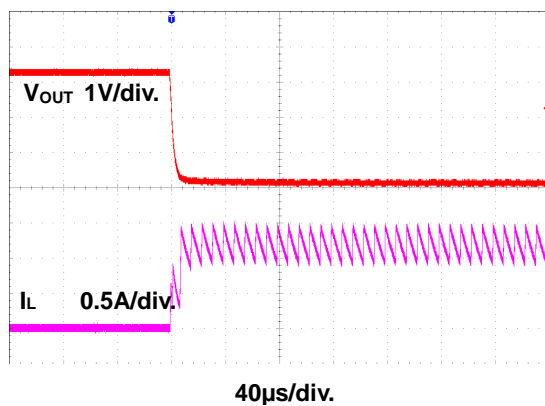

Figure 14. Short Circuit Test Waveform

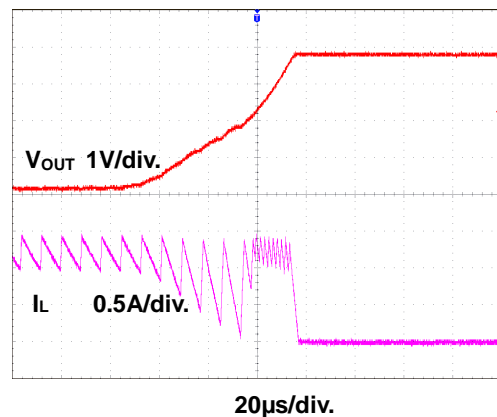

Figure 15. Short Circuit Recovery Waveform

## Typical Performance Curves (Continued)

$V_{IN}=12V$ ,  $V_{OUT}=3.3V$ ,  $C1=10\mu F$ ,  $C2=22\mu F$ ,  $L1=4.7\mu H$ ,  $T_A=+25^\circ C$  unless otherwise noted.

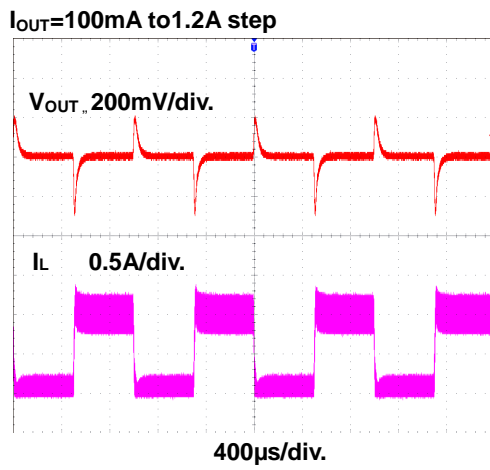
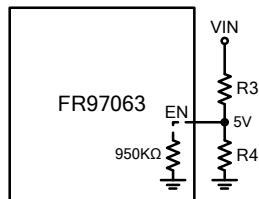

Figure 16. Load Transient Waveform

## Application Information

### Setting EN Automatic Startup Voltage



The external resistor divider is used to set the EN automatic startup voltage:

$$R4 = \frac{V_{EN}}{\left(\frac{V_{IN} - V_{EN}}{R3}\right)}$$

For example,  $V_{IN}=12V$ ,  $R3=100K\Omega$ , thus  $R4$  resistor value is:

$$R4 = \frac{5V}{\left(\frac{12V - 5V}{100K\Omega}\right)} \approx 71.5K\Omega$$

Table 1 shows a list of resistor selection for common input voltages:

**Table 1 -- Resistor Selection for Common Input Voltages**

VIN	R3	R4
5V	100KΩ	NC
12V	100KΩ	71.5KΩ
16V	100KΩ	45.3KΩ

### Setting Output Voltage

The external resistor divider is used to set the output voltage. FR97063 feedback resistors are unconcerned of compensation and provide an easy way to program output voltage. Table 2 shows a list of resistor selection for common output voltages:

$$V_{OUT} = 0.805 \times \left(1 + \frac{R1}{R2}\right) V$$

**Table 2 -- Resistor Selection for Common Output Voltages**

V <sub>OUT</sub>	R1	R2
5V	43KΩ	8.2KΩ
3.3V	30.9KΩ	10KΩ
2.5V	21KΩ	10KΩ
1.8V	12.4KΩ	10KΩ

### Selecting the Inductor

A 4.7μH inductor with a DC current rating of at least 25% percent higher than the maximum load current is recommended for most applications. For the highest efficiency, the inductor's DC resistance should be less than 200mΩ. For most designs, the required inductance value can be derived from the following equation:

$$\Delta I = 0.3 \times I_{L(MAX)}$$

$$L \geq (V_{IN} - V_{OUT}) \times \left(\frac{V_{OUT}}{F_{SW} \times \Delta I \times V_{IN}}\right)$$

Where  $\Delta I$  is the inductor ripple current.

Choose the inductor ripple current to be 30% of the maximum load current. The maximum inductor peak current is calculated from:

$$I_{L(MAX)} = I_{LOAD} + \frac{\Delta I_L}{2}$$

Under light load conditions below 100mA, a larger inductance is recommended for improving efficiency.

### Selecting the Input Capacitor

The input capacitor reduces the surge current drawn from the input supply and the switching noise from the device. The input capacitor impedance at the switching frequency should be less than the input source impedance to prevent high frequency switching current from passing through the input. Ceramic capacitors with X5R or X7R dielectrics are highly recommended because of their low ESR and small temperature coefficients. For most applications, a 10μF capacitor is sufficient.

## Application Information (Continued)

### Selecting the Output Capacitor

The output capacitor keeps the output voltage ripple small and a 22 $\mu$ F ceramic capacitor with X5R or X7R dielectrics is recommended for its low ESR characteristics.

### External Bootstrap Diode

An external bootstrap diode is recommended if the input voltage is less than 5V or if there is a 5V system rail available. This diode helps improving the efficiency. Low cost diodes, such as 1N4148, are suitable for this application.

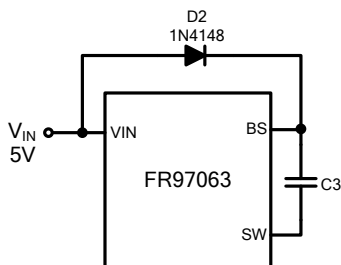

### Rectifier Diode

Use a Schottky diode as the rectifier to conduct current when the high-side power MOSFET is off. The Schottky diode must have current rating higher than the maximum output current and the reverse voltage rating higher than the maximum input voltage.

### PCB Layout Recommendation

The device's performance and stability are dramatically affected by PCB layout. It is recommended to follow these general guidelines shown as below:

1. Place the input capacitors and output capacitors as close to the device as possible. The traces which connect to these capacitors should be as short and wide as possible to minimize parasitic inductance and resistance.
2. Place VIN bypass capacitors close to the VIN pin.
3. Place feedback resistors close to the FB pin.
4. Keep the sensitive signal FB away from the switching signal SW.

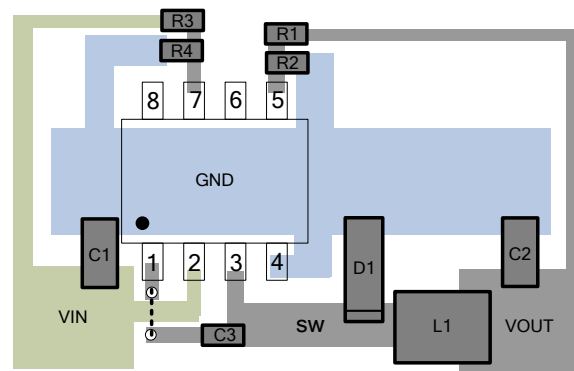
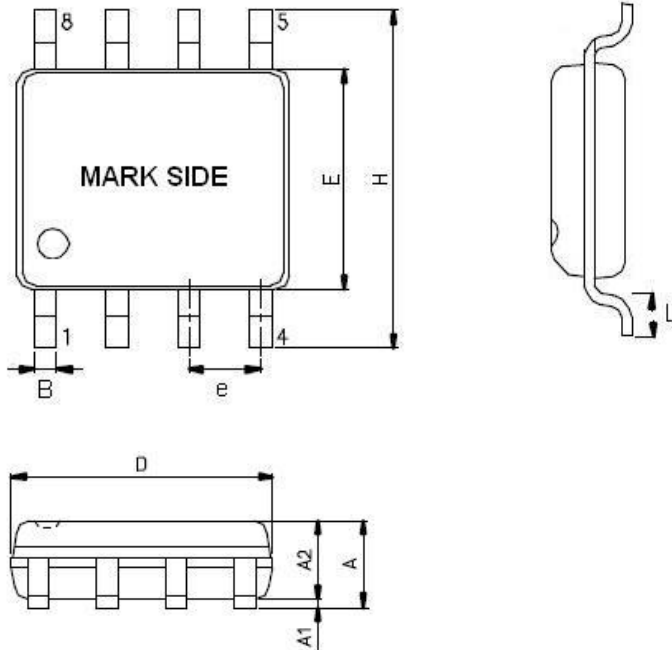

Figure 17. Recommended Layout Diagram

**Outline Information**

SOP-8 Package (Unit: mm)



SYMBOLS UNIT	DIMENSION IN MILLIMETER	
	MIN	MAX
A	1.35	1.75
A1	0.10	0.25
A2	1.25	1.50
B	0.31	0.51
D	4.80	5.00
E	3.80	4.00
e	1.20	1.34
H	5.80	6.20
L	0.40	1.27

Note : Followed From JEDEC MO-012-E.

**Carrier Dimensions**

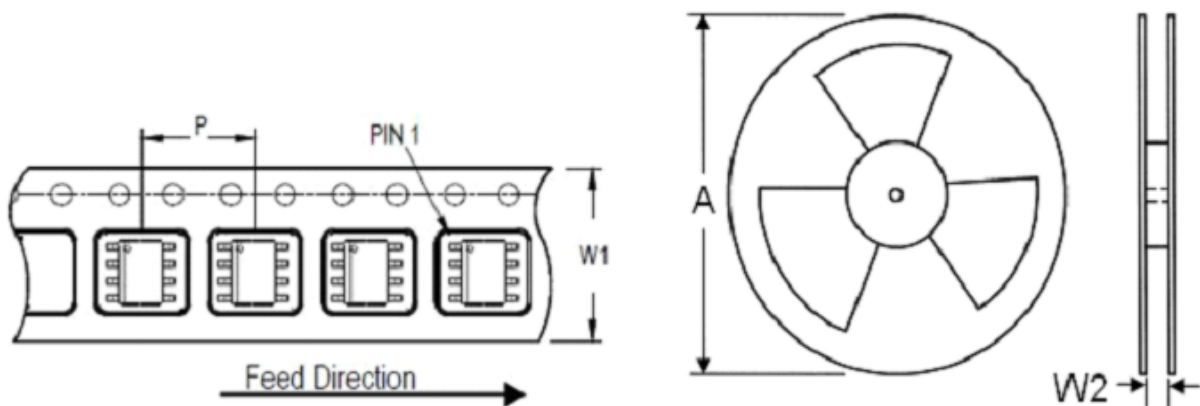

Tape Size (W1) mm	Pocket Pitch (P) mm	Reel Size (A)		Reel Width (W2) mm	Empty Cavity Length mm	Units per Reel
		in	mm			
12	8	13	330	12.4	400~1000	2,500

**Life Support Policy**

Fitipower's products are not authorized for use as critical components in life support devices or other medical systems.